

DIRECTIONAL CONTROL VALVES 1ST(B)4432**GENERAL DESCRIPTION**

Figure 1 1ST(B)4432 General Arrangement







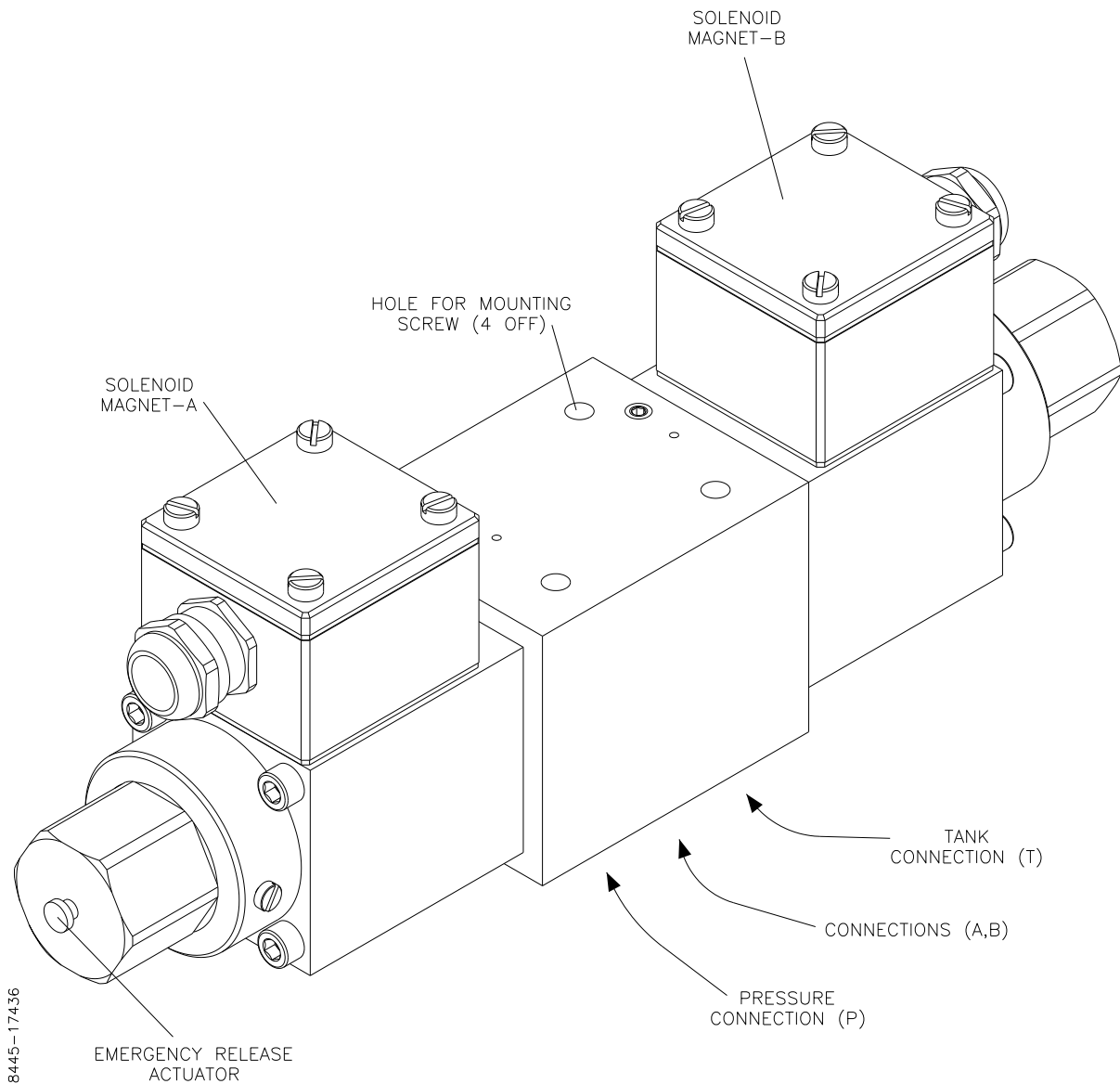

The Directional Control Valves 1ST(B)4432**** are a solenoid operated 4-ways seawater resistant valves for distribution and stopping of flow in hydraulic systems. The valves have the following characteristics:

- Delivered for gasket mounting to a sub plate according to ISO standard 4401, size 05.
- Electrically controlled (on/off) – 24 VDC or 220 VAC.
- Delivered with emergency actuating button.
- Flow capacity 45 l/min.

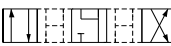
For more details about types and options, please refer to section 'Modular Code'.

Directional Control Valves 1ST(B)4432

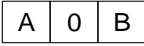
MODULAR CODE

Options	Remarks	Design Code	Fill in
Mounting			1ST
SUB Plate	ISO 4401	B	B
Type			
4-ways	No options	4	4
Pressure			
350 bar	No options	4	4
Operation			
Solenoid		3	3
Size			
NG10 (ISO-05)	45 l/min	2	2
Spool Type			
		01	
		02	
		06	
		0J	
		2C	
Spring / Detents Positions			
Spring centred		1	1
Solenoid Type			
Single	Solenoid B side	E	
Double	Solenoid A and B side	D	
Voltage			
24 V DC		3AD	
220 V AC 50 Hz		30D	

Other spool symbols and voltages on request.

In example a 1ST(B)4432 valve with spool type 02, double solenoid and 24 VDC will have modular code: **1STB4432021D.3AD**

Directional Control Valves 1ST(B)4432

DIMENSIONS

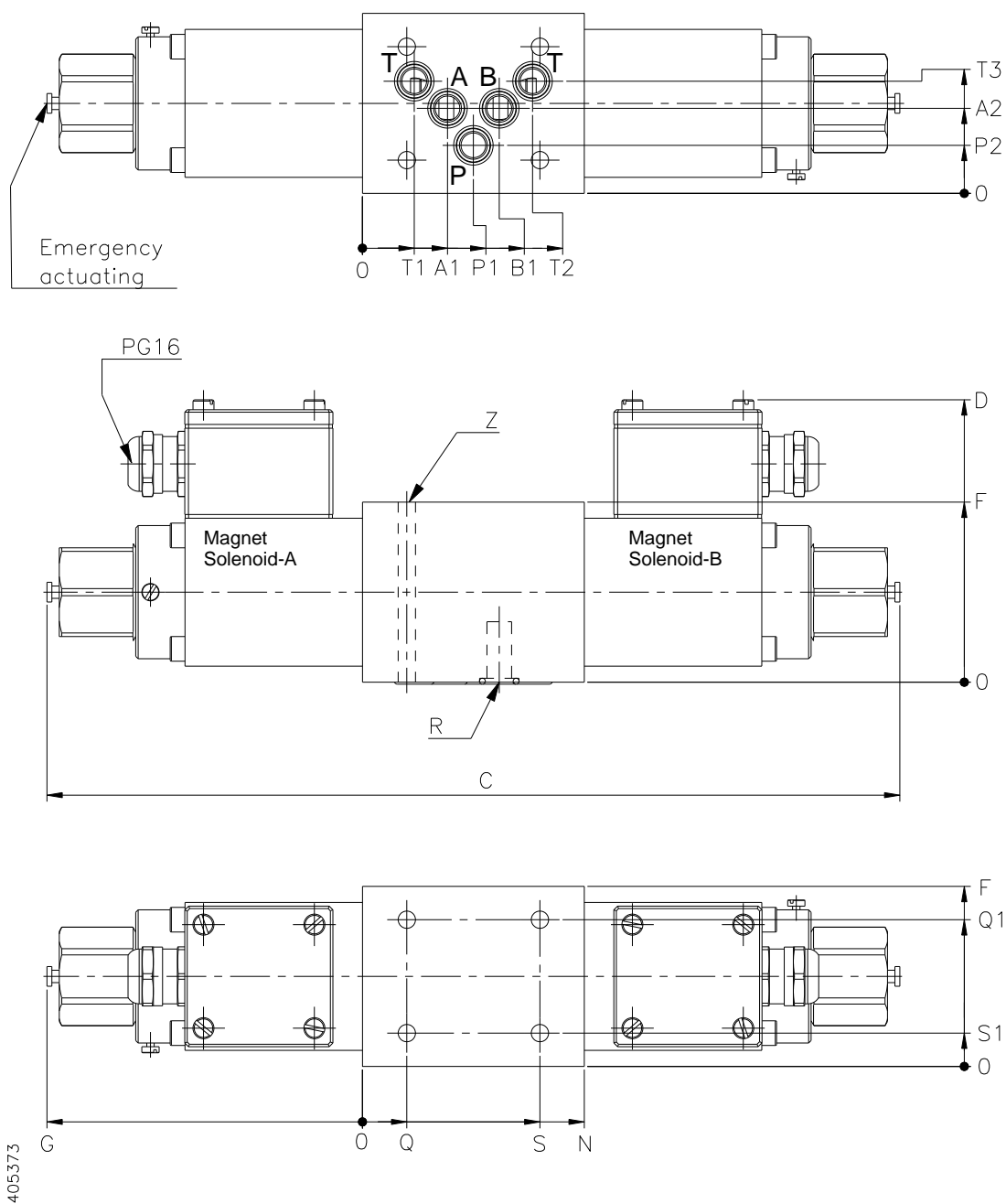
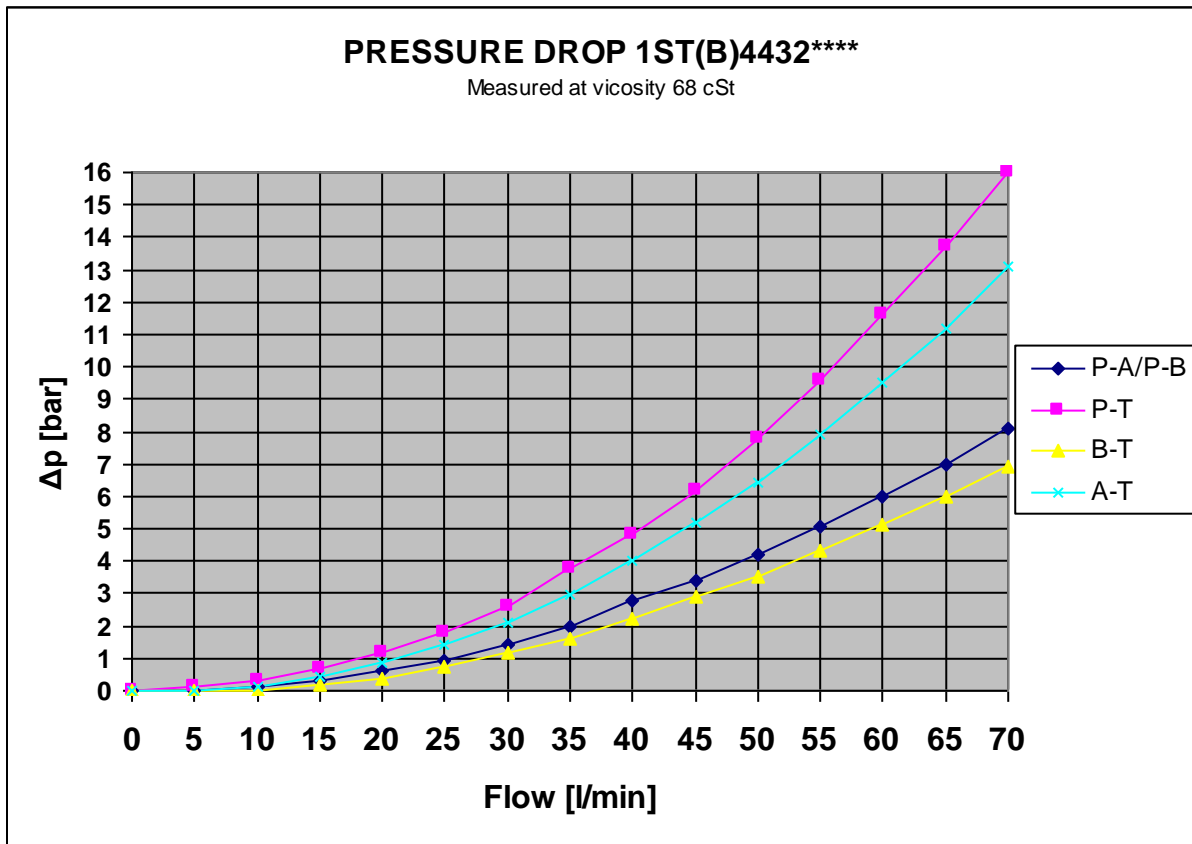

Figure 2 1STB4432 Dimensions

Size [mm]	C	D	F	G	N	A1	A2	B1	P1	P2
10 D	354	114.5	73	132	90	34.5	34.5	55.5	45	19.5
10 E	238	114.5	73	132	90	34.5	34.5	55.5	45	19.5
	T1	T2	T3	Z		Q	Q1	S	S1	
10 D	21	69	45.5	6.5		18	59.5	72	13.5	
10 E	21	69	45.5	6.5		18	59.5	72	13.5	

Directional Control Valves 1ST(B)4432

PRESSURE DROP



TECHNICAL DATA

Description	Symbol	Data
Max. operating pressure in port P, A, B	P_{nom}	350 bar
Max. pressure in port T	T_{max}	315 bar
Test Pressure	P_{max}	420 bar
Solenoid protection, See Note 1		IP 65
Solenoid Power 24VDC Solenoid Power 220VAC	p	34 W 34 W
Solenoid Current 24VDC Solenoid Current 220VAC	I	1.4 Amp 0.17 Amp
Resistance R, 24VDC Resistance R, 220VAC	Ω	18 Ohm 1900 Ohm
Hydraulic fluid		Mineral oils for hydraulic system
Viscosity range:	ν	10 to 350 mm ² /s (cST)
Viscosity index:	VI	> 120
Filtration, recommended filter with $\beta_{20} \geq 100$		Class 9 according to NAS 1638, 18/15 according to ISO 4406
Fluid temperature range:	T	-20°C to + 70°C
Ambient temperature range	T	-20°C to + 50°C
Standard Body Material		EN-GJS-400-15 (GGG 40)
Standard O-rings		Nitrile shore 70

Note 1: Pressure sealed sea water protected solenoid.

Flow and Weight:

Type	Max. Flow	Weight
D	45 l/min	8.9 kg
E	45 l/min	7.3 kg

Interfaces:

Description	Data
Electrical Connection: Cable glands PG 16	Cable dim. Ø10-Ø14.
Screws	Tightening Torque [Nm]
4 off M 6 x 90 - DIN 912	15.5
O-rings	Size [mm]
5 off	11.3 x 2.4

Directional Control Valves 1ST(B)4432

INSTALLATION

The Direction Control Valves 1STB4432 are installed with 4 off screws to a SUB plate (ISO 4401, size 5). Please refer to section 'Interfaces' for details about electrical connection, screws and o-rings.

OPERATION

When energize the solenoid, a push pin moves the spool to the requested position – on/off.

Emergency function: The valve can be switched manual by pushing a rubber cap at the solenoid. To release the valve first dismount the protective hexagon nut.

MAINTENANCE

Check the valve for proper function. Visually check the valve and if required, paint unpainted (damaged) areas.

STORAGE

If storage longer than 6 months is expected, the valve must be kept in a dry room, free from dust and protected against sudden large temperature variations. For storage longer than 12 months, the valve must be filled with inhibition oil. Before use check all visible seals and flush with clean oil.

MARKING

Inlets and outlets are marked, refer to figure in section 'General Description'.