

DIRECTIONAL CONTROL VALVES 1STB44*(2)(4)(5)

GENERAL DESCRIPTION

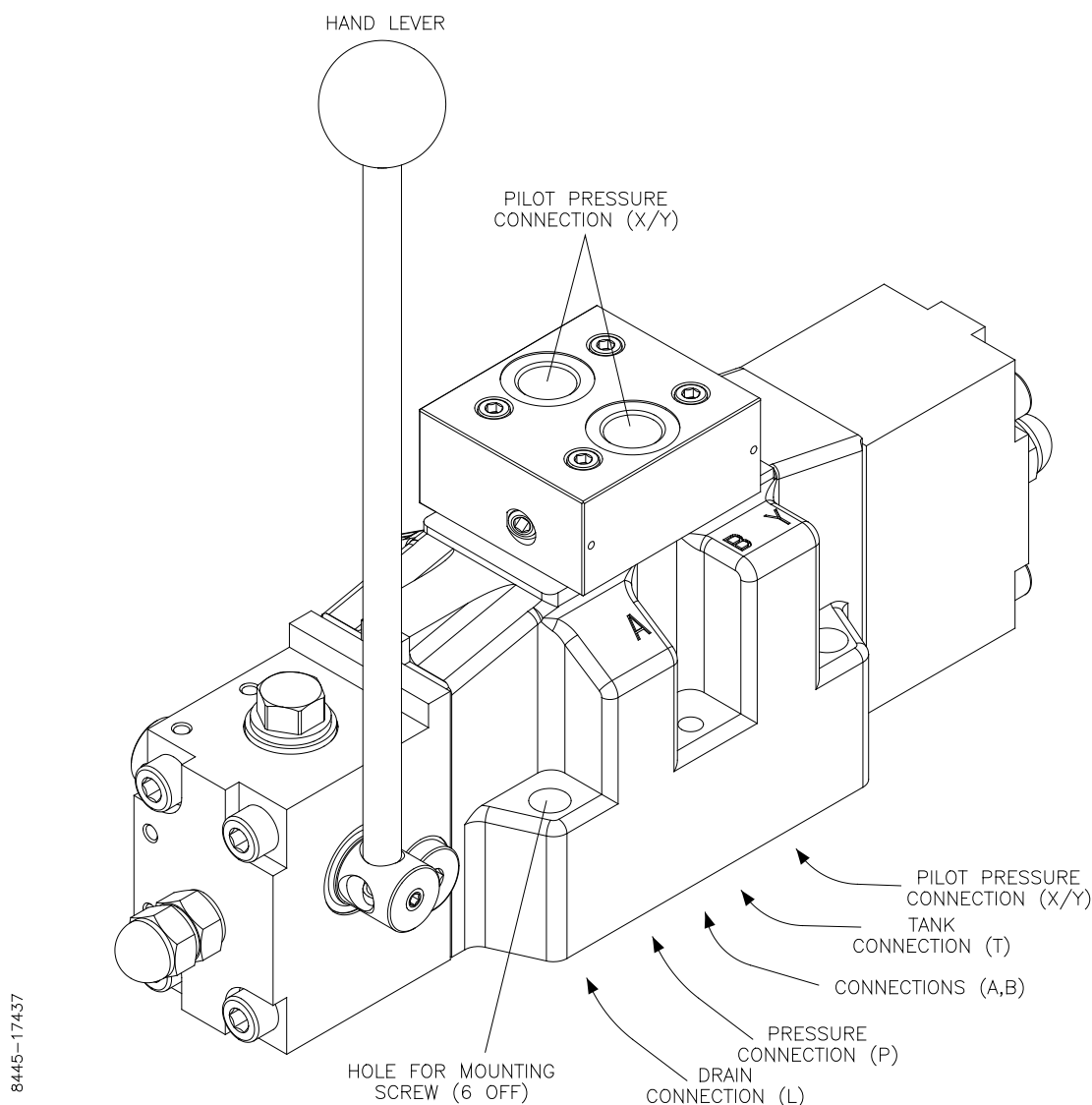

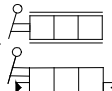



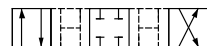



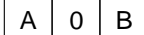
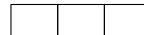

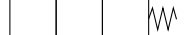

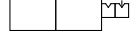

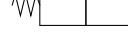
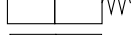
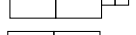

Figure 1 1STB4474 General Arrangement

The Directional Control Valves 1STB44*(2)(4)(5) (NG10-16-25) are 4-ways seawater resistant valves for smooth distribution and stopping of flow in hydraulic systems. The valves have the following characteristics:

- Delivered for gasket mounting to a sub plate according to ISO standard 4401.
- Proportional controlled manually with a hand lever, or proportional remotely controlled by hydraulic pilot pressure.
- Delivered with flow capacity up to 500 l/min.
- Six standard spools with throttling grooves for smooth start and stop are available.
- A number of possibilities for spool positioning, spring or detents.
- Most of the hand lever operated directional control valves can be equipped with the Brake Release Valve BA3/BA4. For description of the Brake Release Valves, please refer to separate manual.

For more details about types and options, please refer to section 'Modular Code'.

Directional Control Valves 1STB44*(2)(4)(5)

MODULAR CODE SYSTEM		Remarks	Design Code	Fill in
Mounting				1ST
SUB Plate		ISO 4401	B	B
Type				
4-ways		No options	4	4
Pressure				
350 bar		No options	4	4
Operation				
Manual			1	
Manual/ Proportional Remote			7	
Size				
NG10 – ISO 05		100 l/min	2	
NG16 – ISO 07		300 l/min	4	
NG25 – ISO 08		500 l/min	5	
Spool Type				
			01	
			02	
			03	
			06	
			07	
			2C	
Spring / Detents Positions				
No spring			0	
Spring centred			1	
Spring offset to A			2	
Spring offset to B			3	
Detents in all positions			4	
Detents in position B and 0, A blocked			7	
Spring offset to B, A blocked			8	
Spring centred, A blocked			9	
Spring centred, B blocked			A	
Detents in positions A and 0, B blocked			B	
Spring offset to A, B blocked			C	
Modification				
NG 10		No options	C	
NG 16		No options	A	
NG 25		No options	A	
NG 25-A			A	

Directional Control Valves 1STB44*(2)(4)(5)

In example a 1STB44* valve, manually controlled, 300 l/min flow, spool type 02 and spring centred will have modular code: **1STB4414021**.

DIMENSIONS

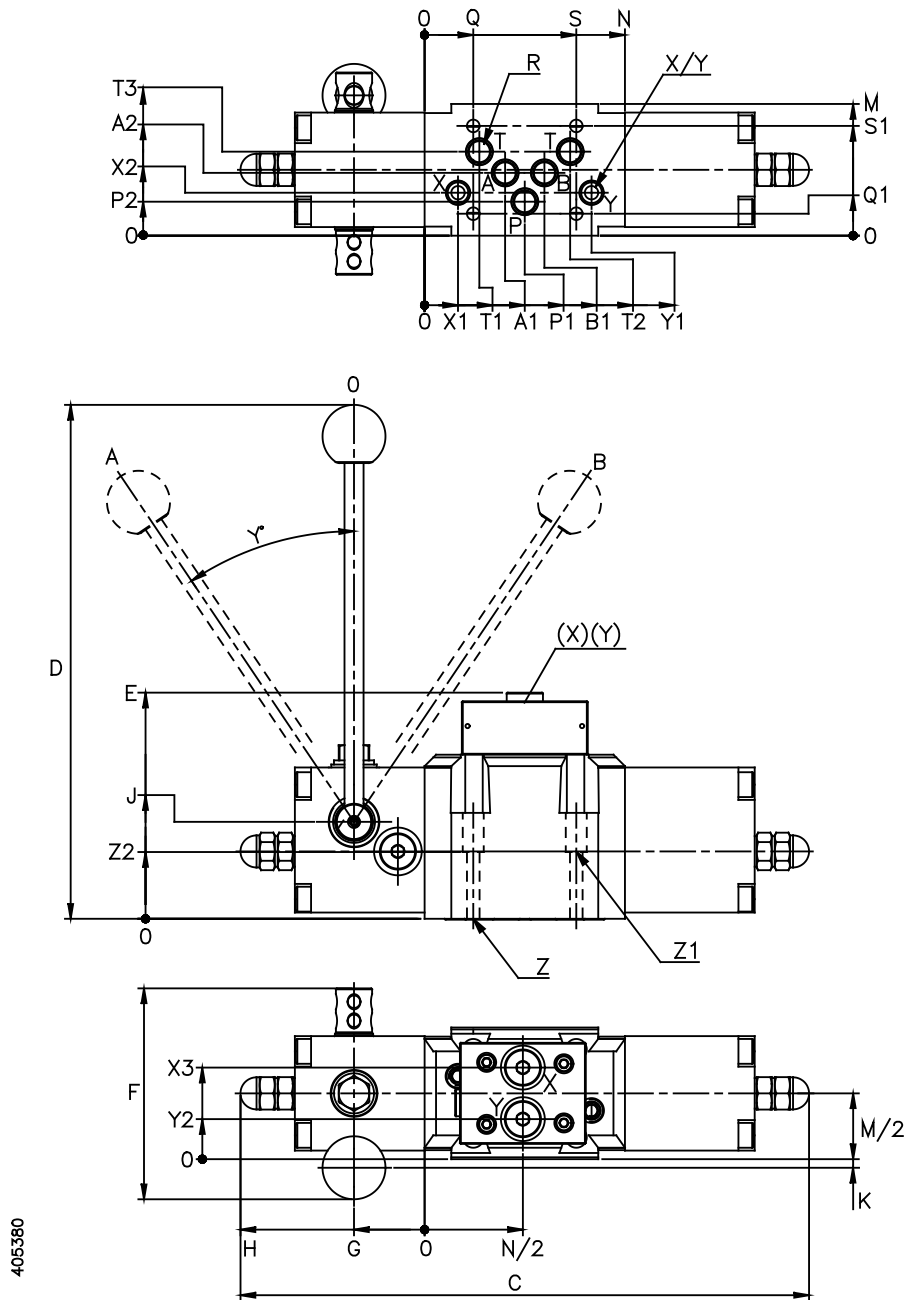

Figure 2 1STB4472 Dimensions (NG10)

Directional Control Valves 1STB44*(2)(4)(5)

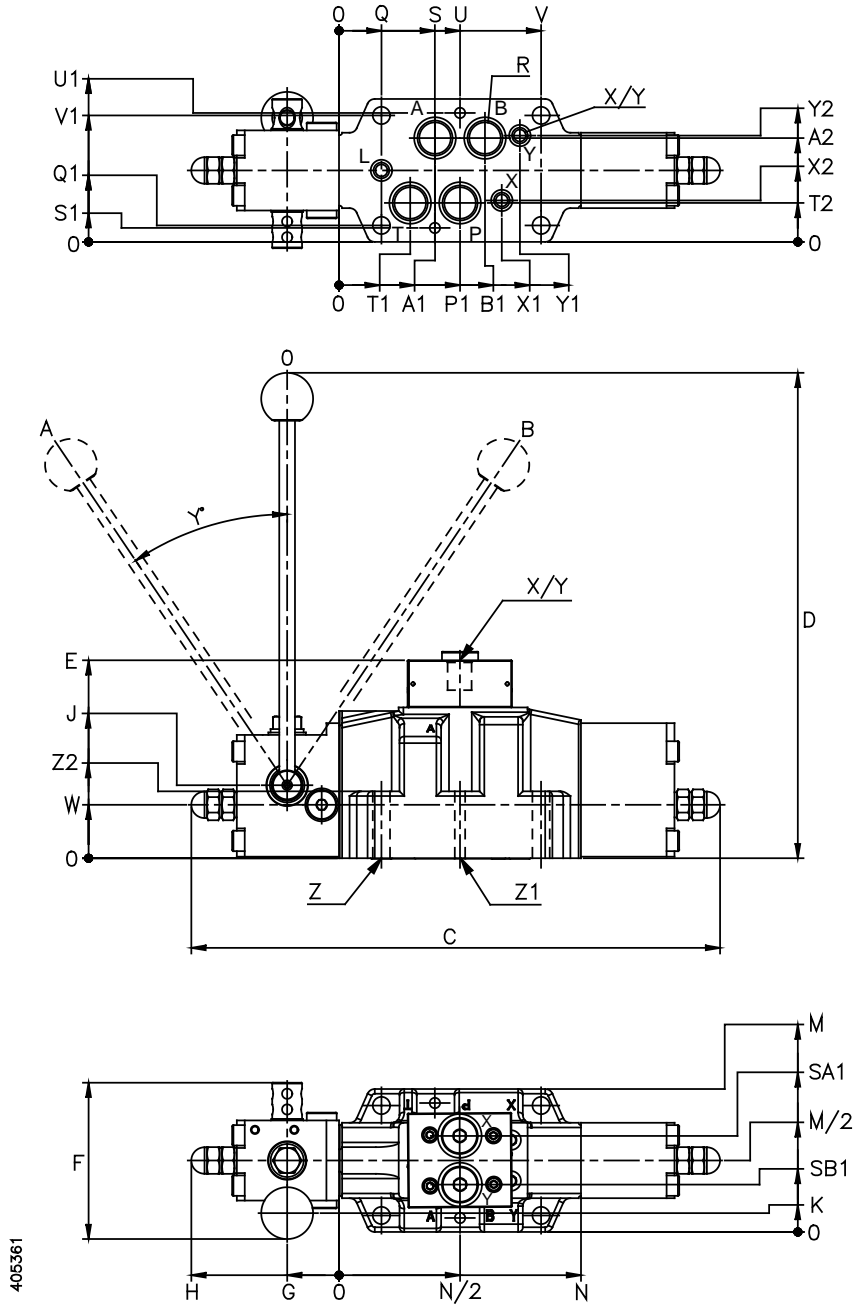

Figure 3 1STB4474 Dimensions (NG16)

Directional Control Valves 1STB44*(2)(4)(5)

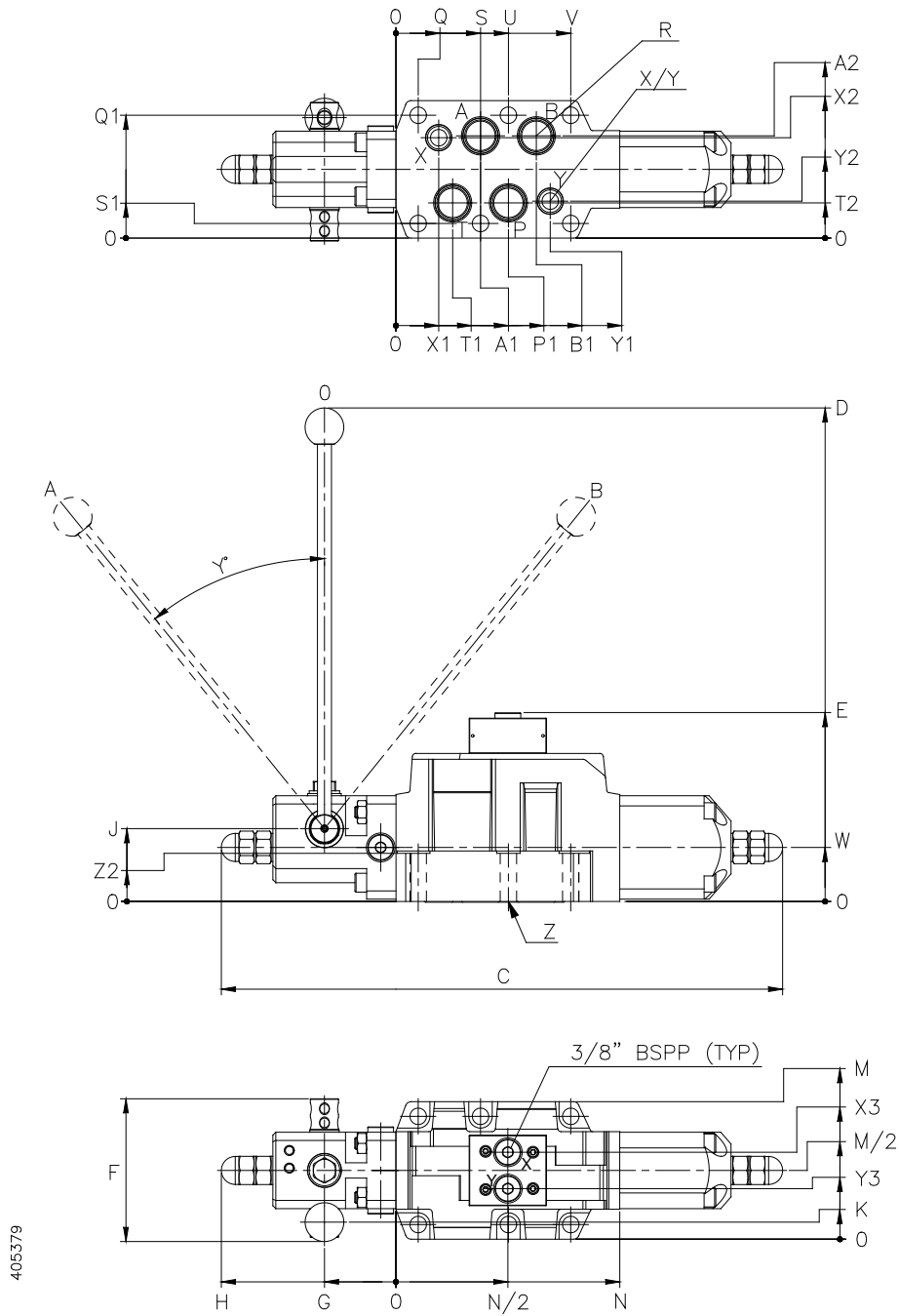

Figure 4 1STB4475 Dimensions (NG25)

405379

Directional Control Valves 1STB44*(2)(4)(5)

According to ISO 4401-08-07-0-94

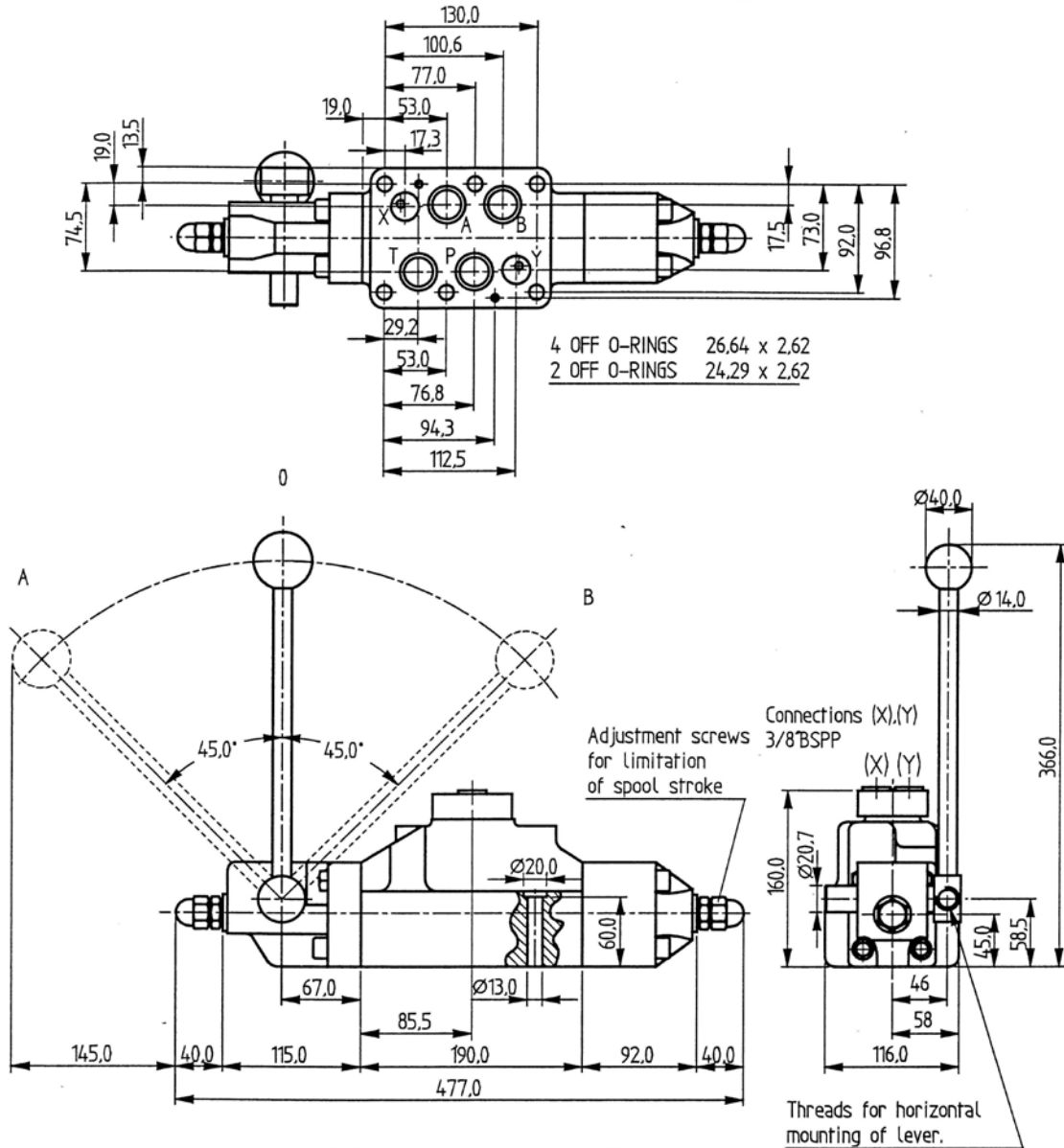
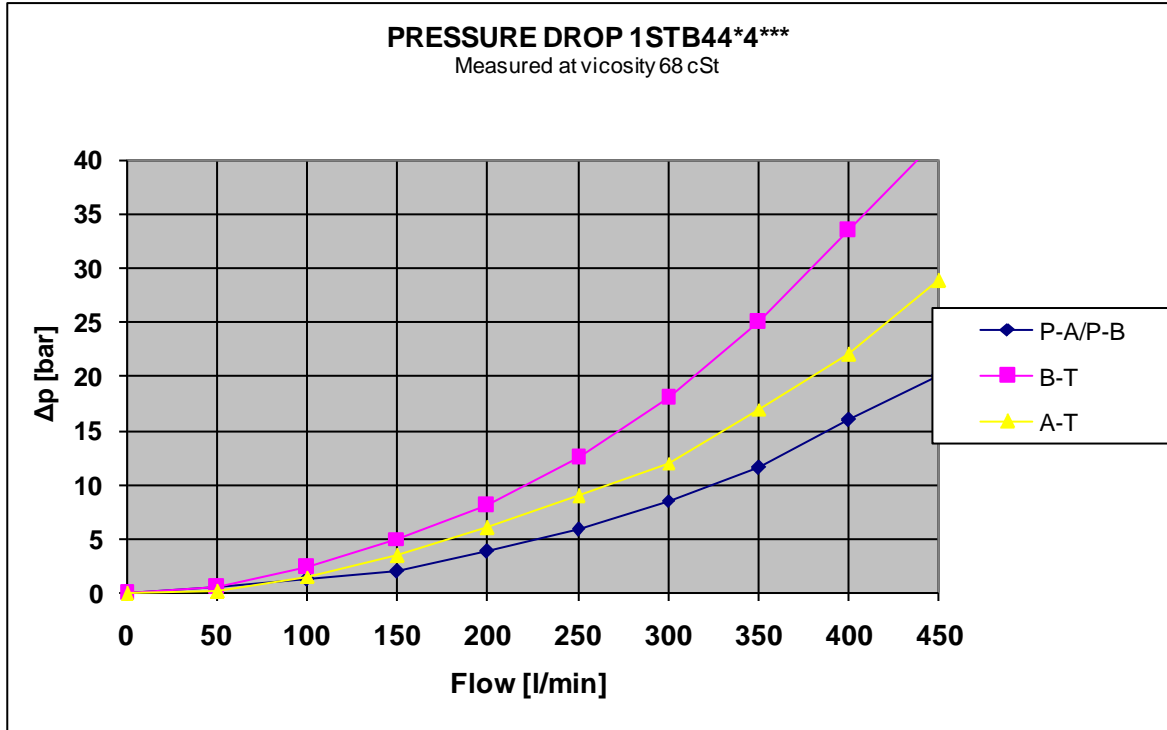
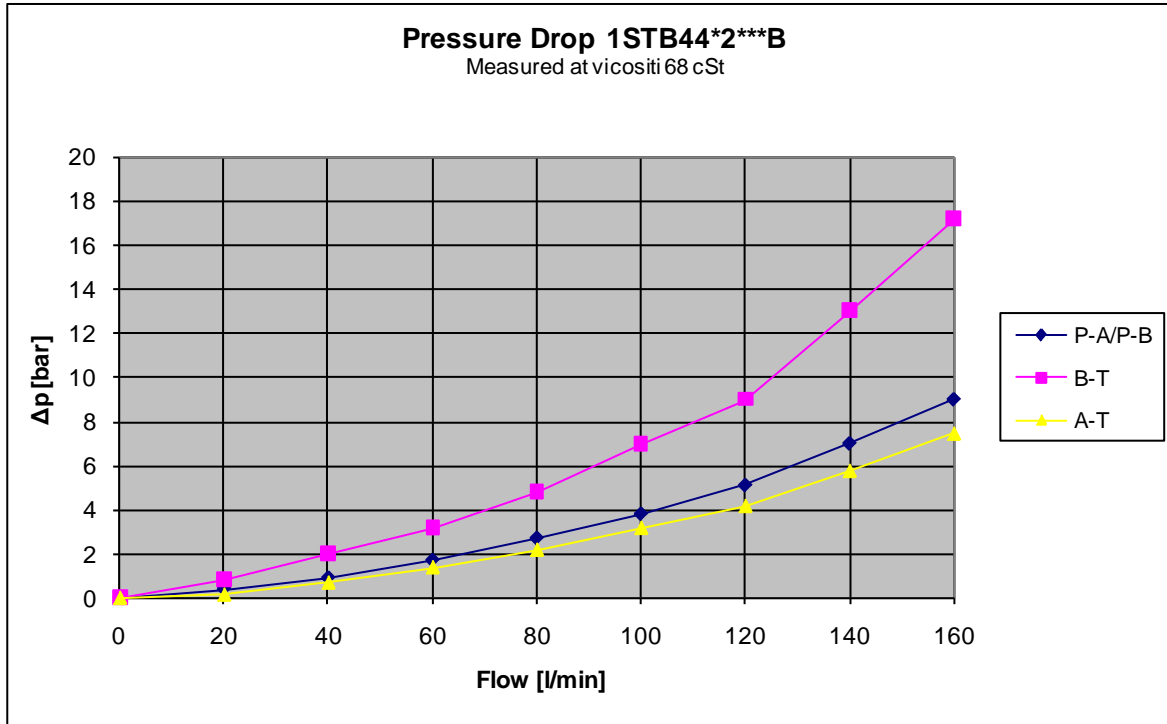

Figure 4A 1STB4475*A Dimensions (NG25)

Directional Control Valves 1STB44*(2)(4)(5)

PRESSURE DROP



Directional Control Valves 1STB44*(2)(4)(5)

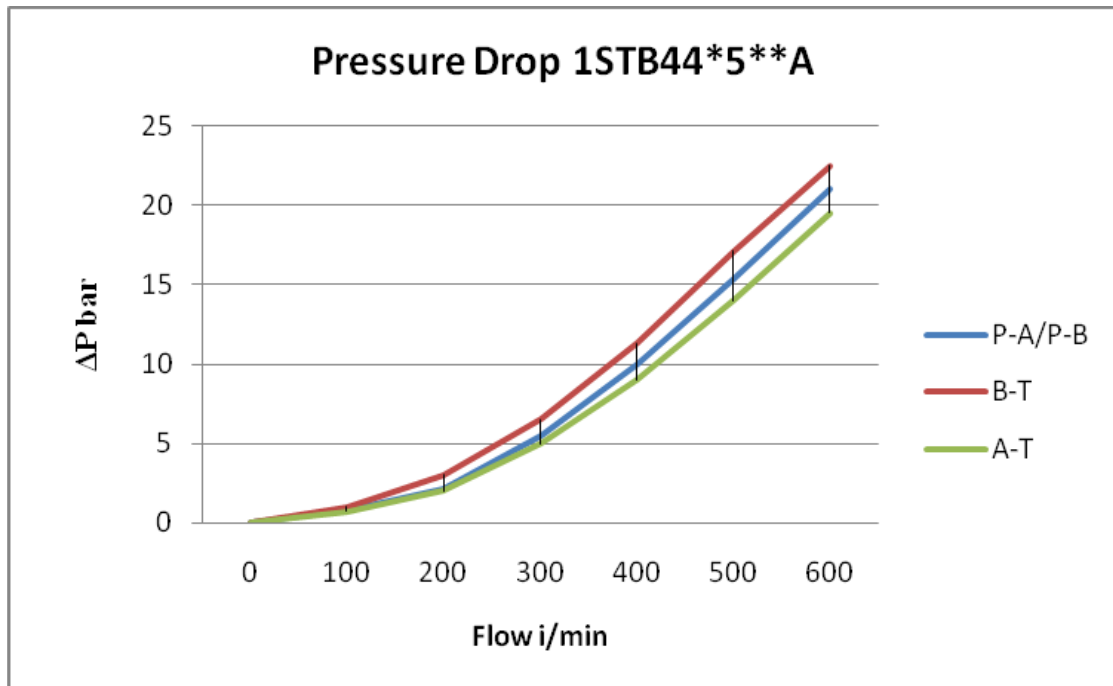
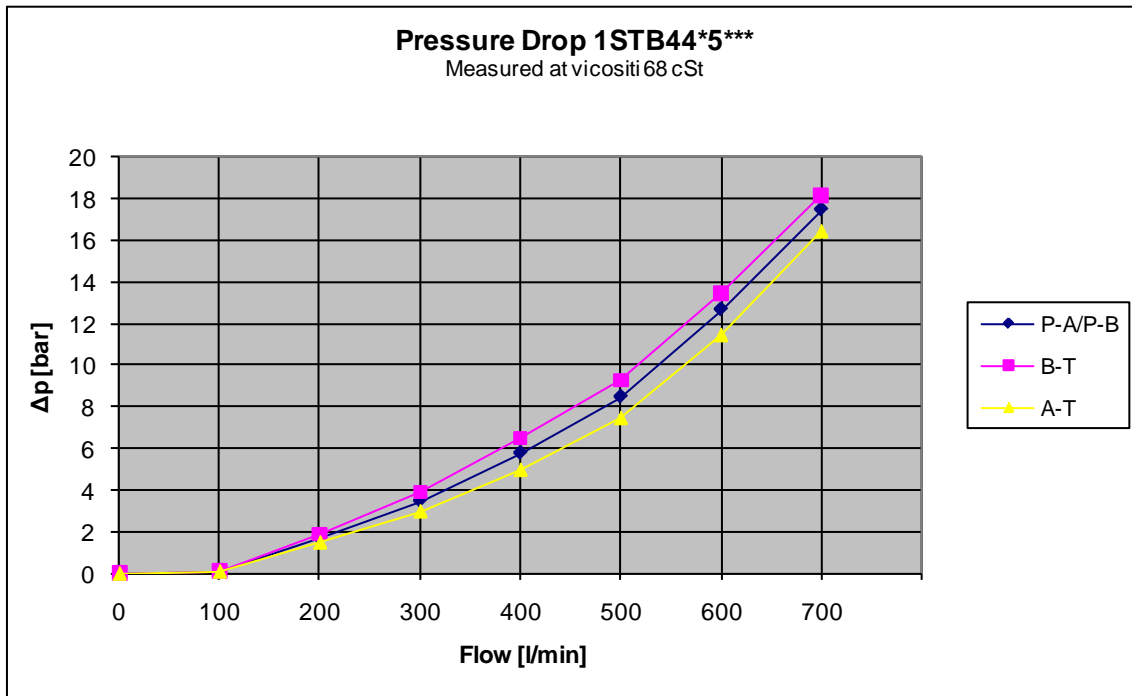

Directional Control Valves 1STB44*(2)(4)(5)

TECHNICAL DATA

Description	Symbol	Data
Max. operating pressure in port P, A, B	P_{max}	350 bar
Max. pressure in port T	T_{max}	50 bar
Max. pressure in port T, when use of separate Y	T_{max}	250 bar
Directional valve pilot pressure (with manual override)	P	5-20
Test Pressure		420 bar
Hydraulic fluid		Mineral oils for hydraulic system
Viscosity range:	ν	10 to 350 mm ² /s (cST)
Viscosity index:	VI	> 120
Filtration, recommended filter with $\beta_{20} \geq 100$		Class 9 according to NAS 1638, 18/15 according to ISO 4406
Fluid temperature range:	T	-20°C to + 70°C
Ambient temperature range	T	-20°C to + 50°C
Standard Body Material		EN-GJS-400-15 (GGG 40)
Standard O-rings		Nitrile shore 70

Flow and Weights:

Size	Max. Flow	Weight
10	100 l/min	6.7 kg
16	300 l/min	10 kg
25	500 l/min	17 kg

Directional Control Valves 1STB44*(2)(4)(5)

Interfaces:

Size	Description	Data
	<i>Screws</i>	<i>Tightening Torque [Nm]</i>
10	4 off M 6 – DIN 912-10.9	15.5
16	4 off M 10 – DIN 912-10.9 2 off M 6 – DIN 912-10.9	74.0 15.5
25	6 off M 12 – DIN 912-10.9	128.0
	<i>O-rings</i>	<i>Size [mm]</i>
10	5 off 2 off	12.0 x 2.0 10.82 x 1.78
16	4 off 2 off	22.3 x 2.4 14.0 x 1.78
25	4 off 2 off	27,0 x 3.0 19.2 x 3.0
25-A	4 off 2 off	26,64 x 2.62 24.29 x 2.62

Directional Control Valves 1STB44*(2)(4)(5)

INSTALLATION

The Directional Control Valves 1 STB44*(2)(4)(5) are installed with 4 or 6 screws to a SUB plate (ISO 4401). Please refer to 'Interfaces', for details about screws and o-rings.

OPERATION

Manual

Proportional manual control is performed by the hand lever. If the valve is delivered with centring spring the spool will return to neutral position after operating the hand lever. If detents the spool will remain in the position set by hand lever.

Proportional Remote

In the remote controlled valves, an external proportional pilot pressure moves the spool to the requested position.

The remote controlled valves are equipped with a hand lever for override of the pilot pressure. The hand lever is mechanically connected to the spool.

MAINTENANCE

Check the valve for proper function. Visually check the valve and if required, paint unpainted (damaged) areas.

CAUTION: Do not paint the hand lever shaft seal.

STORAGE

If storage longer than 6 months is expected, the valve must be kept in a dry room, free from dust and protected against sudden large temperature variations. For storage longer than 12 months, the valve must be filled with inhibition oil. Before use check all visible seals and flush with clean oil.

MARKING

Inlets and outlets are marked, refer to figure in section 'General Description'.