

PRESSURE TRANSMITTER VALVE 1FGB

GENERAL DESCRIPTION

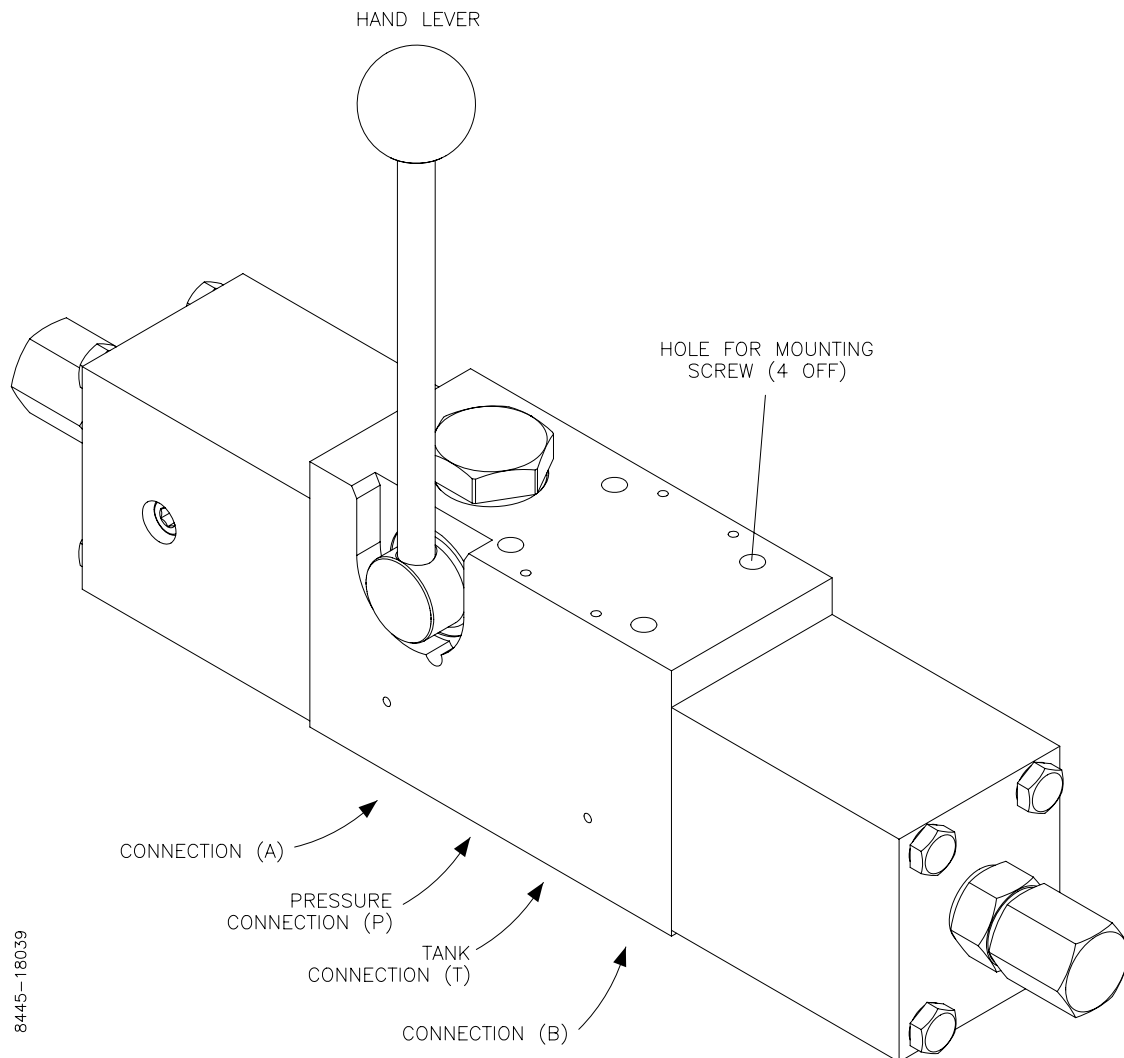

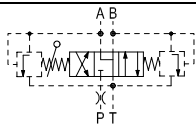
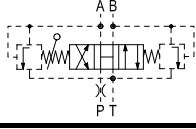

Figure 1 1FGB General Arrangement

The Pressure Transmitter Valve (1 FGB) is a seawater resistant valve intended for proportional, hydraulically remote control of directional valves, positioning cylinders etc. The valve has the following characteristics:

- Manually operated by hand lever
- Delivered for gasket mounting to a sub plate according to ISO 03/Cetop 3
- Several adjustable pressure ranges are available.
- Designed for 350 bar in port P.

For more details about types and options, please refer to section 'Modular Code'.

MODULAR CODE

Options	Remarks	Design Code	Fill in
Pressure transmitter			1FG
Mounting			
ISO 4401-03		B	B
Type			
4-ways	No option	4	4
Pressure			
350 bar		4	4
Operation			
Manual	No option	1	1
Size			
06 mm	No option	1	1
Spool type			
	Standard	1K	
		1L	
Spring return			
Spring centred		1	1
Modification			
	No option	B	B
Pressure ranges (To be selected both for A and B port)			
8 – 35 bar		01	
2 – 15 bar		02	
2 – 85 bar		03	
10 – 50 bar	Standard	05	
5 – 20 bar	Standard (6MB, 7MB)	07	
8 – 45 bar		08	
8 – 25 bar		11	
10 – 30 bar		12	
25-190 bar		15	

In example a 1FGB valve, spool type 1K, with pressure range in port B to be 2 - 15 bar, and pressure range in port A to be 2-85 bar, will have modular code: **1FGB44111K1B-02/03**

Circuit diagram 1FGB44111K1B-*/**

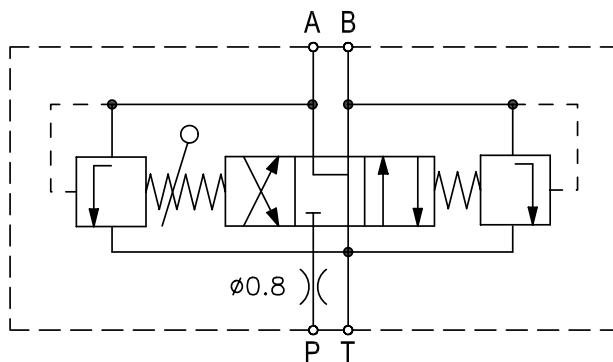

NOTES:

Avoid fluctuation in pressure port P, to achieve best result of the proportional control.
 Pressure in port T is directly additional to valve setting.

An orifice diameter $\varnothing 0.8$ mm is mounted in port P.

DIMENSIONS

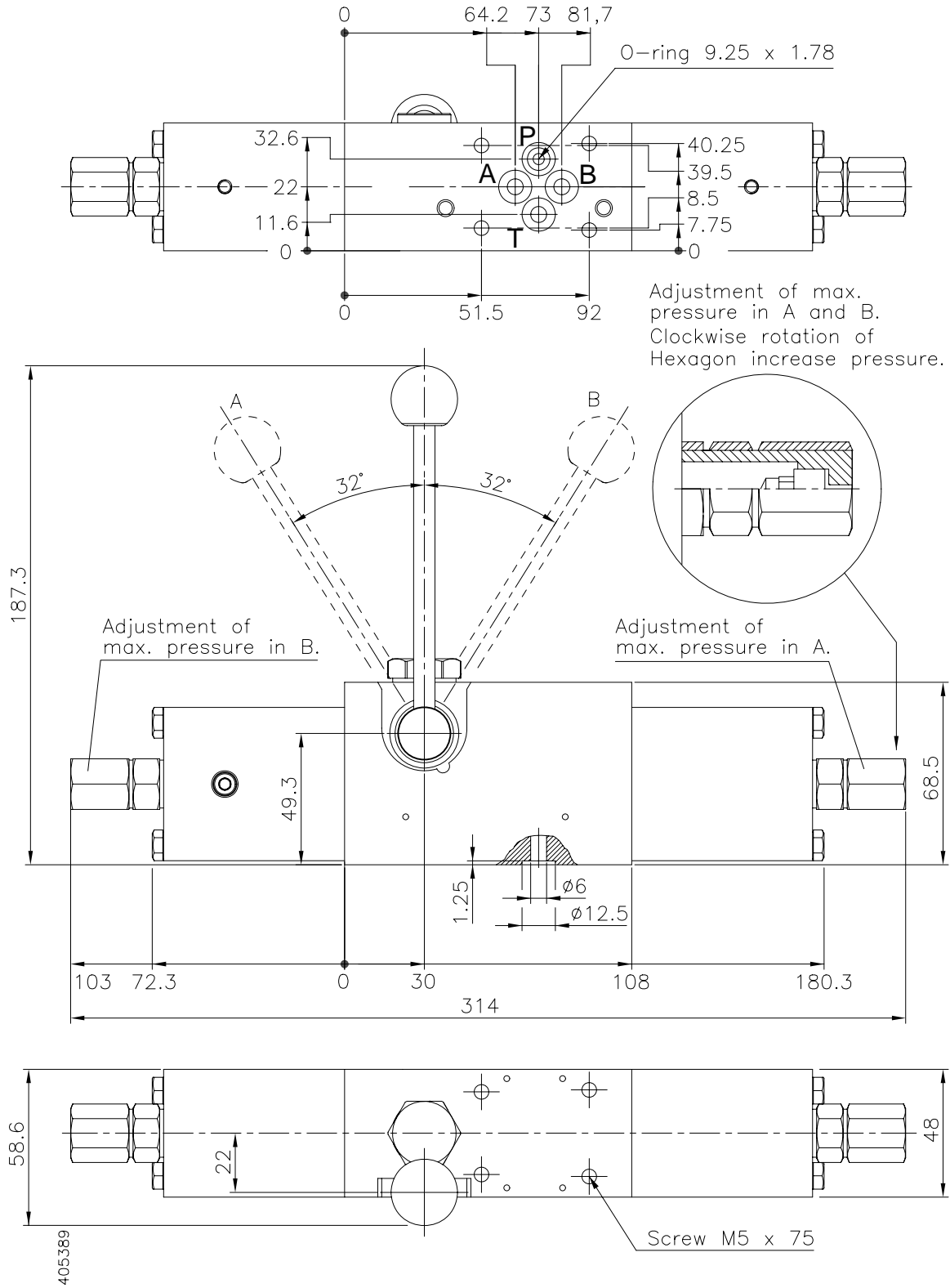

Figure 2 1FGB Dimensions

TECHNICAL DATA

Description	Symbol	Data
Max. pressure in port P	P_{\max}	350 bar
Min nominal pressure in port P	P_{nom}	Pilot pressure + 5 bar
Max. pressure in port T	T_{\max}	10 bar (See note)
Weight		5 kg
Test Pressure	P	420 bar
Hydraulic fluid		Mineral oils for hydraulic system
Viscosity range:	ν	10 to 350 mm ² /s (cSt)
Viscosity index:	VI	> 120
Filtration, recommended filter with $\beta_{20} \geq 100$		Class 9 according to NAS 1638, 18/15 according to ISO 4406
Fluid temperature range:	T	-20°C to + 70°C
Ambient temperature range	T	-20°C to + 50°C
Standard Body Material		EN-GJS-400-15 (GGG 40)
Standard O-rings		Nitrile shore 70

Note: Pressure in port T is directly additional to valve setting.

NOTES:

Avoid fluctuation in pressure port P, to achieve best result of the proportional control. In the Transmitter an orifice diameter 0.8 mm is mounted in port P.

Interfaces:

Description	Type	Tightening Torque
Screws	4 off M5 x 75-DIN 931/933 (To be order separately)	7.0 Nm
	<i>O-rings:</i>	<i>Size [mm]</i>
O-rings	4 off	9.25 x 1.78 mm



INSTALLATION

The Pressure Transmitter Valve 1FGB44*1 is installed with 4 off screws to a SUB plate (ISO 4401). Please refer to 'Interfaces', for details about screws and o-rings.

OPERATION

Manual control performed by the hand lever. The valve is delivered with centring spring, and the spool will return to the neutral position after releasing the hand lever.

PRESSURE ADJUSTMENT

Clockwise rotation of the Hexagon increases pressure.

Install a pressure gauge to the existing port, and turn the hexagon screw until the requested maximum pressure is achieved.

MAINTENANCE

Check the valve for proper function. Visually check the valve and if required, paint unpainted (damaged) areas.

CAUTION: Do not paint the hand lever shaft seal.

SPARE PART

O-ring set is available.

STORAGE

If storage longer than 6 months is expected, the valve must be kept in a dry room, free from dust and protected against sudden large temperature variations. For storage longer than 12 months, the valve must be filled with inhibition oil. Before use check all visible seals and flush with clean oil.

MARKING

Inlets and outlets are marked, refer to figure in section 'General Description'.