

# Electronic drivers type E-ME-T

analog, Eurocard format, for proportional valves with transducer

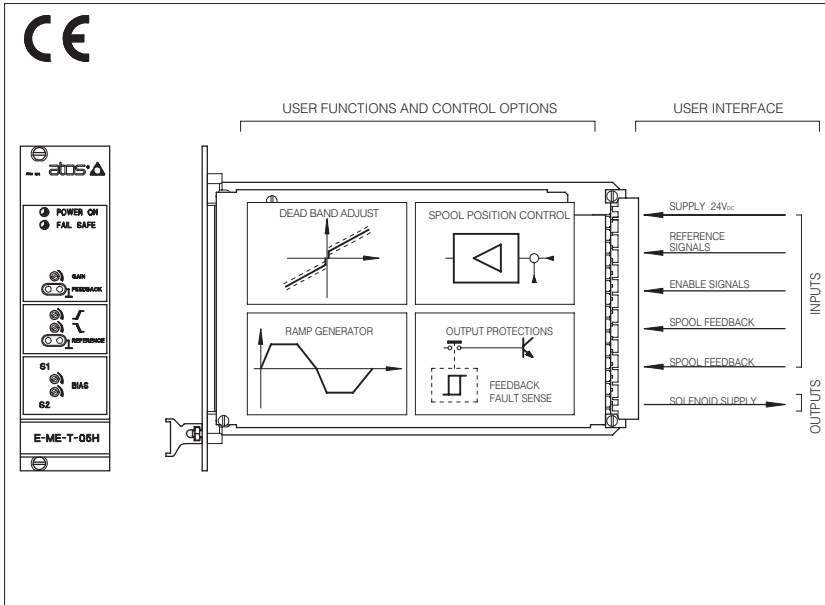

E-ME-T drivers control the current to the solenoid of Atos proportional valves with position transducer, regulating the spool position or the flow according to the electronic reference signal, adjusted by transducer's feedback.

**Features:**

- bias regulation
- scale and dissymmetrical ramps regulation
- voltage (standard) or current (/I option) reference signal
- voltage (standard) or current (/C option) feedback signal
- test point for reference and feedback control on front panel
- factory pre-setted
- Eurocard format (DIN 41494 - plug-in unit)
- electronic filters on input and output lines
- CE marking granting the conformity to the EMC Directive (Electromagnetic compatibility)
- both sides of the card with shielded cover with E faston connector

**Applications:**

Position or flow open or closed-loop regulation systems, according to the block diagram [2].

**1 MODEL CODE**

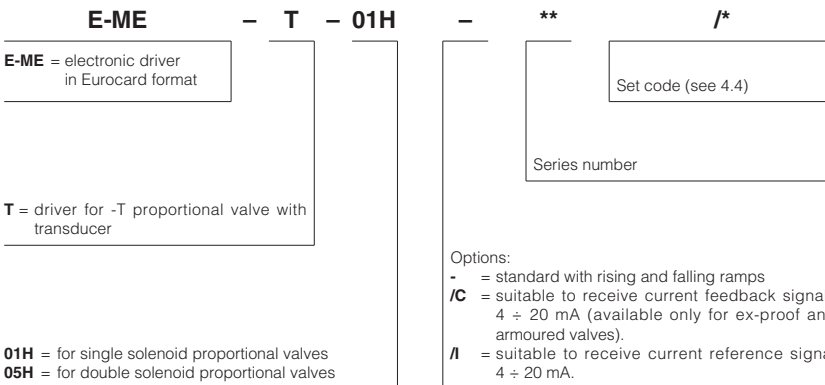

**2 BLOCK DIAGRAM**

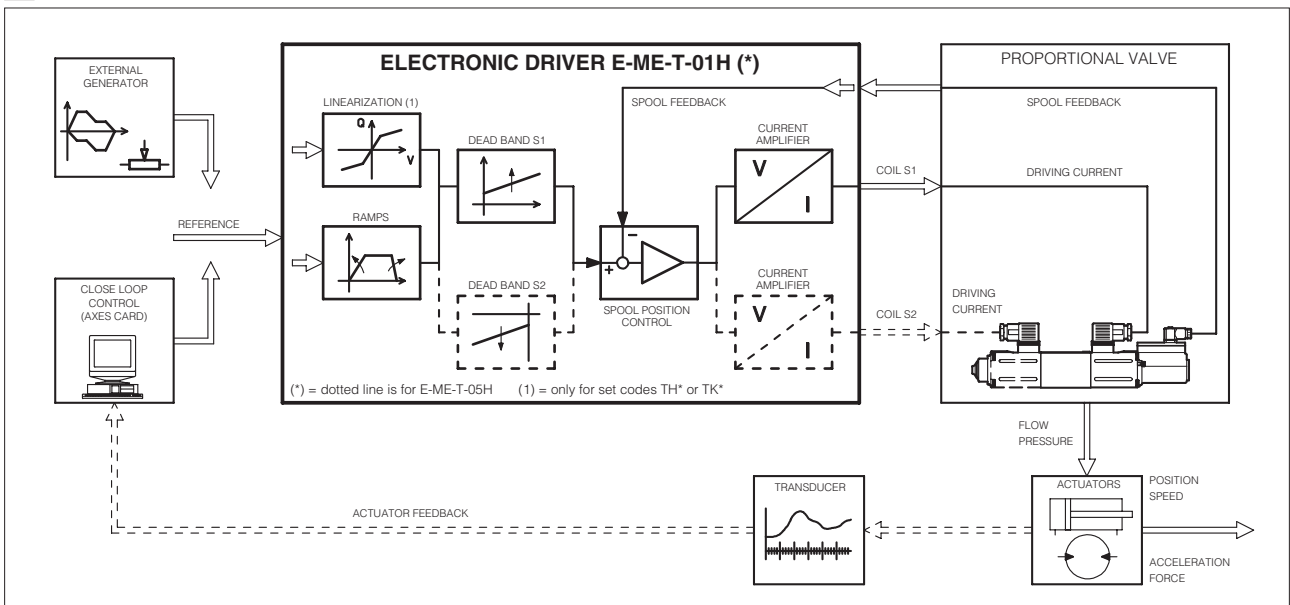

### 3 MAIN CHARACTERISTICS OF E-ME-T ELECTRONIC DRIVERS

Power supply (positive at contacts 2a, 2c) (negative at contacts 4a, 4c)	Stabilized : 24V <sub>DC</sub> Rectified and filtered : $V_{RMS} = 21 \div 33V_{DC}$ (max ripple 2V <sub>pp</sub> )
Max power consumption	50 W
Current supplied to solenoids	$I_{max} = 3,3$ A square wave PWM type (for ex-proof valves $I_{max} = 2,5$ A)
Nominal reference signal, factory preset	E-ME-T-01H : 0 ÷ 10V at contact 12c (GND on 8a) ( $\pm 10V$ option, see 4.4) E-ME-T-05H : $\pm 10V$ at contact 12c (GND on 8a or 16c) for option /I : 4 ÷ 20 mA at contact 12c (+) and 18c (-)
Reference signal variation range (internal scale adjust option)	$\pm 10V$ (SW pos. 1) and $\pm 5V$ (SW pos. 2)
Input signal impedance	Voltage $R_i > 50K$ - (/I option $R_i = 316$ )
Potentiometer supply	+10V / 10 mA at contact 10c and -10V / 10mA at contact 14c
Ramp time	14 sec. max (0 ÷ 100% of reference signal)
Enabling signal	$V = 5 \div 24V_{DC}$ on contact 8c with led indicator on panel; $R_i \geq 30$ k $\Omega$ (max 3 mA)
Electrical wiring	Coil: : 2 x 1 mm <sup>2</sup> to 20 m 2 x 1,5 mm <sup>2</sup> shielded to 40 m Transducer: : 4 x 0,25 mm <sup>2</sup> to 20 m 4 x 0,5 mm <sup>2</sup> shielded to 40 m
Card format	Europa 100x160 mm (Plug-in unit DIN 41494)
Card connector	Male DIN 41612 /D
Connector elements available	Type E-K-32M frame snap connector (see table G800) <b>to be ordered separately</b>
Operating temperature	0 ÷ 50 °C (storage -20 ÷ +70 °C)
Front panel dimensions	128,4 x 35,3 mm
Weight	520 g
Features	Position control by PID action - Fast solenoid excitation and switching off. Outputs to solenoids protected against accidental short circuits. Feedback cable break produces an inhibition of the driver, zeroing the current and creating a fail-safe position in the valve. Only for set codes TH* or TK*: circuit to make linear the regulation characteristic of the valve.

### 4 GENERAL SPECIFICATIONS

#### 4.1 Power supply and wirings

The power supply must be appropriately stabilized or rectified and filtered. If the power supply is generated by a single phase rectifier, use a 10000 $\mu$ F/40V capacitor; if pulse voltage is generated by a three phase rectifier connect a 4700 $\mu$ F/40V capacitor (see [12]).

Connect the reference signal to the main electronic control by means of shielded and twisted cables. Pay attention: the negative and the positive poles must not be exchanged each other.

Shield the wirings to avoid electromagnetic noise (EMC).

It is suitable to keep the driver and its cables far from any electromagnetic radiation source (like cables where high currents flow, electric motors, transformers, relays, solenoids, portable radio-transmitter, etc.).

Wire the earth connection as shown in [12], according to CEI EN 60204-1 standards.

Connect the shield of the driver to the noiseless earth terminal (TE) [14].

#### 4.2 Reference signal

The electronic driver is designed to receive external voltage or current reference signals according to [5].

Note that drivers suitable to receive current reference (option /I) have reference signal values in the range 4 ÷ 20 mA.

#### 4.3 Enabling signal

The digital signal on contact 8c allows to enable (24 V<sub>DC</sub>) or disable (0 V) the driver without switching off the power supply; use this signal to cyclically inhibit the driver or in emergency conditions

#### 4.4 Set code

Basic calibration of the electronic driver is factory preset according to the proportional valve it has to be coupled with. These pre-calibrations are identified by a standard number in the model code as follows:

DHZO-T-05*	= DH05SA	DPZO-T-17*	= DP17SD	DLHZO-T-0*-T7	= TH04SA
DHZO-T-05*/B	= DH05SA	DPZO-T-17*/B	= DP17BD	DLKZOR-T-1*-T	= TK14SC
DKZOR-T-15*	= DK15SB	DPZO-T-27*	= DP27SC	DLHZO-T-T51	= TH06SA
DKZOR-T-15*/B	= DK15SB	DPZO-T-27*/B	= DP27BC		
		DPZO-T-37*	= DP37SC	LIQZO-T-162	= TQ16SA
DHZO-T-070	= DH06SA	DPZO-T-37*/B	= DP37BC	LIQZO-T-252	= TQ25SA
DHZO-T-070/B	= DH06BA	DPZO-T-67*	= DP67SA	LIQZO-T-322	= TQ32SA
DKZOR-T-170	= DK16SA	DPZO-T-67*/B	= DP67BA	LIQZO-T-402	= TQ42SA
DKZOR-T-170/B	= DK16BA			LIQZO-T-502	= TQ52SB
DHZO-T-07*	= DH07SA	DLHZO-T-0*	= DH04SA		
DHZO-T-07*/B	= DH07BA	DLHZO-T-0*/B	= DH04SA	QVHZO-T-06/*	= QV0NSA
DKZOR-T-17*	= DK17SB	DLKZOR-T-1*	= DK14SC	QVKZOR-T-10/*	= QV1NSB
DKZOR-T-17*/B	= DK17BB	DLKZOR-T-1*/B	= DK14SC		

For **ex-proof valves**, insert an "A" in the fifth digit of the code adjustment; for example, the code adjustment for DLHZA-T is DH04AA (see table E120).

#### 4.5 Calibration/settings available to the user, see [7], [8], [9], [10]

##### Scale, see [7]

The Scale regulation, available on the card side, permits to modify the relation between the reference signal and the position or the regulated flow.

Modifying this regulation it is possible to fit the valve hydraulic behaviour to the effective system conditions; in addition the two regulations available for double solenoid valves (driver E-ME-T-05H) permit to set different hydraulic adjustments for positive and negative movements.

The Scale regulation is factory set in order to control the max valve opening with 100% of the reference signal (10V)

##### Bias, (dead band compensation).

The bias regulations, available on the front panel (P1, P2), permit to set the correspondence between the electrical zero of the reference signal with the beginning of the valve's hydraulic regulation, compensating the dead band and the component's mechanical tolerances.

Modifying this regulation (see [9], [10]) it is possible to fit the valve hydraulic behaviour to the effective system conditions; in case of drivers for double solenoid valves (E-ME-T-05H) the bias are active only when the reference signal is over the threshold value =  $\pm 200$  mV.

This regulation is factory set at the standard values depending to the proportional valve to be controlled and it is identified by the driver set code (see 4.4)

##### Ramps, see [7], [11], [12].

The ramp regulation, available on the front panel, permit to modify the time in which the valve reaches the set opening value in front of a step change of the reference signal.

The ramp regulation is factory set at value close to zero and it can be increased up to 14 sec max for a step change of the reference signal from 0% to 100%.

### 5 EXTERNAL REFERENCE SIGNALS

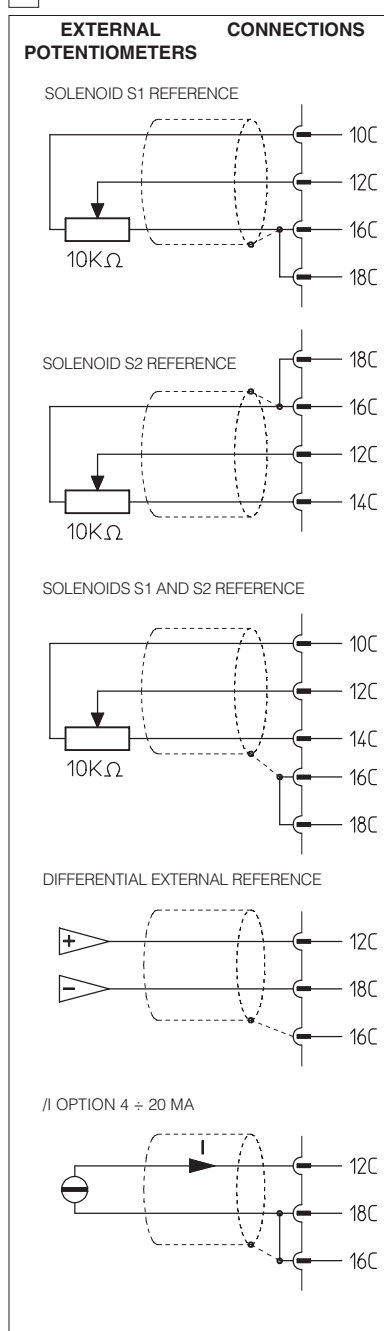

The two available regulations P3 and P4 permit to respectively regulate the ramp times for positive and negative variations of the reference signal. In case of application of the driver in closed loop systems, it is advisable to disable the ramp function: it is possible to permanently disable this function by means of a switch on the card side (7) or temporarily, connecting the pin 6c and 6a (12)

**Gain**, see 8 (only for adjustments TH\* and TK\*).

Pressure gain adjustment around "zero" increases sensitivity and positioning accuracy of the axis and optimize the valve operation according to the stiffness of the system by increasing the hydraulic gain of the valve around the hydraulic zero.

## 6 INSTALLATION AND START-UP

### 6.1 Warning:

- Do not insert or remove the driver while the electronic system is energized
- Connect the electronic driver according to the desired connection scheme (see 11, 12)
- The voltages must be always measured in reference to the GND (pin 8a of the connector)
- Refer to 8 to identify the components mentioned in the setting procedure
- To check the reference signal and the regulated valve opening, use the test points T1 and T2 the on front panel.
- To check the correct solenoid command for positive and negative regulations, use the two led S1 and S2 (only for drivers E-ME-T-05H)

### 6.2 Start-up

It is possible that the factory settings do not match the required performances for the specific application. The system can be optimized on field, by setting in sequence the bias, scale and ramp potentiometers.

It is advisable to perform calibration procedures in the order given below.

**Bias adjustment** (dead band compensation), see 8, 9, 10.

- Supply a reference signal voltage (0 Vdc for E-ME-T-01H and  $\pm 0,2$  Vdc for E-ME-T-05H;
- Gradually turn potentiometer(s) (P1 for coil S1 and P2 for coil S2) until a movement of the controlled actuator is obtained.
- Turn slowly in the opposite sense until stop is obtained.

**Scale adjustment**, see 7, 9, 10

Set the switch A (see.....) depending to the selected range of the reference signal.

In case it is required the regulation of the valve max opening, proceed as follow:

- supply max reference signal (for E-ME-T-05H driver repeat for max negative voltage) in the specified range and turn counterclockwise internal scale potentiometers P5 and P6 (factory preset to 100%) to reduce valve opening (see 7-C).

**Gain** see 8, 9 (only for adjustment TH\* and TK\*).

Front panel potentiometer P7 could be rotated to increase sensitivity and positioning accuracy of the axis (clockwise rotation = increase in sensitivity). Factory preset completely counterclockwise).

**Ramps** (see 7, 8).

If the card is being used in an open loop system push the switch from position ramp off (standard) to position ramp on, (see 7-B). Calibrate the ramp settings only if dynamic impacts and tendencies towards instability persist after optimizations of the whole system. Adjust the ramp settings using the ramp potentiometers (P3 and P4) until the phenomenon has been eliminated (Clockwise rotation = increase in ramp time).

## 7 RAMPS AND SETTINGS

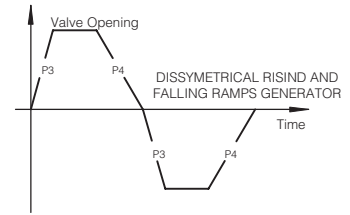

CONNECT TO AN EFFICIENT EARTH POINT

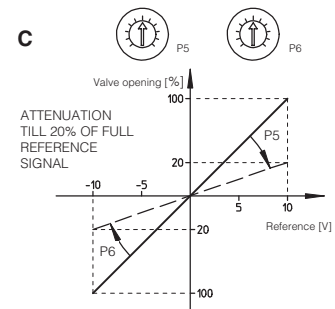
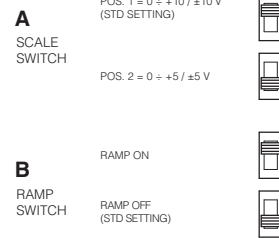
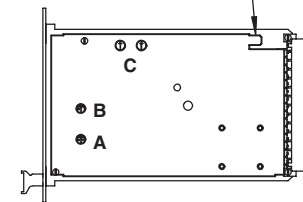

## 8 E-ME-T-05H TOPOGRAPHICAL VIEW OF REGULATIONS

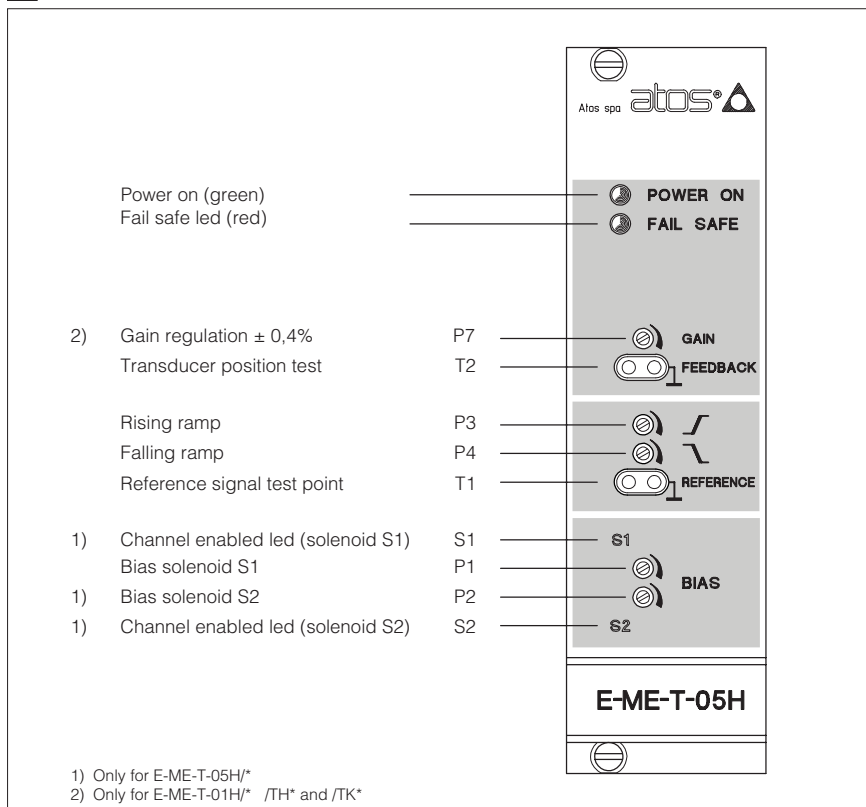

## 9 E-ME-T-01H DIAGRAM

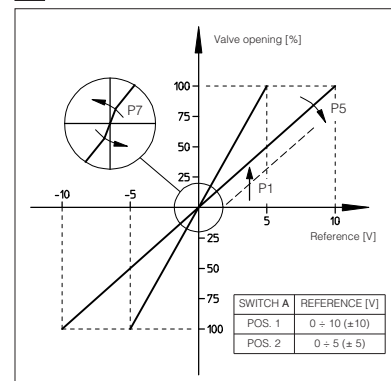

## 10 E-ME-T-05H DIAGRAM

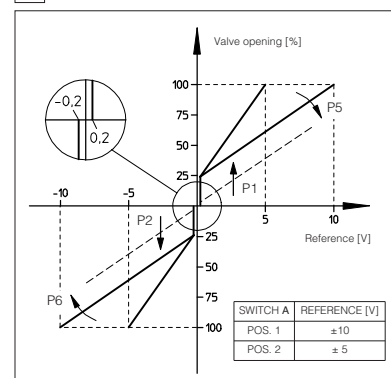

## 11 IMPORTANT INSTRUCTIONS

### ELETTROMAGNETIC COMPATIBILITY

Atos electronic drivers and proportional valves are designed according to the 2004/108/CE Directive (Electromagnetic Compatibility) and according to EN 50081-2 (Emission) and EN 50082-2 (Immunity) standards. The electromagnetic compatibility of electronic drivers is valid only for wirings realized according to the typical electric connections shown in this technical table.

The device must be verified on the machine because the magnetic field may be different from the test conditions.

### SAFETY

The electrical signals (for example reference signals, feedback and enable signal) of electronic drivers must not be used to realize safety conditions of the machine. This is in accordance with the provisions of european directives (Safety requirements of fluid technology systems and components-hydraulics, EN 982). Special attention must be paid to switch-on/switch-off of electronic drivers because they could produce uncontrolled movements of actuators operated by the proportional valves.

## 12 WIRING BLOCK DIAGRAM

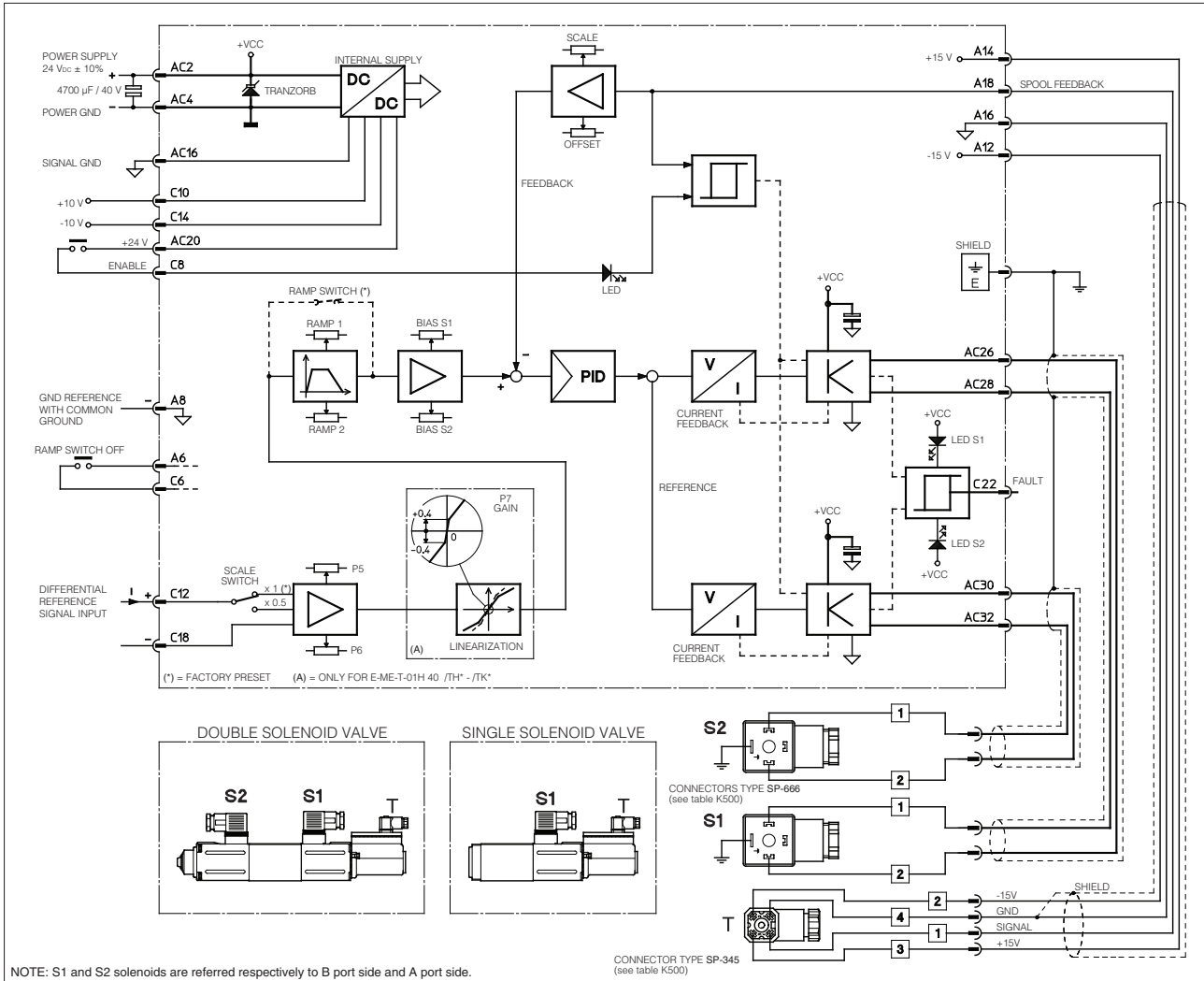

## 13 GENERAL CONNECTIONS

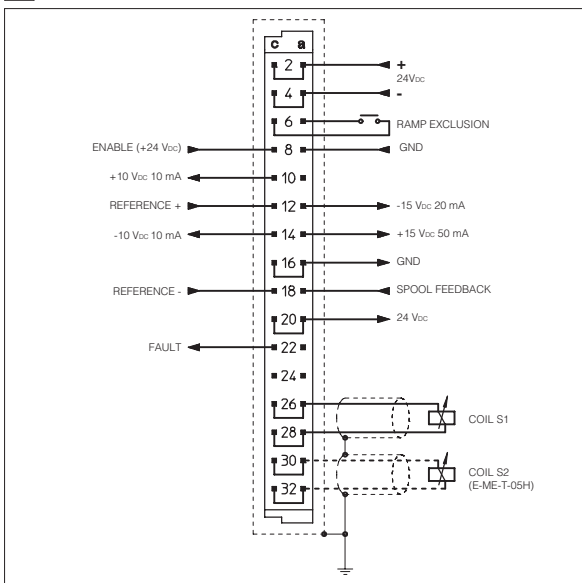

## 14 EARTH CONNECTIONS

