

FHP 500



FHP

SERIES 500

Working pressure
420 bar

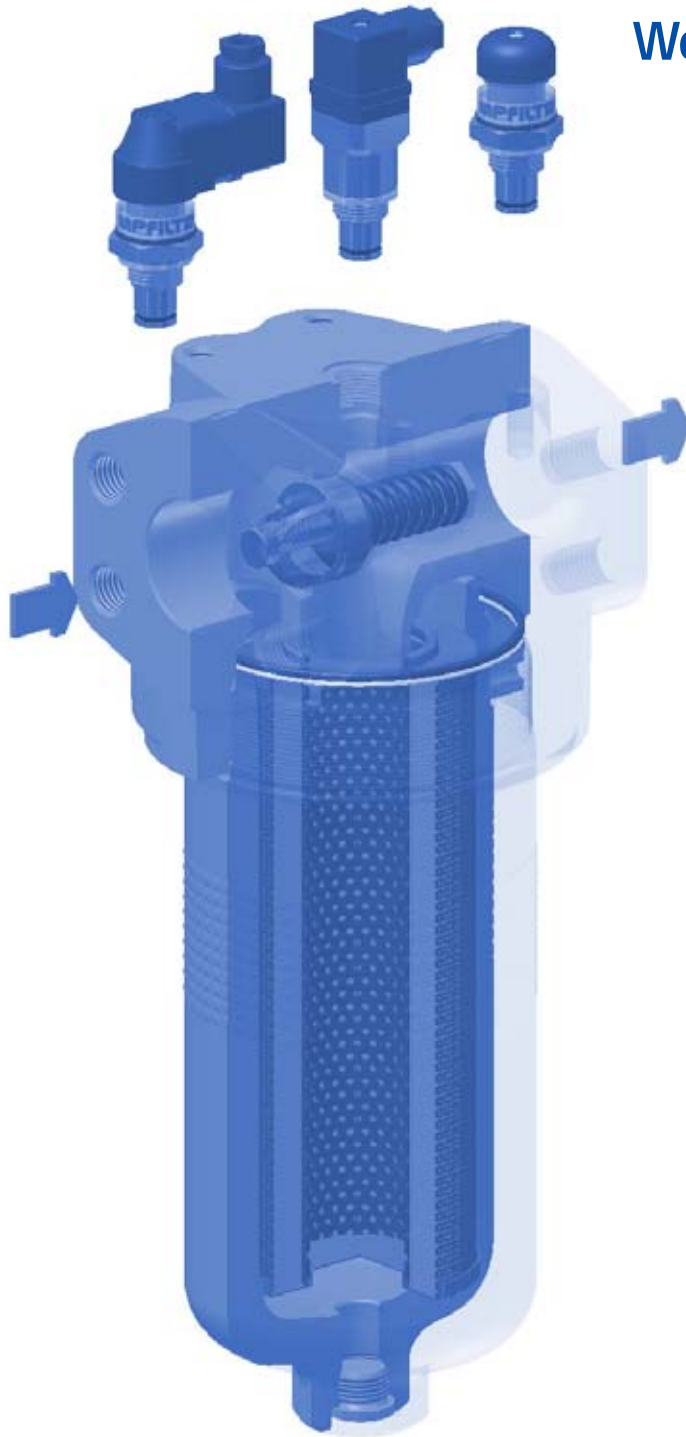

Style S

Style B

Style T

Style D

Style V

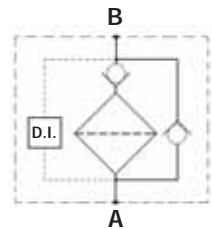
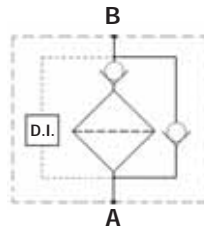
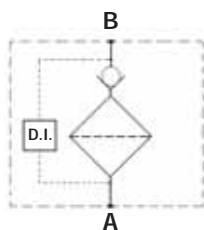
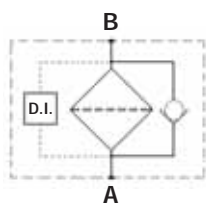
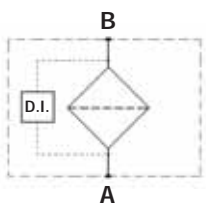

Technical data

Filter body (Materials)

- Head: Cast iron (chemical heat treatment)
- Housing: Steel (chemical heat treatment)
- Bypass valve: Steel
- Reverse Flow: Steel
- Check valve: Steel

Pressure

- Maximum operating pressure: 420 bar (42 MPa)
- Test pressure: 630 bar (63 MPa)
- Burst pressure: 1250 bar (125 MPa)
- Pulsed pressure fatigue test 1,000,000 of cycles with pressure from 0 to 420 bar (42 MPa)

Temperature

- From -25°C to +110°C

Bypass valve

- Opening pressure 6 bar \pm 10%
- Other opening pressures on request.

Elements type Δp

- Elements in microfibre series N: 20 bar
- Elements in microfibre series S: 210 bar
- Elements in stainless steel mesh series N: 20 bar
- Oil flow from exterior to interior.

Seals

- Standard Nitrile (NBR) series A
- Optional FPM series V

Weights without filter elements (kg.)

Length	1	2	3	4	5
• FHP 500	27	31	35	46	53

Filter internal volumes (dm³)

Length	1	2	3	4	5
• FHP 500	2.66	3.39	4.02	5.26	6.59

Connections

In-line Inlet/Outlet

Compatibility

- Bodies compatible with:
Mineral oils to ISO 2943 - aqueous emulsions
Synthetic fluids, water/glycol.
- Filter elements compatible with:
Mineral oils to ISO 2943 - aqueous emulsions
Synthetic fluids, water/glycol.
- Nitrile (NBR) seals series A, compatible with:
Mineral oils to ISO 2943 - aqueous emulsions
Synthetic fluids, water/glycol.
- V series FPM seals, compatible with:
Synthetic fluids type HS-HFDR-HFDS-HFDU.
To ISO 2943

Filter Element Area

Filter element in stainless steel mesh

Type	Length				
	1	2	3	4	5
HP500	3030	4900	6500	9800	13000

Values expressed in cm²

Pressure drops Δp Housing

The curves are plotted using mineral oil with density of 0.86 kg/dm³ to ISO 3968.

Δp varies proportional with density.

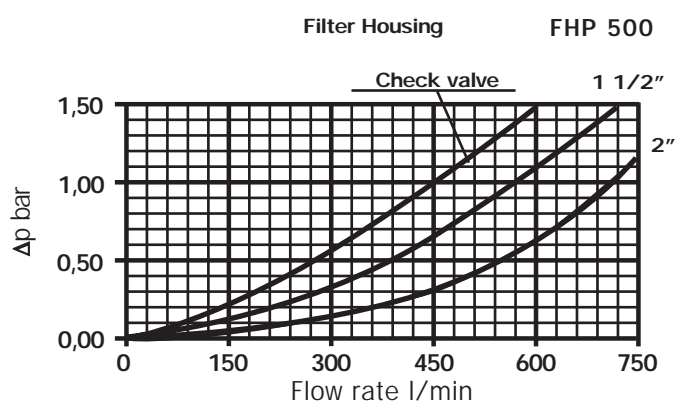

Bypass valve pressure drop

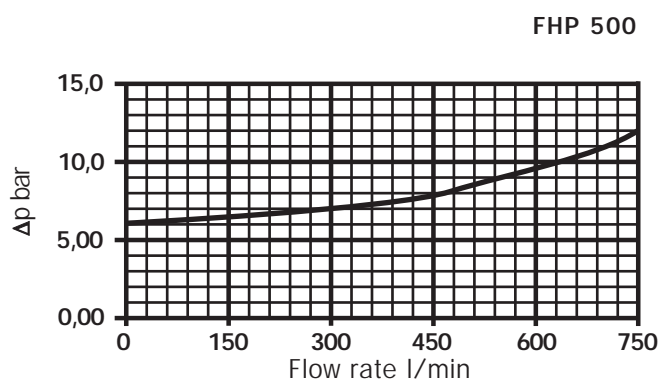

Bypass valve pressure drop

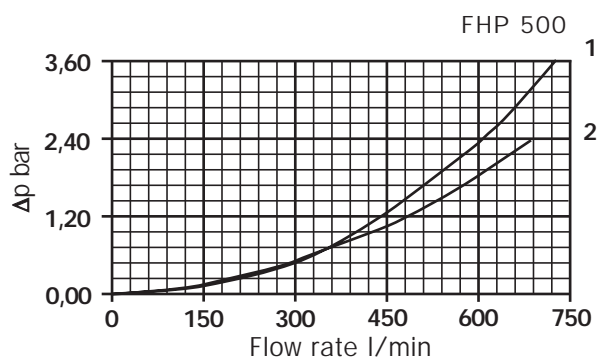

1 - Reverse Flow
2 - In filter direction

FHP 500

Dimensions

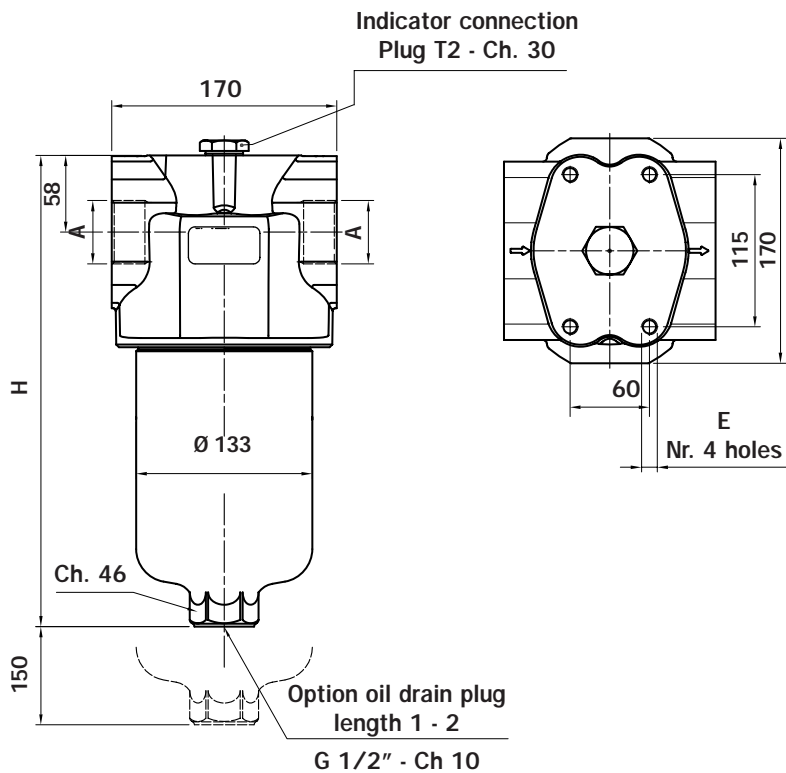

Only for FHP 500 length 4/5

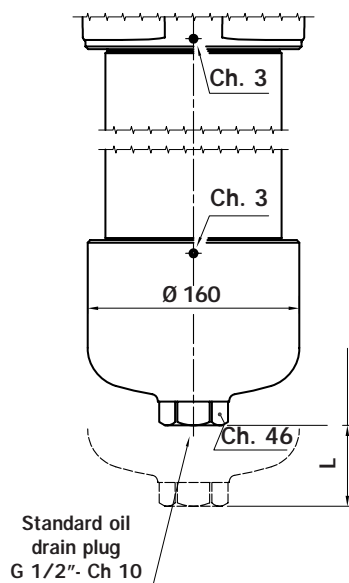

Style P01	
L mm	Filter length
150	4/5

Style P02	
L mm	Filter length
480	4
650	5

Style P01 standard maintenance from head.
Style P02 maintenance option from housing base.

Filter Length	H mm
1	335
2	424
3	500
4	657
5	823

A	E
Threaded Connections	Depth 15 mm
G 1 1/2"	M12
1 1/2" NPT	1/2" UNC
SAE 24 (1 7/8"- 12 UN)	1/2" UNC

Recommended maximum flow rate

- Pressure drop of complete filter equal to Δp 1.5 bar.
- Oil kinematic viscosity 30 mm²/s (cSt).
- Density 0.86 kg/dm³.
- Connections of filter under test FLANGE 2" SAE 6000 PSI.

Filter element type	Flow rate l/min Series N	Flow rate l/min Series S	Filter Length
A03	280	140	1
A06	300	165	
A10	370	260	
A16	370	275	
A25	430	370	
M25	650	-	2
A03	315	240	
A06	325	270	
A10	425	350	
A16	450	360	
A25	480	425	3
M25	700	-	
A03	390	290	
A06	400	300	
A10	465	390	
A16	470	410	4
A25	500	450	
M25	700	-	
A03	550	390	
A06	600	450	
A10	650	465	5
A16	650	600	
A25	700	650	
M25	750	-	
A03	600	515	
A06	645	520	5
A10	680	645	
A16	710	650	
A25	750	720	
M25	750	-	

A Flanged Connections E Depth 15 mm

1 1/2" SAE 3000 psi/M	M12
1 1/2" SAE 3000 psi/UNC	1/2" UNC
2" SAE 3000 psi/M	M12
2" SAE 3000 psi/UNC	1/2" UNC
1 1/2" SAE 6000 psi/M	M12
1 1/2" SAE 6000 psi/UNC	1/2" UNC
2" SAE 6000 psi/M	M12
2" SAE 6000 psi/UNC	1/2" UNC

Spare parts FHP 500

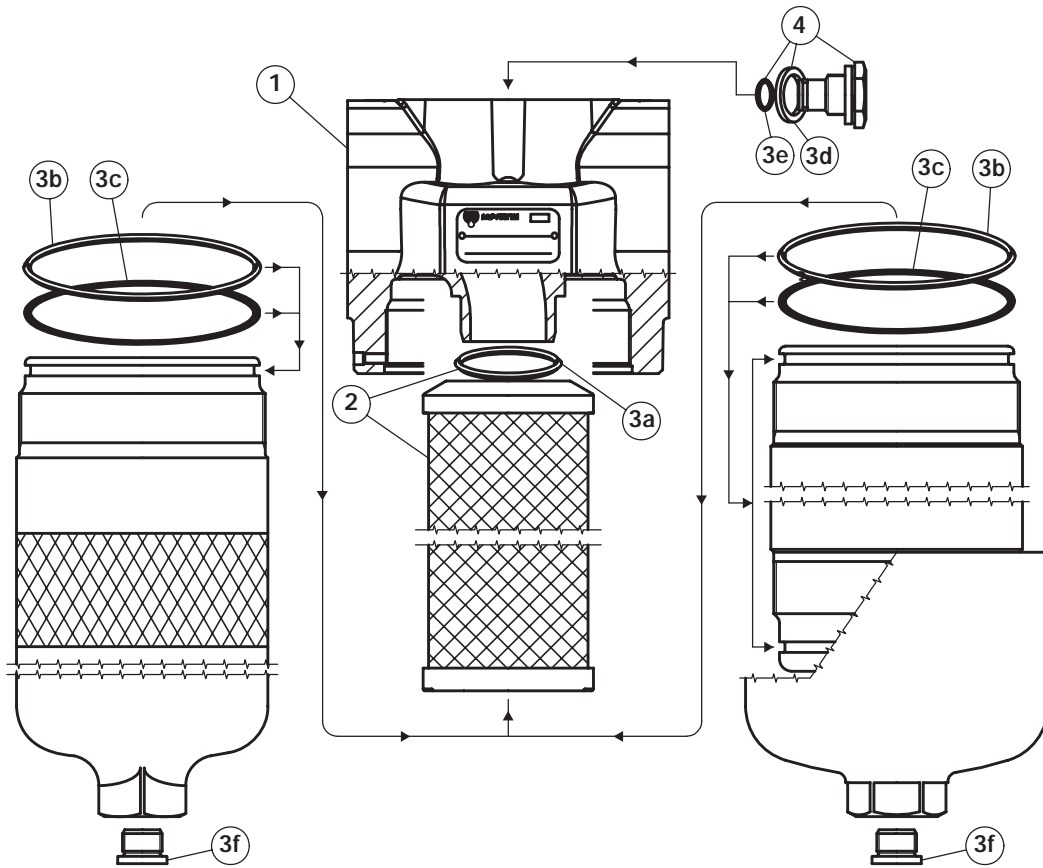

Pos.	Description	Qty.	FHP 500 Series FILTER 500 1 - 2 - 3 - 4 - 5	
1	Complete filter	1	See order table	
2	Filter element	1	See order table	
3	Seal kits	1	NBR 02050330	FPM 02050331
3a	Filter element O-Ring	1	OR 153 Ø 49,21 x 3,53	
3b	O-Ring for housing	2	OR 4462 Ø 117,10 x 3,53	
3c	Anti-extrusion ring	2	Parbak 247 Ø 117,63 x 3	
3d	Gasket	1	01030058 (HNBR)	01030046 (FPM)
3e	O-Ring	1	OR 2050 Ø 12,42 x 1,78	
3f	Oil drain plug	1	G 1/2" with seal	
4	Indicator plug	1	T2H	T2V
-	Indicators	1	See order table	

Ordering information FHP 500

Filter assembly

FHP 500

Example: FHP500

Filter element

HP 500

Example: HP500

	1	2	3	4	5	6	7 _a
FHP 500	<input type="checkbox"/>	<input type="checkbox"/>	<input type="checkbox"/>	<input type="checkbox"/>	<input type="checkbox"/>	<input type="checkbox"/>	<input type="checkbox"/>
Example: FHP500	4	B	A	G1	A10	N	P01
Filter element	1	5	3	6	7_b		
HP 500	<input type="checkbox"/>	<input type="checkbox"/>	<input type="checkbox"/>	<input type="checkbox"/>	<input type="checkbox"/>		
Example: HP500	4	A10	A	N	P01		

1 - Filter length

- 1
- 2
- 3
- 4
- 5

5 - Filter elements

- A03 Inorganic microfibre 3 μ
 - A06 Inorganic microfibre 6 μ
 - A10 Inorganic microfibre 10 μ
 - A16 Inorganic microfibre 16 μ
 - A25 Inorganic microfibre 25 μ
 - M25 Stainless steel mesh 25 μ (style N only)
- βx (c) ≥ 1000
See page 10

2 - Bypass valve

- S Without bypass
- B With bypass
- V With Reverse Flow*
- D With bypass + check valve*
- T Without bypass + check valve*

*Reduced cross-section oilways

6 - Filter elements collapse pressure

- N 20 bar
- S 210 bar

3 - Seals

- A NBR
- V FPM

4 - Connections

- G1 G 1 1/2"
- G2 1 1/2" NPT
- G3 SAE 24 (1 7/8" 12 UN)
- F1 1 1/2"SAE - 3000 PSI/M
- F2 1 1/2"SAE - 3000 PSI/UNC
- F3 2"SAE - 3000 PSI/M
- F4 2"SAE - 3000 PSI/UNC
- F5 1 1/2"SAE - 6000 PSI/M
- F6 1 1/2"SAE - 6000 PSI/UNC
- F7 2"SAE - 6000 PSI/M
- F8 2"SAE - 6000 PSI/UNC

7 - Options

a) Filter

- P01 MP Filtri standard
- P02 MP with replacement of the filter element from the cap (only for length 4 and 5)
- P03 Oil drain plug (only for length 1 and 2) (standard only for length 3 - 4 - 5)
- Pxx Customer request

b) Filter element

- P01 MP Filtri standard
- Pxx Customer request

DIFFERENTIAL INDICATORS (see page 15)

MP Filtri - The filter functions as described in this bulletin are valid exclusively for original MP Filtri filter elements and replacement parts. All rights reserved

The data in this publication is marketing information. MP Filtri reserves the right to make changes to the product described herein at any time it deems fit in relation to technical or commercial requirements. The colors of the products shown on the cover are for illustration purposes only.
Copyright. All rights reserved.