



NITROGEN INFORMATIONS

0.4



HYDRAULIC FLUIDS

0.5



PED 97/23/EC

0.6



DM 329

0.7



ATEX 94/9/EC

0.8

BOILING POINT: -195,79 °C
 MELTING/FREEZING POINT: -209,99 °C
 VAPOUR DENSITY at 0 °C: 0,97 (air = 1)
 CRITICAL TEMPERATURE: -146,9 °C
 DENSITY: 1,25 Kg/m³
 ATOMIC MASS: 14,0067

0.4.5 SAFETY

Name: Compressed Gas
 Non-flammable, non-toxic gas
 Classification of the substance: product not classified as hazardous under current regulations.
 Classification according to Directive 67/548/EEC: not listed
 Classification EC 1272/2008: H280 compressed gas.
 UN n°: 1066
 H.I. n°: 20
 ADR classe: 2
 Classification code ADR/RID: 1 A
 CAS n°: 07727-37-9
 CEE n°: 231-783-9

Note: for use and transport of the pressure vessel containing nitrogen follow all relevant national and international regulations.

0.4.6 HANDLING AND STORAGE

Use only specified equipment suitable on the product, to the pressure and temperature work.

Store the accumulators and/or the shells at a temperature below 50° C in a ventilated environment.

The UNI EN 1089-3 provides a system of identification of commercial compressed gas bottles with color codes of ogives; for nitrogen the ogive is colored in black RAL 9005



0.4d

0.4.7 ECOLOGICAL INFORMATION

Toxicity: does not create any ecological damage

Disposal: Dispose in the atmosphere in a well ventilate area.

Reproduction is forbidden.

In the spirit of continuous improvement, our products may be changed.

0.4.1 NITROGEN

Nitrogen is a colorless and odourless gas. Its chemical symbol is N, its atomic number is 7, its atomic mass 14.0067, at room temperature it is gaseous, non-flammable; it's a dry gas that does not promote corrosion.



0.4a

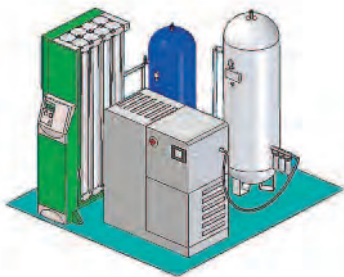
Nitrogen was discovered in Scotland in 1772 by Daniel Rutherford, uncle of Sir Walter Scott and simultaneously, but independently by Joseph Priestley and Henry Cavendish in England and by Carl W. Scheele in Sweden. The French chemist Antoine L. Lavoisier proved that it was a chemical element and named it "azote", in fact the French have used until recently the symbol Az. The symbol N derived by nitrogen, compound word from the Greek words Nitron and genes, meaning generator of saltpeter, because one of the most important compounds, known to the ancient Greeks, was the saltpeter. From what, all the oxygenated nitrogen compounds are named with the common origin nitro. The name "azote" also comes from the Greek and means lifeless, indicating that does not support the combustion and therefore breathing, but it's not a very appropriate term in view of the fact that nitrogen is one of the fundamental constituents of the living organisms.

0.4.2 NATURAL SOURCES

Nitrogen is the most abundant element that occurs naturally in a free state, in the form of diatomic molecules. The air contains 78.06% by volume of nitrogen (75.5% by weight) and it is also found in gases emitted from volcanoes, hot springs and mines.

The most important nitrogen's mineral is nitrate of Sodium, also known as Chile saltpetre or Chile's nitre.

Nitrogen is also found in seawater in the form of ions, such as the ammonia, nitrites, and nitrates. The nitrogen used in industry is usually obtained from the fractional distillation of air liquid.

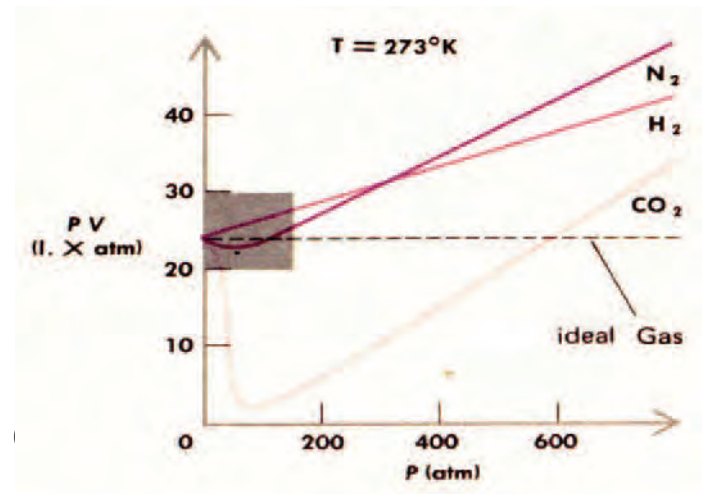


0.4b

If, however, are required only small amounts of nitrogen, it can be prepared by decomposing the compounds.

0.4.3 USE

Gaseous nitrogen is an inert gas due to the high stability of the triple bond that joins the two nitrogen atoms forming the molecule.



0.4c

Nitrogen is mainly used for the synthesis of ammonia, used in turn to produce fertilizers, nitric acid, urea, hydrazine and amines. The liquid nitrogen is used as a super cooling in cryogenics, as its temperature is about -196°C . Because of its low reactivity, gaseous nitrogen is used to form an inert atmosphere within which the substances with high reactivity may be stored or processed in a controlled situation. You can remove water from organic solvents by bubbling nitrogen. Nitrogen is also used to block the oxidation reactions, for example, when the coffee is roasted.

Because of its characteristics, the gas mainly used for the pre-charge of the accumulators is nitrogen. The choice of nitrogen is dictated by its properties of inert gas, in fact, the combination air-oil at high pressure and high temperature can trigger spontaneous combustion (detonation), while nitrogen is not flammable and is stable at the variation of the temperature.

In addition, another advantage of using nitrogen is to reduce the phenomenon of aging of elastomers (bladders, seals, diaphragms), which in contact with air or other gases, could lose or reduce their elasticity in a short time. Nitrogen is easy to find on the market, it is in shells, pressurized to about 200 bar and it is quite cheap.

The pure nitrogen, commercially available, is produced by the fractional distillation of air liquid. Nitrogen, more volatile than oxygen, moves to the head of the distillation column.

For security reasons it is absolutely forbidden to use oxygen or other gases to pre-charge the accumulators.

0.4.4 TECHNICAL DATA

ATOMIC NUMBER: 7

CHEMICAL NAME: nitrogen

CHEMICAL FORMULA: N₂

EC NUMBER: 231-783-9

HAZARDS IDENTIFICATION: not classified as dangerous according to Directive 67/548/EEC

COLOUR: colorless

ODOUR: none

PHYSICAL STATE: gas

PURITY: 99.6 ÷ 99,9 %

defined as "bivalent aliphatic alcohol".

Water glycol has a viscosity slightly higher than the mixture of water and oil and it's less flammable, it has a poor lubricity and is incompatible with zinc plated parts and most of the varnish (with the exception of epoxidic and vinyl).

- Liquid anhydrous: HFD

Anhydrous liquid with properties similar to mineral oil

- Derivatives:
- phosphate acid ester: HFDR
 - chlorinated hydrocarbon: HFDS
 - Mixture of HFDR and HFDS: HFDT
 - other composition: HFDU

0.5.5 SPECIAL LIQUIDS

- Brake fluid: AT

Glycol-based brake fluid.

- SKYDROL

Liquid for use in aeronautics

0.5.6 CLASSIFICATION OF HYDRAULIC OILS

The International Standardization Organization (ISO) has established with the rule 3448 (currently the most widely used in hydraulic oils) a classification of oils according to their viscosity grade (VG). Under this standard, the oils are labeled with letters VG followed by a number corresponding to viscosity of the oil measured in "centistokes" at a temperature of 40 ° C (eg, ISO VG 46). The scale ranges from ISO VG 2 to ISO VG 1500, but the most common grades in use are: 32, 46 and 68.

Viscosity is the resistance that a fluid opposes to the reciprocal flow of its particles. The viscosity of lubricating oil decreases with increasing temperature, so it's normally measured at a given temperature of 40°C.

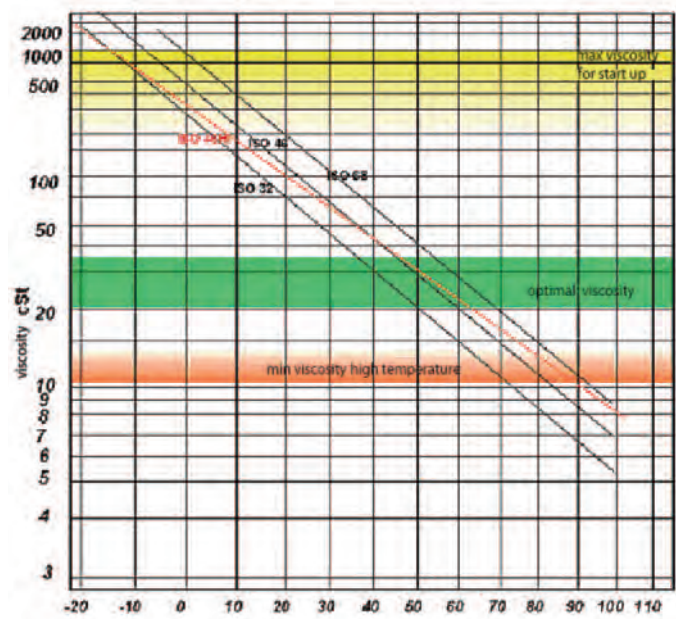
The viscosity of the lubricant determines the thickness of oil film between metal surfaces in reciprocal movement.

The unit of measurement of viscosity that is generally used is centistokes (cSt) or "Engler" (E) degrees.

0.5.7 KINEMATIC VISCOSITY CHANGE DEPENDING ON THE TEMPERATURE

From the table showed below, you can see how temperature changes modify the viscosity of the oil.

The more horizontal is the characteristic oil curve, the better is the behavior of the oil at the temperature changes.



0.5a

ISO gradation	Kinematic viscosity cSt a 40 °C			Medium viscosity °E a 50°C
	min.value	max. value	med. value	
VG 2	1,98	2,42	2,2	1,10
VG 3	2,88	3,52	3,2	1,17
VG 5	4,14	5,06	4,6	1,29
VG 7	6,12	7,48	6,8	1,40
VG 10	9	11	10	1,60
VG 15	13,5	16,5	15	1,90
VG 22	19,8	24,2	22	2,30
VG 32	28,8	35,2	32	3
VG 46	41,4	50,6	46	4
VG 68	61,2	74,9	68	5,7
VG 100	90	110	100	8
VG 150	135	165	150	12
VG 220	198	242	220	16,5
VG 320	288	352	320	24
VG 460	414	506	460	32
VG 680	612	748	680	45
VG 1000	900	1100	1000	66
VG 1500	1350	1650	1500	100

0.5b

Reproduction is forbidden.

In the spirit of continuous improvement, our products may be changed.

0.5.1 HYDRAULIC FLUIDS

The hydraulic fluids, also known as hydraulic liquids, are the means by which the forces and movements are transmitted in the oleodynamic systems; the most common are based on mineral oil or water. In fact, is used the incompressibility of hydraulic fluid to transmit pressure in all directions equally.

The main characteristics of a hydraulic fluids are:

- Low compressibility.
- Low variation in viscosity with temperature variations.
- Stability of chemical composition as the temperature changes.
- Good lubrication circuit (anti-adhesion, low coefficient of friction).
- Hydrolytic stability (ability to maintain the characteristics in presence of high humidity).
- Low pour point (minimum temperature at which the oil is still fluid).
- Ability to separate the water that can enter into the system for leakage from the outside or can be formed by condensation.
- Ability to quickly dispose of the heat produced by the plant.
- Filterability (ability to quickly separate from the dirt around).
- Protection against oxidation and rust.
- Low flammability.
- Resistance to cavitation (formation of air bubbles within the oil, due to sudden pressure changes, which then implode causing erosion in the metal of the pump).
- Low foam production.
- Compatibility with pipes and gaskets.
- Low toxicity and high biodegradability.
- Resistance to aging.

The hydraulic fluid for excellence since the ancient Egypt was the water, from which derived the name "Hydraulic". Since 1920 it has been mostly used mineral oil for its intrinsic lubricating properties and the ability to work even at temperatures where the water is boiling. Later they were also introduced vegetable oils derived from seeds of plants and, with the evolution of chemistry, synthetic oils.

0.5.2 MINERAL OILS

- Unbound Oil: H or HH
Mineral oil without additives, with low capacity lubrication.
- Hydraulic oil HL
Mineral oil resistant to oxidation and rust, but which lack the necessary additives to protect against the risk of wear.
- Hydraulic oil: HM
Anti-wear and detergent mineral oil.
- Hydraulic oil: HV
Mineral oil anti-wear and high viscosity index.
- Hydraulic oil: HG
Anti-wear and detergent mineral oil with anti stick-slip.
- Hydraulic oil: HS
Long-life synthetic oil.

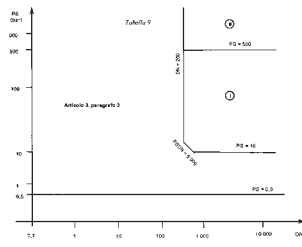
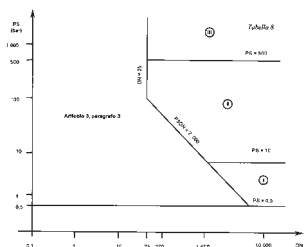
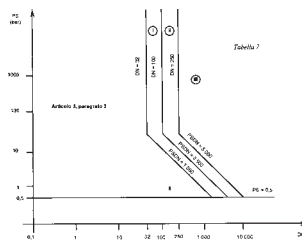
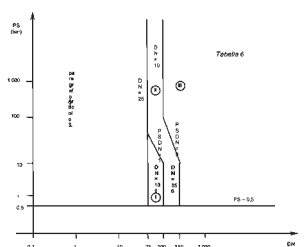
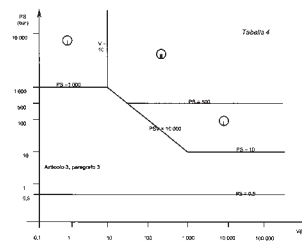
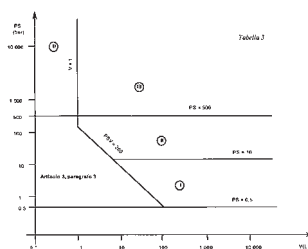
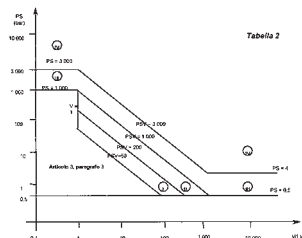
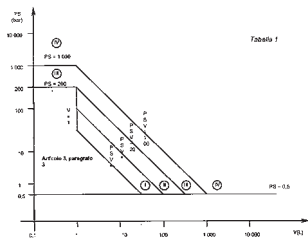
- Hydraulic oil: HLP
Mineral oil with additives to protect against corrosion, oxidation and wear. It's the most common hydraulic fluid.
- Hydraulic oil: HVLP
Mineral oil with additives to protect against corrosion, oxidation and wear but with a viscosity higher than the HLP hydraulic oils. It is used in wider temperature range.
- White oil USDA H1
Mineral oil without additives for use in systems where it might be contact with foodstuffs.
- Mineral oil: MIL-H
Mineral oil usually based naphthenic with extended temperature range. It is mainly used in aeronautics.
- Mineral oil: HD
Mineral oil developed for application in combustion engines.

0.5.3 COMPATIBLE LIQUID ENVIRONMENT

- Natural oil: HETG
Liquid-based natural oil such as rapeseed oil or sunflower oil with additives. These fluids have low resistance to temperatures exceeding 60 ° C. Above this temperature tend to resinify, cake together and premature aging.
- Polyethylene glycol HEPG
Polyethylene glycol-based liquid. Has properties similar to mineral oil.
- Ester synthetic: HEES
Liquid-based carbonic acid ester, ester, polyester. Has properties similar to mineral oil.
- Fluid: HEPR
Acceptable for the environment.

0.5.4 DIFFICULT FLAMMABLE LIQUIDS

- Oil in water emulsion: HFA
Oil in water emulsion with water percentage greater than 80% and minimum percentage of mineral oil greater by 4%, which promotes the lubricity and prevents freezing in systems located outside.
- Water in oil emulsion: HFB
The water in oil emulsion is characterized by a percentage of 50 - 60% of mineral oil. At the obtained emulsion, are normally added additives to improve the properties.
- Aqueous glycolic solution: HFC
Glycolic solution or polyglycolic aqueous solution with water percentage less than 35%.
Glycol, from English words glyc (Erin) and (Alch) ol, is chemically



0.6b

Up to 1,000 bar, the accumulators under a liter capacity are excluded (or better within article 3, par. 3).

- for classes I, II, III, IV is required to issue the Declaration of Conformity and stamp the EC mark, an operation that, for classes II, III and IV is authorized by the Notified Body. In order to stamp the mark, the manufacturer, in each construction phase, must follow the requirements more demanding with increasing risk class. These requirements vary according to the product supplied.

For class I, which covers less dangerous equipments, it is mandatory EC certification without the intervention of the Notified Body. In fact, the PED allows the "self-certification", that is EC marking of the equipment according to the preparation of a technical file able to demonstrate that are satisfied the essential requirements set out in Annex I of the Directive and also justifies the membership product to category I, accompanied by a declaration of conformity issued by the manufacturer and purchaser intended.

- The requests are more heavy in higher classes, up to class IV, in fact:
- for Class II is mandatory EC certification issued by a Notified Body which, without considering the merits of the design, shall carry out the monitoring of production in the manner chosen by the manufacturer;
- for Class III is mandatory EC certification issued by a Notified Body. If

the manufacturer has not certified its quality system including the design, there is also the execution of extensive tests on the prototype which will bear the EC mark;

- for the risk class IV is required the highest level of design and production control. We refer to the safety system (automatically) and sets consisting of vessels + pipelines that use dangerous fluids at high pressures. Class IV is never reached in the case of fluids in Group 2 with vapor pressure less than 0.5 bar (ie: water at temperatures below 110°) whatever the size of the equipment.

Directive 97/23/EC applies only to the productive activities of the equipment under pressure and its sale. The use of the equipment does not fall directly into the European directive, but every State has adopted specific legislation for this purpose. In Italy the rule regarding the use of pressure equipment is the D.M. n° 329 of 01/12/2004.

The user of the component must still obtain the documents relating to the accumulator and should enclose them at the side of the machine.

0.6.2 RELEVANT LEGISLATION

- PED - Directive 97/23/EC (published in Official Journal of the European Communities NL181 / 1 of 09.07.1997) certification of pressure equipment and assemblies placed on the European Community market.
- Legislative Decree No 02/25/2000 93 - Implementation of Directive 92/23/EEC concerning pressure equipment.
- Decree Law No. 329, 01/12/2004 (Published in the Official Journal of General Series No. 22, 28/01/2005) - Regulations for the commissioning and use of pressure equipment and assemblies referred to Article 19 Legislative Decree 25 February 2000, No 93. - certification of pressure equipment and assemblies placed on the European Community market
- T-PED Directive - Directive 99/36/EC (D. Lgs. No. 23 of February 2, 2000) - certification of transportable pressure equipment.

0.6.3 CERTIFIED PRESSURE EQUIPMENT

Gas Accumulators

The accumulators are to be regarded as vessels containing a liquid and a gas, according to Art. 8, paragraph 3, when a vessel is composed of several compartments, it must be classified according to the fluid results in the highest category, should then consider the case of a vessel with gas of group 2 (Nitrogen, gas not dangerous). The classification uses the diagram described in Table 2 of Annex II of the PED

Each accumulator, as it is a pressure vessel, must be provided with a safety valve.

The safety valve can be mounted on the nitrogen side or on the oil side. When the installation location of the accumulator is provided for the fire risk, you must also install a safety device on the gas side (safety valve type VS224TX / ... or burst disk type DR / ... calibrated at a pressure equal to or less than the PS, and / or a fusible disk DF / ... calibrated at a temperature equal to or less than the maximum TS max.

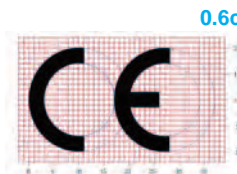
On the pipe that connects the accumulator to the system, you must mount a shut-off device, accompanied by the corresponding discharge.

Pressure relief valves

The pressure relief valves (or security valves) are special accessories directly limiting the pressure in the system. They are therefore part of the "safety system" (art. 1 par. 2.1.3) and must meet the requirements of Annex I of the Directive and be CE marked.

0.6.4 DOCUMENTATION

- Each product must be accompanied by:
- Declaration of CE Conformity
- operating and maintenance manual.



0.6c

0.6.1 PRESSURE EQUIPMENT DIRECTIVE

Pressure Equipment Directive is a directive (97/23/EC) issued by the European Union and transposed in Italy by Legislative Decree No. 93/2000. Until May 30, 2002 it was possible to retain the existing Italian legislation and, from that date, the PED has become mandatory and replaced the previous provisions.

PED governing the design, construction, equipment and installation of pressure devices in safety.

In the field of application of the law are included, for example, pipes, hydraulic valves and vessels under a relative pressure greater than 0.5 bar.

Equipments under pressure with greater pressure of 0.5 bar must be subjected to a preliminary examination to assess whether they fall within the scope of PED and if they are subjected to the requirements of compliance, audit and attestation required by the Directive.

If the preliminary examination is successful, equipments under pressure must satisfy the essential requirements of Annex I of the Directive and then must receive the CE mark followed by the number of notification of the Notified Body.

The PED directive concerns exclusively the marketing of the pressure equipments, in the European Community, but gives no indication on the requirements relating to operation and maintenance of them, which are governed by national regulations.

In Italy all installations of pressure equipments subject to the PED directive must be communicated to the relevant offices of ISPESL or ASL (D.M. n. 329/04).

The Directive has introduced the concept of a Notified Body, which was absent in the field of pressure equipment, such as certifying body for the activities of construction of pressure equipments. The nomenclature has also been enriched by expressions such as "pressure equipment", meaning by this expression each part subject to an internal pressure (piping, pressure vessels, etc.), "pressure accessories" and "safety system", instruments that are aimed to limit the pressure in certain circumstances.

PED identifies the manufacturer as the solely responsible of the production process, assisted in some activities by the Notified Body. Last important innovation was the inclusion of a dedicated procedure for manufacturers operating in certified quality system ISO 9001/2008.

Fall within pressure equipments subjected to PED directive the following single equipment and their assemblies:

- containers: housing designed and built to contain fluids under pressure such as compressors, autoclaves, condensers, gas or steam vessels, reactors, heat exchangers, LPG spheres, etc.
- pipelines: understood as a pipe or system of pipes for the transport of pressurized fluids including any pressure-bearing components such as dismantling joints, expansion joints, flanges, fittings etc.. It does not include for example the water pipes for oil or gas (see paragraphs below);
- pressure accessories: hydraulic valves such as gate valves, butterfly valves, air valves, non-return valves, etc.
- safety controls: devices designed to protect pressure equipment against exceeding the allowable limits, and these include:
 - devices for direct pressure limitation: safety valves, burst disk devices, folding bars, controlled safety devices used for the discharged pressure (CSPRS);
 - limiting devices that activate control systems or that close and disable the equipment: switches, thermostats, fluid level sensors, security devices for measuring, control and regulation (SRMCR).

- sets: consisting of various pressure equipments assembled by a manufacturer to constitute an integrated and functional assembly. The PED requires manufacturers to identify the level of dangerousness of the equipment built. They are required to recognize the risks due to pressure and then to design and build the equipment taking into account this analysis. The threat level is linked to the concept of energy stored in the equipment.

The stored energy is evaluated on the basis of the following parameters:

- size of equipment (volume V in liters in the case of vessels, diameter DN in millimeters in the case of pipes);
- maximum working pressure (PS): maximum pressure in bar, for which the equipment was designed, according to manufacturer's specifications.
- minimum/maximum working temperature (TS): minimum/maximum temperature for which the equipment was designed, according to manufacturer's specifications.
- fluid: pure gas, liquid, vapor or mixtures thereof. They are classified as
 - fluids in Group 1: dangerous. Belong to this group the fluid
 - explosive
 - toxic
 - flammable
 - oxidizing
 - fluids in Group 2: non-dangerous. Belong to this group all those who do not fall into Group 1.

Operating conditions and installation.

According to Annex II of the Directive, depending on the type of equipment under pressure (pipe, vessel, accessories), the parent group of the fluid (dangerous or not dangerous), the physical state of the fluid (gas, liquid) and result of the calculation of $PS \times V$, in the case of containers, $PS \times DN$ in the case of vessels, there are nine tables through which you can define the risk category (I, II, III, IV) of the component, equipment or assembly.

Equipment or assembly acquire the most severe category of risk between the risk categories of pressure equipment of which they belong, while safety accessories are automatically classified in category IV, which corresponds to that of maximum risk.

For the vessels and piping results:

Fluids	Containers	Pipes
gas group 1	table 1	table 6
gas group 2	table 2	table 7
liquid group 1	table 3	table 8
liquid group 2	table 4	table 9

0.6a

Depending on the risk category of pressure equipment, EC certification procedures vary according to the Pressure Equipment Directive.

- In the case of low limits of dangerous equipment (as provided in Article 3, paragraph 3 of the Directive), it will bear no EC marking, so you can place the product on the market accompanied by the necessary information to the purchaser for an appropriate use of the equipment.

on the category.

Regarding to the discipline of the safety at the workplace, the law 81/2008, art. 71 provides that all equipments (including pressure vessels) are subjected to periodic inspections.

The first review is carried out by ISPESL which must execute the task within sixty days from the request. After that period the manufacturer can ask to the ASL to carry out this job to a public or private authorized entity.

Further checks are carried out by ASL, which provides within thirty days from the request after which the employer may make use of public or private entity authorized.

EXEMPTIONS FROM THE REGULAR REDEVELOPMENT

Are excluded from the requirement of periodic requalification:

- a) vessels containing fluids in Group 2, excluding water vapor, which are not subjected to internal or external corrosion, provided the pressure PS is less than or equal to 12 bar and the product of PS and the volume V does not exceed 12,000 bar x l;
- b) vessels with volume less than 1000 liters and pressure PS less than or equal to 30 bar belonging to cooling plants in which are not mounted vessels with volume and pressure greater than those indicated in letter a);
- c) vessels of water vapor self-producers for which the product of pressure PS in bar to volume in liters does not exceed 300 and pressure PS does not exceed 10 bar;
- d) vessels of water vapor does not self-producers for which the product of the pressure PS in bar to volume in liters does not exceed 400 and pressure PS does not exceed 10 bar;
- e) acetylene generators;
- f) the steam converters, traps, condensate separators, oil separators mounted along the pipelines of vapors or gases, filters, receivers and distributors barrels of vapor or gas and power machines belonging to category I and II for which do not occur the conditions laid down in Article 2, paragraph 1, letter o);
- g) All vessels containing liquids of Group 2;
- h) the tubes containing fluids of Group 2 and classified in category I and II;
- i) portable fire extinguishers, powder, foam or water-based with a gas cartridge whose pressure is less than or equal to 18 bar.

PRESSURE EQUIPMENT	LIMITS AND FREQUENCY OF INSPECTIONS
EQUIPMENT/SETS CONTAINING FLUIDS OF GROUP 1 (Legislative Decree no. 93/2000 Art. 3)	
Vessels/Assemblies classified in category III and IV, vessels containing unstable gases belonging to category I to IV, furnaces for the chemical industries and similar, generators and vessels for overheated liquids different than water.	Frequency of inspections: - every 2 years: functional test - every 10 years: integrity test
Vessels/Assemblies classified in category I and II	Frequency of inspections: - every 4 years: functional test - every 10 years: integrity test
Pipelines for gas, vapor and overheated liquids classified in category I, II and III	Frequency of inspections: - every 5 years: functional test - every 10 years: integrity test
Pipelines for liquids classified in category I, II and III	Frequency of inspections: - every 5 years: functional test - every 10 years: integrity test
Vessels for liquids classified in category I, II and III	Frequency of inspections: - every 5 years: functional test - every 10 years: integrity test

0.7a

PRESSURE EQUIPMENT	LIMITS AND FREQUENCY OF INSPECTIONS
EQUIPMENT/SETS CONTAINING FLUIDS OF GROUP 2 (Legislative Decree no. 93/2000 Art. 3)	
Vessels/Assemblies containing compressed gases, liquefied or dissolved or vapor other than water vapor classified in category III and IV and vessels of water vapor and water overheated in category I to IV.	Frequency of inspections: - every 3 years: functional test - every 10 years: integrity test
Vessels/Assemblies containing compressed gases, liquefied or dissolved or vapor other than water vapor classified in category I and II.	Frequency of inspections: - every 4 years: functional test - every 10 years: integrity test
Water vapor generator	Frequency of inspections: - every 2 years: functional test and inside inspection - every 10 years: integrity test
Pipelines for gas, vapor and overheated liquids classified in category III	Frequency of inspections: for TS ≤ 350 °C - every 10 years: integrity test for TS > 350 °C - every 5 years: functional test; - every 10 years: integrity test
Pipelines for liquids	No test
Vessels for liquids	No test
Bottles for breathing apparatus	- for underwater use: initial review every 4 years; following every 2 - for no-underwater use: review every 10 years
Portable fire extinguishers	- No corrosive gas: review every 10 years - Corrosive gas: review every 3 years

0.7b

Reproduction is forbidden.

In the spirit of continuous improvement, our products may be changed.

0.7.1 REFERENCE LEGISLATION

On February 12, 2005 entered into force Decree 1 December 2004, n. 329 by the Ministry of Productive Activities, entitled: "Rules for the commissioning and use of pressure equipment and assemblies referred to Article 19 of Legislative Decree 25 February 2000, No 93" (PED).

SCOPE (article 1)

The DM 329 is applicable to:

- Pressure equipment and "assemblies" as defined by the Decree 93/2000, in particular:
- vessels of gas and liquids;
- generators of steam and hot water;
- piping intended to contain liquids and gases;
- equipment and facilities that existed prior to May 29, 2002 and approved by ISPESL (ANCC) according to the rules in force before April 19, 2000;
- simple pressure equipment regulated by legislative decree 27/09/1991 n ° 311;
- vessels and pipelines for liquids already in service before May 29, 2002 and never subjected to approval (and not falling into the conditions of exclusion provided for in Legislative Decree no. 93/2000).

Articles 4 and 6 of Ministerial Decree 329/2004 take care of the verification of first equipment (or supervision of commissioning) and the obligations of the commissioning with the declaration.

EXCLUSION FROM THE CONTROL OF THE COMMISSIONING

The following equipments and assemblies are excluded from the verification of commissioning:

- portable fire extinguishers and portable cylinders for breathing apparatus;
- simple vessels by Decree-Law No 311/1991 with pressure less than or equal to 12 bar and product pressure by volume lower than 8000 bar x liter;
- pressure vessels, including the simple equipment referred to Legislative Decree 27 September 1991, No 311, with a capacity <25 l and, if the pressure is <12 bar, with a capacity <50 liters.
- the assemblies for which from the relevant notified body or from a user inspectorate are made the verifications of the safety accessories or of the control devices.

COMMISSIONING

The current legislation provides that only for the pressure equipment or assemblies installed and assembled by the user should be done a verification of proper installation, known as first verification system or commissioning.

The test above mentioned must be requested by the user to the relevant ISPESL or ASL referred to art. 4 of the DM 329/2004.

Once the verification of first/new installation is done, the user is required, at the time of commissioning of the equipment/assembly, to send a statement of commissioning to the relevant ISPESL or ASL, which includes a numbered technical documents mentioned in Art. 6 of Decree 329/2004, including the report of the first verification system.

DECLARATION OF COMMISSIONING

The declaration of commissioning, to be sent to ISPESL and to USL or to ASL responsible, must contain:

- a list of the items, with respective values of pressure, temperature, capacity, and the working fluid;
- a technical report, with the plant diagram, containing the conditions of

installation and operation, security measures, protection and control measures adopted;

- an explicit declaration, drawn up under Article 2 of Decree of the President of the Republic of 20 October 1998, no 403, stating that the installation was done according to the operating Manual;
- the report issued by the supervisor and provided to the company at the end of the verification, if required;
- a list of components operating under viscose sliding or subjected to few cycle fatigue.
- the timing of periodical re-testing equipment (article 10 and Tables "Annex A and B" of the DM 329/2004)
- exemption from periodic re-testing (Article 11).

The documentation of the new equipment and/or assembly, built according to the PED, is now made up of the Declaration of Conformity issued by the manufacturer and supplemented by the operation and maintenance manual, rather than the ISPESL booklet that accompanied pressure vessels built in accordance with the previous legislation.

VERIFICATION OF PERIODIC CHECKS:

The current law puts in the hands of the end users of pressure equipment/assembly a number of obligations related to periodical checks which they are subjected.

In particular, users are obliged to:

- Submit equipment/sets to regular checks.
- Exclude from operation the equipment/sets that are not subject to periodic checks on time.
- Encourage and provide the necessary assistance for the conduct of periodic inspections.
- Communicate the decommissioning and/or restart of equipment/assembly.

CLASSIFICATION

The Ministerial Decree 329/2004 provides that the pressure equipment falling within the scope of the decree, should be classified under the categories defined in Annex II of the Decree 93/2000 and, consequently, defined the frequency of checks for the requalification.

The classification must be made by the user even for the equipment in use before the entry into force of Legislative Decree no. 93/2000.

This technical specialist evaluation can be, if deemed necessary by the official ASL/ARPA responsible for periodic review, adequately supported by a specific document showing the appropriate arguments and technical considerations to support the classification made and signed by appropriate technical authority.

FREQUENCY

The Ministerial Decree 329/2004 regulates the frequency of checks according to the two tables annexed to the same Ministerial Decree (Table 0.7a and Table 0.7b).

The classification according to the fluid inside is approximately as follows:

- a) fluids in group 1 include dangerous fluids (fluids are defined as hazardous substances or preparations as defined in Article 2, Section 2, of Legislative Decree no. 52/97, such as "explosive", "extremely flammable", "highly flammable", "flammable" when the maximum allowable temperature is above flashpoint, "highly toxic", "toxic" and "oxidizing") for such cases, the frequency of the periodic examination is two years.
- b) For all the fluids in Group 2 such as air, air/water, nitrogen, argon, carbon dioxide, etc., the frequency may be three or four years depending

0.8.3 MAIN DIFFERENCES BETWEEN AREAS WITH DUST AND GAS

A potentially explosive atmosphere is composed of a mixture of air and flammable substances in the form of gases, vapors, mists or dusts in which, after ignition, combustion spreads to the entire unburned mixture. The main difference between a gas and a dusty atmosphere is the mass per unit volume; that of gas and vapor is about 1000 times smaller than that of powders.

Furthermore, the gases disperse into the air for convection and diffusion to form a homogeneous atmosphere. The powders are much heavier than air and settle more or less quickly.

The powder to be flammable should generally have a particle size less than 0.3 mm and a concentration greater than 50 g/m³.

0.8.4 CONSTRUCTION

All equipments intended for use in areas classified at risk of explosion must be designed and constructed in accordance with ATEX Directive 94/9/EC and according to European standards EN 1127-1 (explosion prevention and protection) and EN 13464-1 (non-electrical equipment for potentially explosive atmospheres).

For example, the hydropneumatic accumulator from the perspective of the ATEX directive is a non-electrical appliance. However, all its components must be analyzed according to the procedures for assessing the compliance to the directive. In addition, the EN 13463-1 defines all the specific requirements of the materials admitted, impact tests, etc.

0.8.5 CLASSES OF TEMPERATURE IN THE ATMOSPHERE WITH GAS

Equipment suitable to operate in a potentially explosive gas atmosphere, have a further specification according to the maximum surface temperature reachable during the operation, which must be less than the ignition temperature of the explosive mixture.

The maximum surface temperature is the highest temperature reached during operation in normal conditions, at any point on the surface of the equipment.

Maximum values of surface temperature according to its class:

- class T1 ≤ 450 °C
- class T2 ≤ 300 °C
- class T3 ≤ 200 °C
- class T4 ≤ 135 °C
- class T5 ≤ 100 °C
- class T6 ≤ 85 °C

Of course, an equipment with the temperature class T4, for example, can also be used in areas with required temperature class T1, T2, T3.

0.8.6 SURFACE TEMPERATURE IN ATMOSPHERES WITH DUST FUEL

In atmospheres with combustible dust, can stir up:

dust layer

dust cloud

In general, the ignition temperatures of dust in the form of a cloud and in the form of a layer are different, so you must calculate the highest temperature between the two, called reference temperature, and use the equipment with surface temperatures lower than the reference.

$T_{cloud} = 2/3 T_{cl}$ (T_{cl} = ignition temperature of dust)

$T_{layer} = T_{5mm} - 75^{\circ}C$ (T_{5mm} = ignition temperature of a 5 mm layer of dust)

$T_{reference} =$ the minor between T_{cloud} e T_{layer}

0.8.7 MARKING ATEX

The CE marking shows certainty that the equipment has been constructed in accordance with the basic requirements and evaluation procedures applicable in the European Union.

The devices, systems and components shall bear the specific marking concerning the explosion protection (symbol "Ex enclosed within a hexagon), already in use before the ATEX directive in compliance with the previous directives concerning explosive atmosphere.

This mark will be followed by the symbol of the group and category and, with regard to group II, the letter "G" (concerning explosive atmospheres caused by gases, vapors and mists) and/or the letter "D" (concerning explosive atmospheres caused by dust).

Example of marking:



II 2 Gc T4

0.8b

II = material destined for surface plants (not mine)

2 = high protection for zone 1

G = occasional presence of explosive gases

c = constructional safety

T4 = 135 °C maximum surface temperature

0.8.4 DOCUMENTATION

Each product must be accompanied by:

- EC declaration of conformity
- operating and maintenance

Reproduction is forbidden.

In the spirit of continuous improvement, our products may be changed.

0.8.1 GENERAL INFORMATION

The abbreviation ATEX (ATmospheres EXplosibles) refers to two European Union directives on the risk of explosion in different areas.

The first ATEX directive (94/9/EC) (ATEX 95) regards the requirements for equipment intended to use in areas at risk of explosion. The second ATEX Directive (99/92/EC) (Atex 137) concerns the minimum safety and health requirements that areas at risk of explosion must satisfy.

These directives, which came into force from July 1, 2003, harmonize and align the different laws of the Member States relating to safety rules and equipment to use in potentially explosive areas. In particular, the ATEX (94/9/EC) identifies different groups and areas of risk, defining the technical/ construction features of the equipment suitable for operating in these groups/areas.

0.8.2 CORRESPONDENCE BETWEEN RISK AREAS AND TYPES OF EQUIPMENT

Zone 0 / 20 Danger constant

Permanent presence of explosive gases (G): Zone 0

Permanent presence of explosive gases and / or combustible dust (D) zone 20.

Zone 1 / 21 Potential danger

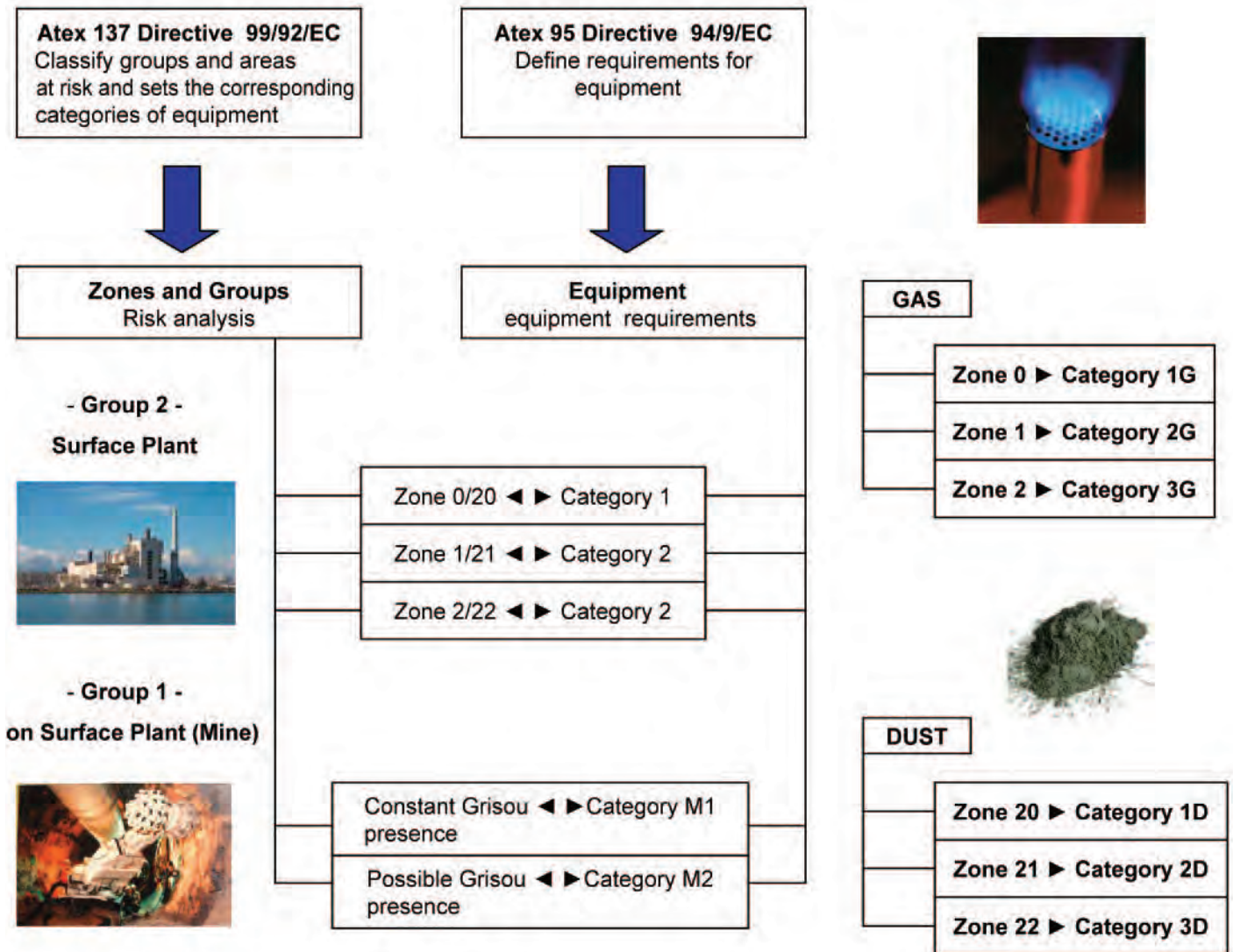
Occasional presence of explosive gases (G): zone 1

Occasional presence of explosive gases and/or combustible dust (D): Zone 21, during normal operation.

Zone 2 / 22 Danger lower

Improbable or only for a short time the presence of explosive gases (G): Zone 2

Improbable or only for a short time the presence of explosive gases and/or combustible dust (D) zone 22.





HYDRAULIC ACCUMULATORS

1.1



APPLICATION FIELDS

1.2



APPLICATIONS

1.3



CERTIFICATIONS

1.4



ELASTOMERS

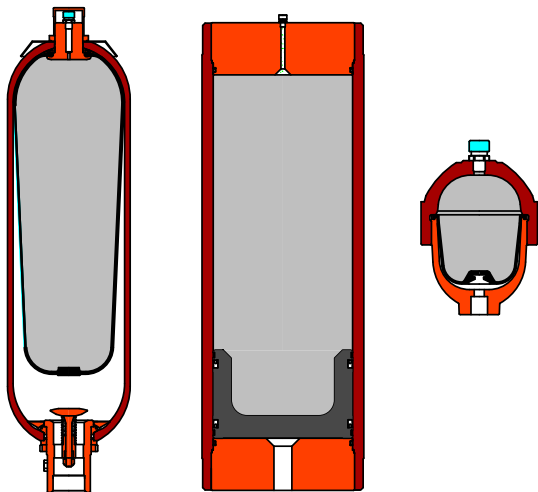
1.5

1.1.1 GENERAL

The main task of the hydraulic accumulator is to accumulate fluid under pressure and return it when necessary.

Since the accumulator contains a fluid under pressure, it is treated as a pressure tank and must therefore be sized for the maximum operating pressure according to test regulations in force in the country where it is installed.

To achieve the volume compensation and get the accumulation of energy, the fluid is pre-loaded by a weight, a spring or a compressed gas.



1.1a

Between the pressure of fluid and the counter-pressure exerted by the weight, the spring or the compressed gas must be in a constant state of equilibrium. Weight and spring accumulators are used in industry only in special cases and thus have a relative importance.

Gas accumulators without a separating element are rarely used in hydraulics due to the absorption of gas by the fluid.

In most of the hydraulic systems are then used the gas accumulators provided with a separating element between gas and fluid.

Depending on the type of separating element, we can distinguish bladder, piston and diaphragm accumulators.

1.1.2 TYPES OF ACCUMULATORS WITH SEPARATING ELEMENT

These accumulators consist of a fluid zone, a gas zone and a separating gas-tight element.

The fluid area is in contact with the circuit. With the pressure increases, a certain volume of fluid enters into the accumulator and compresses the gases.

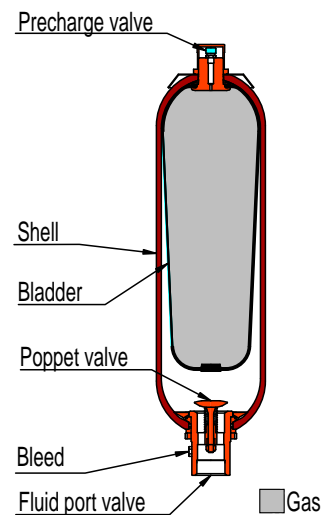
In the hydraulic systems, are used with the following accumulators with a separating element:

- bladder accumulators (Fig. 1.1b)
- piston accumulators (Fig. 1.1c)
- diaphragm accumulators (Fig. 1.1d)

1.1.2.1 BLADDER ACCUMULATORS

In the bladder accumulators, the fluid area is separated from the gas area by a flexible bladder. The fluid around the bladder is in contact with the circuit, so any increase in pressure causes the entry of the fluid into the accumulator and thereby compresses the gas. Vice versa, every drop of pressure in the circuit causes the expansion of the gas, resulting in delivery of the fluid from the accumulator to the circuit.

Bladder accumulators can be installed in vertical position (preferable), in horizontal one and, under certain operating conditions, also in an inclined one. In the inclined and vertical positions, the valve on the fluid side should face down. The bladder accumulators include a pressure welded or forged vessel, a flexible bladder and the fittings for gas and oil.

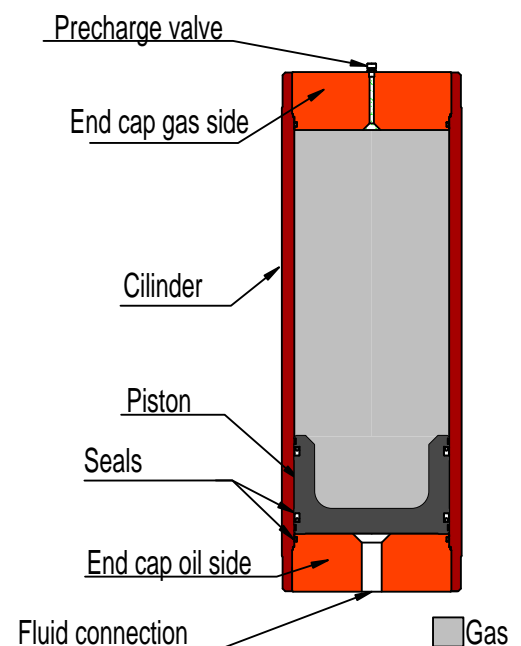


1.1b

1.1.2.2 PISTON ACCUMULATORS

In the piston accumulators, the fluid area is separated from the gas area from a metal piston fitted with gas tight seals. The gas area is filled with nitrogen.

The fluid zone is connected to the hydraulic system, so any increase



1.1c

in pressure in the circuit causes the entry of fluid in the accumulator resulting in compression of the gas.

Vice versa, at every drop of pressure in the circuit, the compressed gas contained in the accumulator expands and the accumulator delivers the fluid to circuit.

The piston accumulators can operate in any position, but it is preferable to mount them with the gas area upwards in order to prevent that solid contaminants contained in the fluid settle by gravity on the piston seals.

The typical structure of the piston accumulator, represented schematically in Figure 1.1c, includes a cylindrical pipe, a piston with seals, end caps in which there are the fluid side and gas side connections. The pipe serves to resist to the internal pressure and to drive the piston.

To ensure that the pressures of the two chambers are as balanced as possible, during the movement, it's necessary that the friction between the piston and the pipe is minimized.

For this reason, the inner surface of the pipe must be honed. In practice, however, the friction between the piston seals and the pipe creates, between gas area and fluid one, a pressure difference that, however, can be limited to 1 bar with appropriate selection of seals. The position of the piston can be shown continuously through a passing rod. By fixing a cam to the rod, you can also take advantage of the movement of the piston in order to control through limit switches the switching on or switching off of the pump.

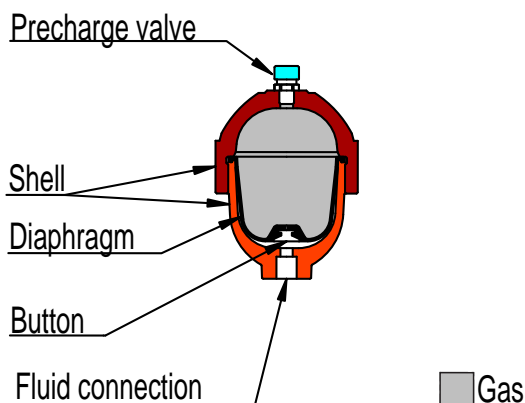
For other types of monitoring of the piston position, see Section 4.1.

1.1.2.3 DIAPHRAGM ACCUMULATORS

Diaphragm accumulators are made of a steel pressure-resistant vessel, usually cylindrical or spherical in shape, inside which is mounted a flexible material diaphragm as separating element.

Diaphragm accumulators are manufactured in three versions:

- screwed execution (see Section 5.1.)
- forged execution (see Section 5.2.)
- welded execution (see Section 5.3.)



In the screwed version, the diaphragm is blocked by a metal ring fitted between the lower shell and upper shell of the body.

In the welded accumulators, the diaphragm is pressed into the bottom before the welding of two steel shells.

Thanks to appropriate processes such as electron beam welding and also thanks to the special provision of the diaphragm, it's possible to prevent its damage and forging.

1.1.2.4 DERIVATION CONNECTION OF THE GAS BOTTLES

When for a given volume of fluid to provide/absorb the difference between the maximum and minimum pressure in the hydraulic circuit must be of limited size, the volume of the accumulator, obtainable with the calculation, may be very large. Under these conditions, it is preferable to connect the gas side of the accumulator with one or more additional gas bottles (Fig. 1.1l). For the sizing of the accumulator, you should take into account the following parameters:

- the useful volume to provide/absorb
- allowable ratios of pressures and volumes $P2/Po = V0/V2$
- the expansion of gas volume due to changes in operating temperature.

1.1.3 OPERATING CONDITIONS

Stage A

The accumulator is empty and neither gas nor hydraulic sides are pressurized $Po = P = 0$ bar

Stage B

The accumulator is pre-charged Po

Stage C

The hydraulic system is pressurized. System pressure exceeds the pre-charge one and the fluid flows into the accumulator $Po \rightarrow P1$

Stage D

System pressure peaks. The accumulator is filled with fluid according to its design capacity.

Any further increase in hydraulic pressure would be prevented by a relief valve fitted on the system $P1 \rightarrow P2$

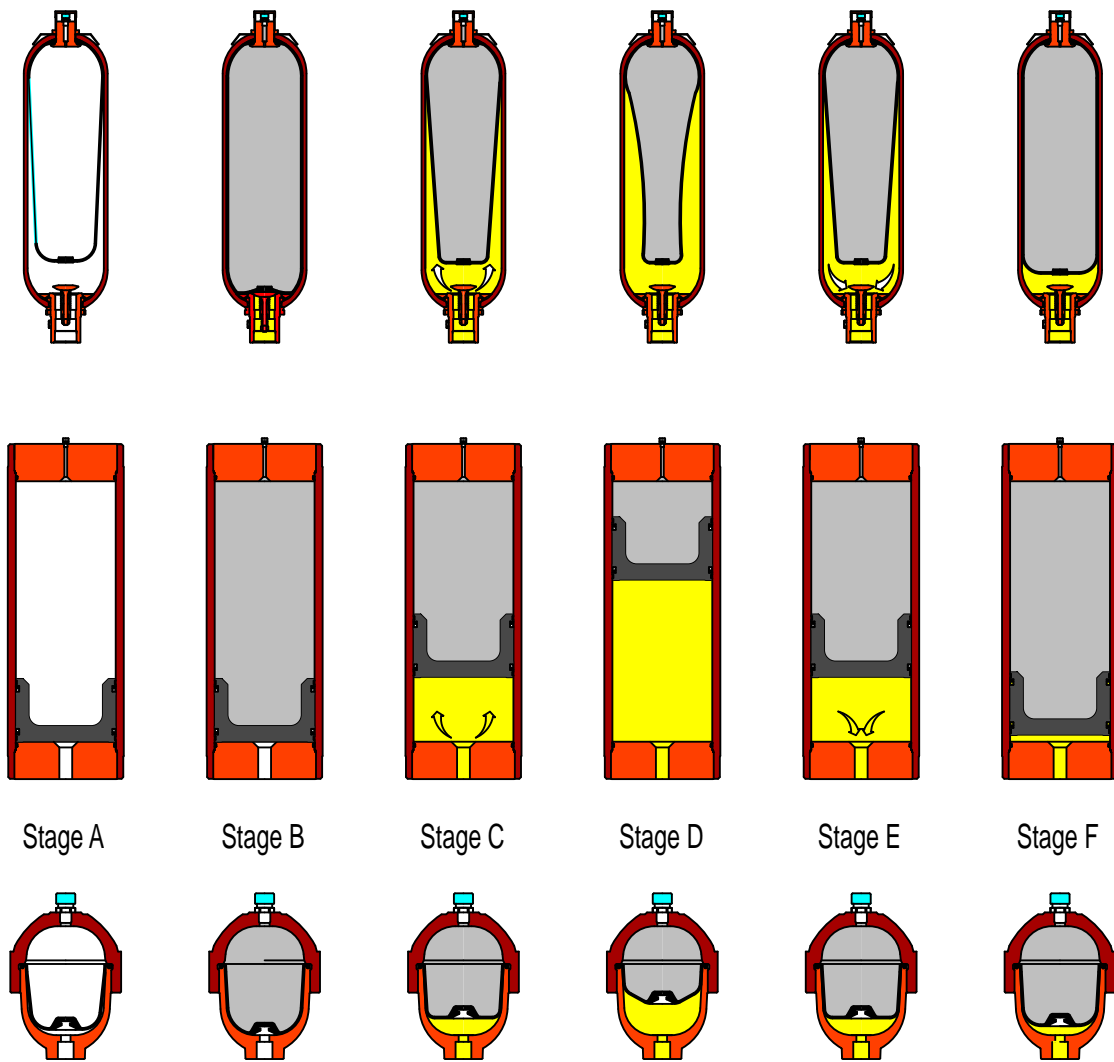
Stage E

System pressure falls. Pre-charge pressure forces the fluid from the accumulator into the system $P2 \rightarrow P1$

Stage F

Minimum system pressure is reached. The accumulator has discharged its maximum design volume of fluid back into the system $\min \Delta P (P1\min)$

1.1d



■ Gas

1.1e

1.1.4 ACCUMULATOR SELECTIONS

When selecting an accumulator for a particular application, both system and performance criteria should be taken into account. To ensure long and satisfactory service life, the following factors should be taken into account.

- failure modes
- flow rate
- response time
- high frequency cycling
- external forces
- output volume
- fluid type
- shock suppression
- sizing information
- temperature effect
- safety
- certification

1.1.4.1 FAILURE MODES

In certain applications, a sudden failure may be preferable than a gradual failure. A high-speed machine, for example, where product quality is a function of hydraulic system pressure.

As sudden failure is detected immediately, scrap is minimized, whereas a gradual failure might mean that production of a large quantity of sub-standard product could occur before the failure becomes apparent.

A bladder/diaphragm accumulator would be most suitable to this application. Vice versa, where continuous operation is paramount and sudden failure could be detrimental as, for example, in a braking or steering circuit on mobile equipment, a progressive failure mode is desirable. In this application, a piston accumulator would be appropriate.

1.1.4.2 FLOW RATE

Fig. 1.1.n shows typical maximum flow rates for Epe's accumulator styles in a range of sizes.

The larger standard bladder designs are limited to 1000 LPM, although this may be increased to 2000 LPM using a high-flow port.

The poppet valve controls the flow rate, with excessive flow causing the

poppet to close prematurely.
 Flow rates greater than 2000 LPM may be achieved by mounting several accumulators on a common manifold - see Accumulators station, Section 10.
 For a given system pressure, flow rates for piston accumulators generally exceed those of the bladder designs.
 Flow is limited by piston velocity, which should not exceed 3 m/sec. to avoid piston seal damage.
 In high-speed applications, high seal contact temperatures and rapid decompression of nitrogen, which has permeated the seal itself, can cause blisters, cracks and pits in the seal surface. In this type of application, a bladder style accumulator would be better suited.

1.1.4.3 RESPONSE TIME

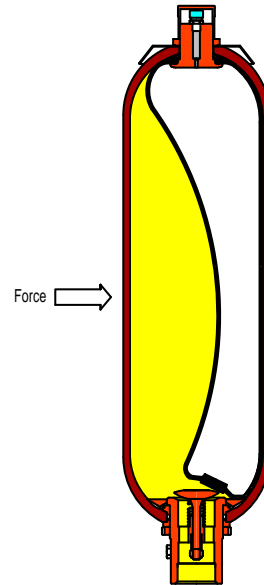
In theory, bladder and diaphragm accumulators should respond more quickly to system pressure variations than piston types.
 There is no static friction to be overcome as occurs with a piston seal, and there is no piston mass to be accelerated and decelerated.
 In practice, however, the difference in response is not great, and is probably insignificant in most applications.
 This applies equally in servo applications, as only a small percentage of servos requires response times of 25 ms or less.
 This is the point where the difference in response between piston and bladder accumulators becomes significant.
 Generally, a bladder accumulator should be used for applications requiring less than 25 ms response time, and either accumulator type for a response of 25 ms or greater.

1.1.4.4 HIGH FREQUENCY CYCLING

High-frequency system pressure cycling can cause a piston accumulator to “dither”, with the piston cycling rapidly back and forth so covering a distance less than its seal width.
 Over an extended period, this condition may cause heat build-up under the seal due to lack of lubrication, resulting in seal and bore wear.
 For high frequency dampening applications, therefore, a bladder/diaphragm accumulator is generally more suitable.

1.1.4.5 EXTERNAL FORCES

Any application subjecting an accumulator to acceleration, deceleration or centrifugal force may have a detrimental effect on its operation, and could cause damage to the bladder.
 Forces along the axis of the pipe or shell normally have little effect on a bladder accumulator but may cause a variation in gas pressure in a piston type accumulator because of the mass of the piston.
 Forces perpendicular to an accumulator’s axis should not affect a piston model, but fluid in a bladder accumulator may be thrown to one side of the shell (Fig. 1.1f), displacing the bladder and flattening and lengthening it. In this condition, fluid discharge could cause the poppet valve to pinch and cut the bladder.



1.1f
 Fig. 1.1f: Perpendicular force causes the mass of the fluid to displace the bladder. Higher pre-charge pressures increase the resistance of the bladder according to the effects of the perpendicular forces.

1.1.4.6 OUTPUT VOLUME

The maximum sizes available of each type of accumulator determine the limits of suitability where large output volumes are required. There are, however, several methods to achieve higher output volumes than standard accumulator capacities suggest - see Accumulators station, Section 10.

Compression ratio	System pressure bar		Recommended Precharge bar		Fluid Output LPM	
	max	min	Bladder	Piston	Bladder	Piston
1,5	210	140	125	130	10,5	11,5
2	210	105	95	98	16	16,5
3	210	70	60	60	21,5	21,5
6	210	35	*	28	*	24

* Below required minimum operating ratio of 4:1

1.1g
 Fig. 1.1g compares typical fluid outputs for Epe’s 35 litres piston and bladder accumulators operating isothermally as auxiliary power sources over a range of minimum system pressures.
 The higher pre-charge pressures recommended for piston accumulators result in higher outputs than as occurred in comparable bladder accumulators.

In addition, bladder accumulators are not generally suitable for compression ratios greater than 1:4, as these could result in excessive bladder deformation.

Piston accumulators have an inherently higher output relative to their overall dimensions, which may be critical in locations where space is limited.

Piston accumulators are available in a choice of diameters and lengths for a given capacity, whereas bladder and diaphragm accumulators are frequently offered in only one size per capacity, and fewer sizes are available.

Piston accumulators can also be built to custom lengths for applications in which the available space is critical

1.1.4.7 FLUID TYPE

Bladder/Diaphragm accumulators are more resistant to damage caused by contamination of the hydraulic fluid than piston types.

While some risks exist from contaminants trapped between the bladder and the shell, a higher risk of failure exists from the same contaminants acting on the piston seal.

Bladder accumulators are usually preferred to piston type accumulators for water service applications.

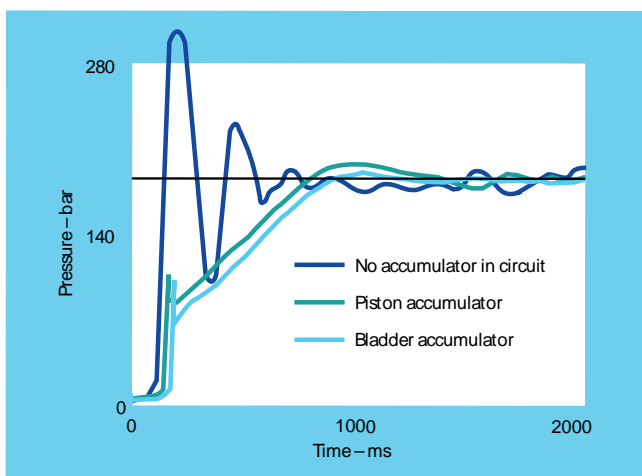
Water systems tend to carry more solid contaminants and lubrication is poor.

Both the piston and bladder type units require some type of preparation to resist to corrosion on the wetted surfaces (example nickel coated) Piston accumulators are preferred for systems using special fluids or where extreme temperatures are experienced as compared to bladders.

Piston seals are more easily moulded in the required special compounds and may be less expensive.

1.1.4.8 SHOCK SUPPRESSION

Shock control does not necessarily demand a bladder/diaphragm accumulator, it is possible to use also a piston accumulator, see example Fig. 1.1h



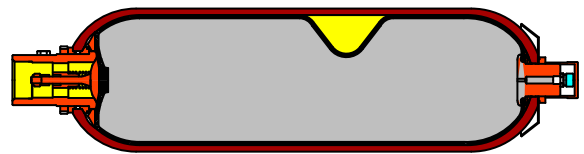
1.1h

1.1.4.9 MOUNTING POSITION

The optimum mounting position for any accumulator is vertical, with the hydraulic port downwards. Piston models can be mounted horizontally if the fluid is kept clean but, if solid contaminants are present or expected in significant amount; horizontal mounting can result in uneven or accelerated seal wear.

A bladder accumulator may also be mounted horizontally, but uneven wear on the top of the bladder as it rubs against the shell while floating on the fluid can reduce its service life and even cause permanent distortion.

The extent of the damage will depend on the fluid cleanliness, cycle rate, and compression ratio. In extreme cases, fluid can be trapped away from the hydraulic port (Fig. 1.1i),



1.1i

Fig. 1.1i A horizontally-mounted bladder accumulator can trap fluid away from the hydraulic valve reducing output, or the bladder may become elongated, forcing the poppet valve to close prematurely.

1.1.4.10 SIZING INFORMATION

Accurate sizing of an accumulator is critical if it has to deliver a long and reliable service life. Information and worked examples are shown in Section 2 or accumulator size can be calculated automatically by entering application details into Epe's Sizing software selection program.

Please contact your local Epe distributor for details or contact us at www.epeitaliana.it

1.1.4.11 TEMPERATURE EFFECT

Temperature variation can seriously affect the pre-charge pressure of an accumulator. As the temperature increases, the pre-charge pressure increases; Vice versa, decreasing temperature will decrease the pre-charge pressure. In order to assure the accuracy of your accumulator pre-charge pressure, you need to factor in the temperature variation.

The temperature variation is determined by the temperature encountered during the pre-charge versus the operating temperature expected in the system, (see Section 2.2.)

1.1.4.12 SAFETY

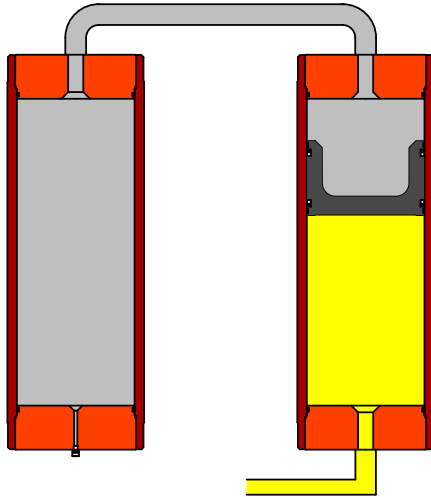
Hydro-pneumatic accumulators should always be used in conjunction with a safety block, to enable the accumulator to be isolated from the circuit in an emergency or for maintenance purposes, (see Section 8 e 9).

1.1.4.13 CERTIFICATION

Accumulators are frequently required to conform to national or international certification. These requirements range from simple design factors to elaborate materials testing and inspection procedures carried out by an external agency. Most of the accumulators within Epe's piston, bladder or diaphragm ranges are available with certification PED97/23EC or other on request (see Section 1.4)

1.1.5 GAS BOTTLES INSTALLATION

Remote gas storage offers installation flexibility where the available space or position cannot accommodate an accumulator of the required size. A smaller accumulator may be used in conjunction with an Epe additional gas bottle, which can be located elsewhere (Fig. 1.1l)



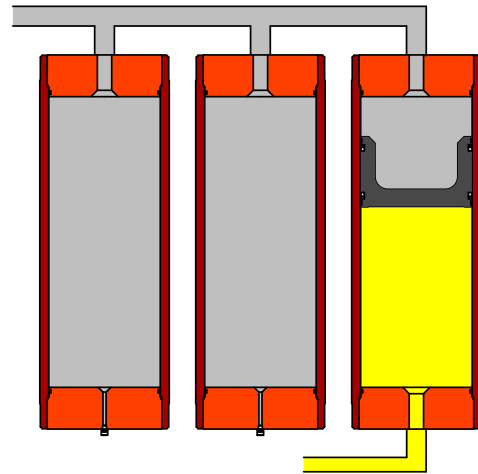
1.1l

Fig. 1.1l Piston accumulator with additional bottles type AB.

The gas cylinder and the accumulator must be sized by Section 2: Gas bottle installations may use either bladder or piston accumulators, subject to the following considerations.

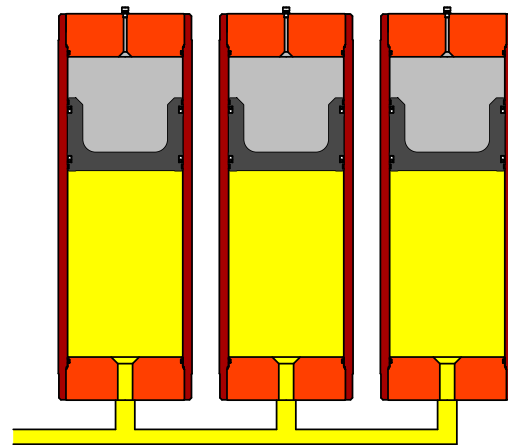
- Any accumulator used with remote gas storage should generally have the same size port of the gas end as at the hydraulic end, to allow an unimpeded flow of gas to and from the gas bottle. The gas bottle will have an equivalent port in one end and a gas charging valve at the other.
- A piston accumulator should be carefully sized to prevent the piston bottoming at the end of the cycle. Bladder designs should be sized to prevent filling of more than 75% full.
- Bladder installations require a special device called transfer barrier at the gas end, to prevent extrusion of the bladder into the gas bottle piping. The flow rate between the bladder transfer barrier and its gas bottle will be restricted by the neck of the transfer barrier tube.
- Because of the above limitations, piston accumulators are generally preferred to bladder types for use in gas bottle installations.
- Diaphragm style accumulators are normally not used in conjunction with gas bottles.

The requirement for an accumulator with an output of more than 200 litres cannot usually be met by a single accumulator, because larger piston designs are relatively rare and expensive, and bladder designs are not generally available in these sizes. The requirement can, however, be met using one of the multiple-component installations shown in Figs. 1.1m and 1.1n.



1.1m

Fig. 1.1m (above) Several gas bottles can supply pre-charge pressure to a single accumulator



1.1n

Fig. 1.1n (above) Multiple accumulators connected together offer high system flow rates

The installation in Fig. 1.1m consists of several gas bottles serving a single piston accumulator through a gas manifold. The accumulator portion may be sized outside of the limitations of the sizing formula on Section 2.2, but should not allow the piston to strike the caps repeatedly while cycling. The larger gas volume available with this configuration allows a relatively greater piston movement – and hence fluid output – than with a conventionally sized single accumulator. A further advantage is that, because of the large pre-charge “reservoir”, gas pressure is relatively constant over the full discharge cycle of the accumulator. The major disadvantage of this arrangement is that a single seal failure could drain the whole gas system. The installation in Fig. 1.1n uses several accumulators, of piston or bladder design, mounted on a hydraulic manifold. Two advantages of multiple accumulators over multiple gas bottles are that higher unit fluid flow rates are permissible, and a single leak will not drain pre-charge pressure from the entire system.

A potential disadvantage is that, where piston accumulators are used, the piston with the least friction will move first and could occasionally bottom on the hydraulic end cap. However, in a slow or infrequently used system, this would be of little significance.

1.1.6 FAILURE PREVENTION

Accumulator failure is generally defined as inability to accept and exhaust a specified amount of fluid when operating over a specific system pressure range.

Failure often results from an unwanted loss or gain of pre-charge pressure.

It cannot be too highly stressed that the correct pre-charge pressure is the most important factor in prolonging accumulator life.

If maintenance of the pre-charge pressure and relief valve settings are neglected, and if system pressures are adjusted without making corresponding adjustments to pre-charge pressures, shortened service life will result.

1.1.6.1 FAILURE

Bladder/diaphragm accumulator failure occurs rapidly due to bladder/diaphragm rupture (Fig. 1.1o). Rupture cannot be predicted because the intact bladder or diaphragm is essentially impervious to gas or fluid seepage; no measurable gas or fluid leakage through the bladder or diaphragm precedes failure.

1.1.6.2 PISTON ACCUMULATOR FAILURE

Piston Accumulator failure generally occurs in one of the following gradual modes.

- FLUID LEAKS TO THE GAS SIDE

This failure, sometimes called dynamic transfer, normally takes place during rapid cycling operations after considerable time in service. The worn piston seal carries a small amount of fluid into the gas side during each stroke.

As the gas side slowly fills with fluid, pre-charge pressure rises and the accumulator stores and exhausts decreasing the amounts of fluid. The accumulator will totally fail when pre-charge pressure equals the maximum hydraulic system pressure. At that point, the accumulator will accept no further fluid. As the increase in pre-charge pressure can be measured (Fig. 1.1oa), failure can be predicted and repairs can be carried out before total failure occurs.

- GAS LEAKAGE

Pre-charge may be lost as gas slowly bypasses the damaged piston seals. Seal deterioration occurs due to excessively long service, fluid contamination or a combination of the two. Gas can also vent directly through a defective gas core or an end cap O-ring.

The reducing pre-charge pressure then forces progressively less fluid into the system. As this gradual decrease in pre-charge pressure can be measured (Fig. 1.1ob), repairs can again be carried out before total failure occurs.

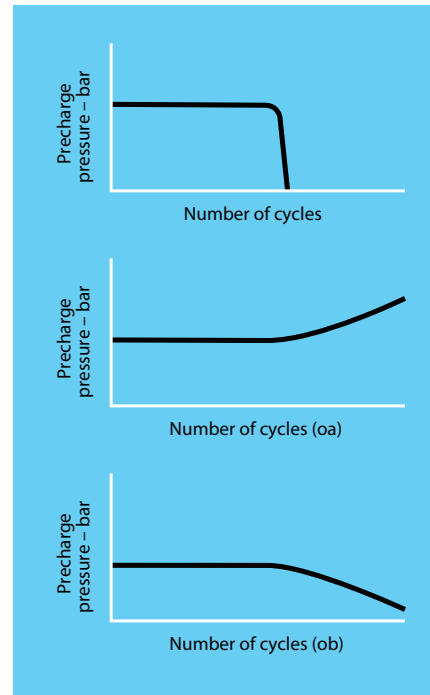


Fig. 1.1.o When an accumulator bladder ruptures, precharge pressure immediately falls to zero

As fluid leaks past an accumulator piston, precharge pressure rises (oa).

Gas leaking past the piston or valve causes precharge pressure to fall (ob)

1.1o

1.1.7 PRE-CHARGING PROCESS

Correct pre-charging involves accurately filling of the gas side of an accumulator with a dry, inert gas such as nitrogen, before admitting fluid to the hydraulic side.

It is important to pre-charge an accumulator under the correct specified pressure. Pre-charge pressure determines the volume of fluid retained in the accumulator at minimum system pressure. In an energy storage application, a bladder/ diaphragm accumulator is typically pre-charged to 90% of the minimum system pressure, and a piston accumulator to 97% of the minimum system pressure at the system operating temperature.

The ability to correctly carry out and maintain pre-charging is an important factor when choosing the type of accumulator for an application. Bladder accumulators are more susceptible to damage during pre-charging than piston types. Before pre-charging and entering in service, the inside of the shell should be lubricated with system fluid.

This fluid acts as a cushion and lubricates and protects the bladder as it expands. When pre-charging, the first 10 bar of nitrogen should be introduced slowly. Failure to follow this precaution could result in immediate bladder failure: high pressure nitrogen, expanding rapidly and thus cold, could form a channel in the folded bladder, concentrating at the bottom. The chilled expanding rapidly brittle rubber would then inevitably cause the rupture (Fig. 1.1p).

The bladder could also be forced under the poppet, resulting in a cut. (Fig. 1.1q).

Close attention should be paid to operating temperature during pre-charging, as an increase in temperature will cause a corresponding increase in pressure which could then exceed the pre-charge limit.

Little damage can occur when pre-charging or checking the pre-charge on a piston accumulator, but care should be taken to make sure the accumulator is void of all fluid to prevent getting an incorrect reading on the pre-charge.

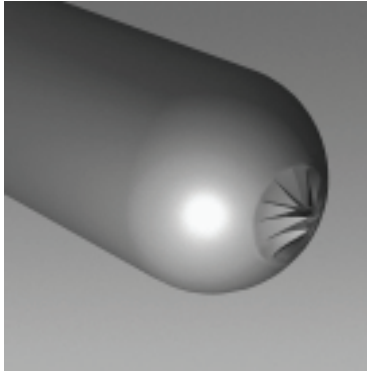


Fig. 1.1p Starburst rupture caused by loss of bladder elasticity

1.1p

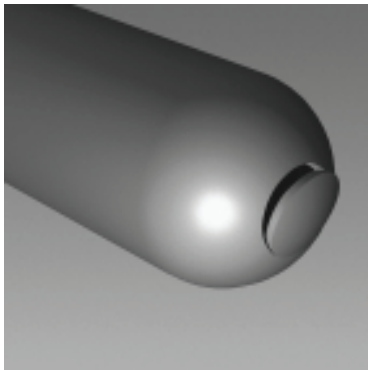
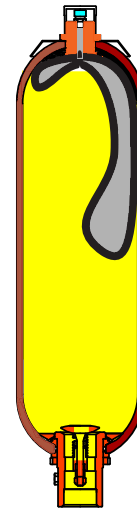


Fig. 1.1q C-shaped cut shows that bladder has been trapped under poppet

1.1q



1.1r

EXCESSIVELY LOW PRE-CHARGE

Excessively low pre-charge pressure or an increase in system pressure without a corresponding increase in pre-charge pressure can also cause operating problems and subsequent accumulator damage. With no pre-charge in a piston accumulator, the piston will be driven into the gas end cap and will often remain there. Usually, a single contact will not cause any damage, but repeated impacts will eventually damage the piston and seal.

Vice versa, for a bladder accumulator, too low or no pre-charge can have rapid and severe consequences. The bladder will be crushed into the top of the shell and can extrude into the gas stem and be punctured (Fig 1.1r). This condition is known as “pick out”. One cycle as the one mentioned above is sufficient to destroy a bladder.

Overall, piston accumulators are generally more tolerant with respect to careless pre-charging.

EXCESSIVELY HIGH PRE-CHARGE

Excessive pre-charge pressure or a decrease in the minimum system pressure without a corresponding reduction in pre-charge pressure may cause operating problems or damage to accumulators.

With excessive pre-charge pressure, a piston accumulator will cycle between stages (e) and (b) of Fig. 1.1e), and the piston will travel too close to the hydraulic end cap. The piston could bottom at minimum system pressure, thus reducing the output and eventually damaging the piston and the piston seal. The piston can often be heard bottoming, warning of impending problems.

An excessive pre-charge in a bladder accumulator can drive the bladder into the poppet assembly when cycling between stages (e) and (b). This could cause fatigue failure of the poppet spring assembly, or even a pinched and cut bladder, should it become trapped beneath the poppet as it is forced closed (Fig. 1.1q). Excessive pre-charge pressure is the most common cause of bladder failure.

Reproduction is forbidden.

In the spirit of continuous improvement, our products may be changed.

1.3.1 GENERAL

It is not possible to design an optimum hydraulic system in economic and technical point of view that does not involve the use of hydropneumatic accumulators. From an economic point of view, the use of hydropneumatic accumulators usually leads to a reduction in equipment and operating costs (energy savings) and dimensions of the plant. From a technical point of view, the use of an accumulator may become relevant or appropriate to carry out certain functions, such as increase reliability, improve overall efficiency, extend the lives of the plant components and eliminate secondary phenomena (noise, development of heat).

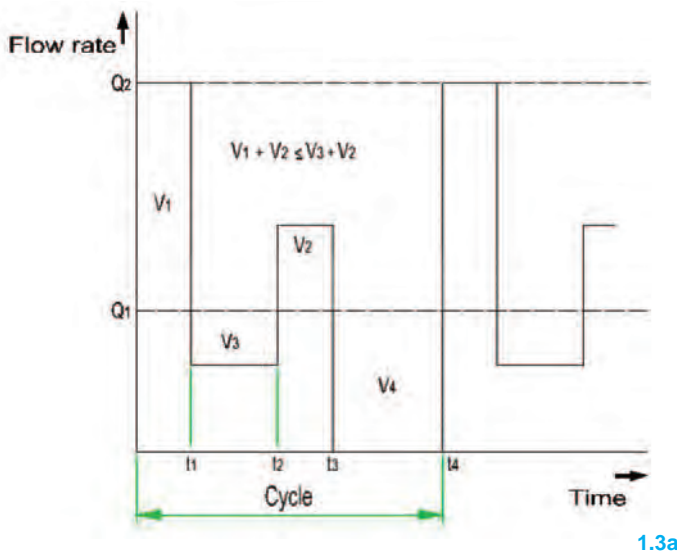
The hydropneumatic accumulators used in order to: save on the pump power to be installed in the case of variable demand for oil, supply power in emergency situations or during working stages requiring a high power even for short periods, shorter the working cycles, drive the secondary circuits as volume compensators when there are variations of pressure and temperature, maintain the pressure in the closed circuits, compensate for the losses, recover the braking energy, as a tank of fluid under pressure, separate the fluids, such as replacement of springs and damper for shocks and pulsations absorbing. Here below, we describe some applications in more detail.

1.3.2 ACCUMULATION OF ENERGY

The graph (cyclograph) of the power required by a plastic injection machine shown in Chart 1.3a shows that, with a high rate of injection into the mould, the maximum power is required only for a short time. Without a compensation system, the pump should be sized for peak power, even if requested for a few moments.

Once used an accumulator, the power (and thus the flow rate) of the pump can be instead fixed according to the average absorption.

In the early stages of the working cycle when the needs of system flow rate is less than the pump one, this fills the accumulator. When you need the maximum flow rate, the difference in comparison with the pump supply is taken from the accumulator.



Advantages:

- use of lower capacity pumps
- lower installed power
- less heat generation
- easy maintenance and installation

- for certain applications: damping the peaks and pressure pulses, with consequent longer life time of the components.

The installation of hydropneumatic accumulators allows substantially saving energy.

For the systems with very strong instantaneous or short-term absorptions or short operating cycles, the only economic solution is represented by the hydropneumatic accumulators.

1.3.2.1 MORE USERS WITH DIFFERENT ABSORPTION

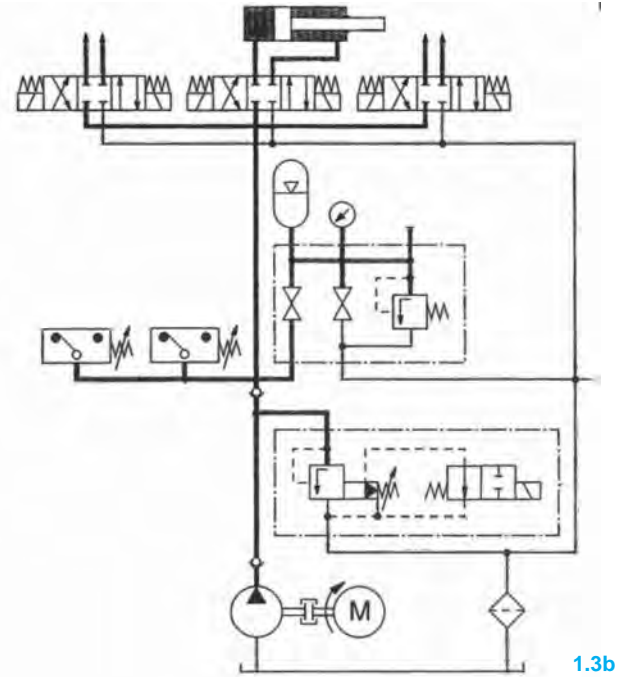


Fig. 1.3b: circuit diagram for the accumulation of energy of a plastic injection machine

1.3.2.2 REDUCTION OF THE TIMES OF THE WORKING CYCLES (EXAMPLE, TOOL MACHINES)

Thanks to the hydropneumatic mounting directly next to the user, the inertia of the fluid column is exceeded more quickly than if all the fluid must be set in motion by the pump.

So you get a faster start-up and also the accumulators compensate the instantaneous differential absorptions of the single users.

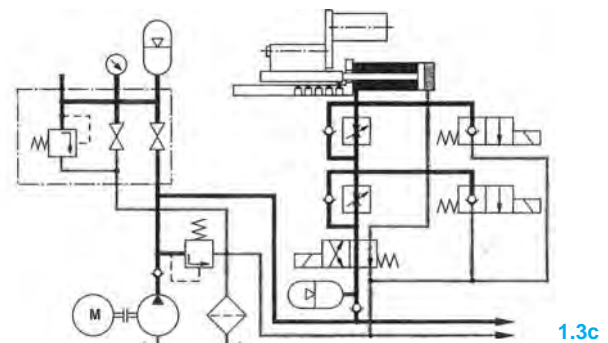


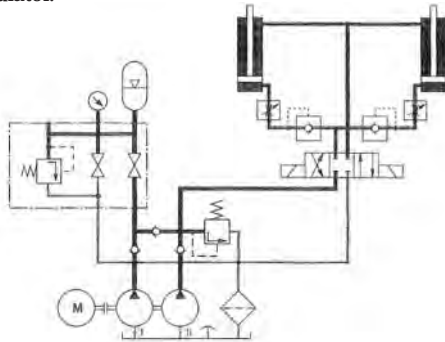
Fig. 1.3c: circuit diagram for the accumulation of energy of a tool machine.

1.3.2.3 REDUCTION OF THE APPROACH TIMES

The rational performance of the pressing and printing cycles demands for rapid empty strokes in order to make more time available for the phase of work under high pressure.

During progressing under empty, the fluid is simultaneously delivered by the low pressure pump, the high pressure pump and the accumulator, so as to achieve high speed.

At the end of the approach stroke, the pressure increases, the check valve closes and only the high pressure pump delivers to the activator a reduced flow rate but at high pressure, while the low pressure pump charges the accumulator.



1.3d

Fig. 1.3d: circuit diagram for the reduction of the approach time of a press.

1.3.3 RESERVE OF FLUID (SAFETY)

Using the accumulator as a safety device in normal operation of the system, it does not act as an energy source, although it is always connected to the pump.

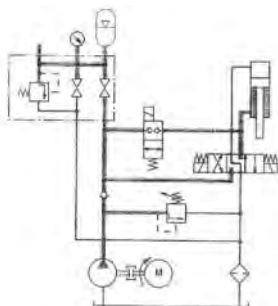
If the accumulator is equipped with a high quality separating element, the accumulated energy can be stored almost indefinitely and is always available when needed.

Safety devices on the accumulators are used for emergency operation on the hydraulic plants, to ensure the performance of certain functions in the event of failure, such as:

- closure of bulkheads, valves, exchanges
- switching on of gate valves
- switching on of power switches
- start-up of rapid switching off systems

1.3.3.1 EMERGENCY DRIVE

In an emergency, for example due to power failure, the presence of an accumulator allows carrying out one or more output and/or return strokes. Fig. 1.3e shows the circuit diagram of an emergency drive: in case of power failure, the spring returns the valve to its resting position, making the connection between the accumulator and rod side chamber with a consequent return of the cylinder.



1.3e

Fig. 1.3e: circuit diagram of an emergency drive.

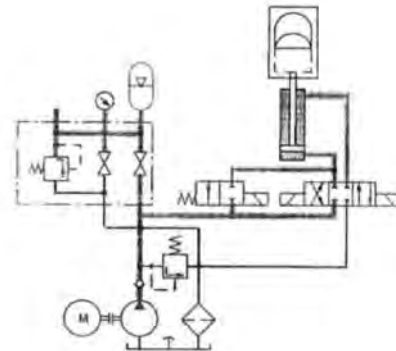
Another case of emergency drive based on the accumulator is the completion of a working cycle already begun, despite the failure of a pump or a valve.

Advantages of the emergency drive with accumulator:

- immediate availability of stored energy
- indefinite energy conservation
- no operator fatigue
- immediate response
- maximum security with low maintenance.

High short-term oil absorption during failure

With the circuit of Figure 1.3f, the output of the cylinder, in case of pump failure, is guaranteed by the accumulator.



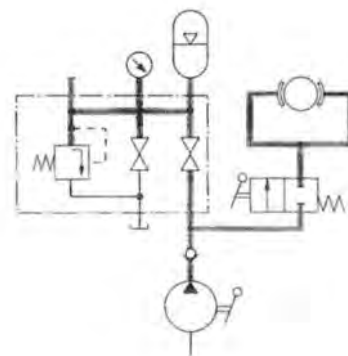
1.3f

Fig. 1.3f: output of the cylinder in case of damage to the pump.

1.3.3.2 EMERGENCY BRAKING

The hydraulic accumulator is used to operate the emergency drive of the brake and the doors of funicular railways, cableways, special vehicles etc. The accumulators charge (closed circuit) is performed with a motor pump in proper workshop or with a pump.

Often the emergency brake circuit is passive: in case of failure, the braking is automatic by effect of a spring, while in normal conditions the brake cylinders are kept open by the pressure of the accumulator that operates contrary to the spring.



1.3g

Fig. 1.3g: emergency brake for cableway

1.3.3.3 EMERGENCY LUBRICATION

To maintain intact the lubricating film in the bearings, they must be constantly fed with oil, so the lubrication points should always be under pressure. In case of failure of the lubricant pump, the presence of an accumulator keeps the pressure up until the stop of the machine or until any auxiliary lubrication pump restore the required pressure.

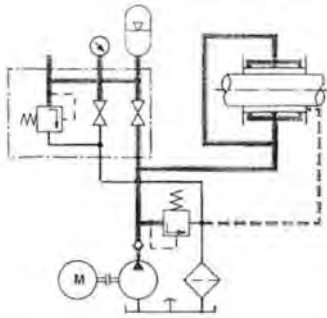
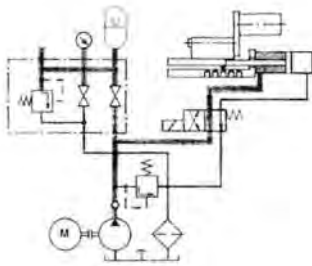


Fig. 1.3h: emergency lubrication for bearings.

1.3h

1.3.3.4 OPERATING SECURITY

The lack of voltage during the operation of a machine may cause costly business interruptions. The accumulators allow the completing of the production cycle started.



1.3i

Fig. 1.3i: operational safety circuit.

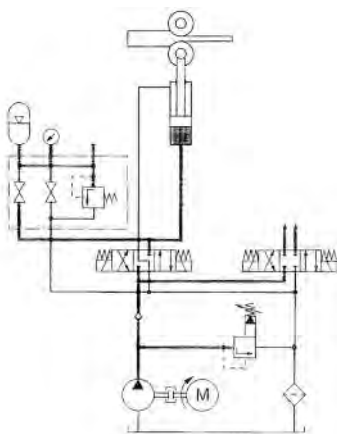
1.3.4 FORCES COMPENSATOR

With the accumulators forces or movements can be compensated. This need arises when, during a continuous working process, i.e. rolling, may occur obliquely positioning of the forming rolls as a result of variables resistances by the material to be laminated. Thanks to the balance of the rolls, you get a uniform thickness.

Fig. 1.3l shows the circuit diagram for the balance of the rolls of a rolling mill, comprising an accumulator with its safety block.

Advantages:

- mild compensation of the forces and, therefore, less load on the foundation and frame
- savings of counter weights and thus reduction in weight and dimensions of the plant



1.3l

Fig. 1.3l: balance of the rollers of a rolls mill

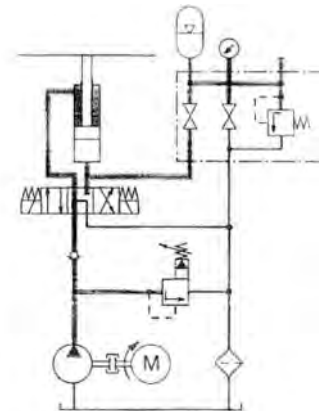
1.3.5 COMPENSATION OF LEAKAGES

The compression force exerted by a hydraulic cylinder can only be maintained by compensating the inevitable losses due to system leakage.

The accumulators are particularly suitable for this purpose. Fig. 1.3m shows a scheme of a system of compensation for a leak, through which, when the pump is stopped, the leakage losses are replenished by dispensing oil from the accumulator to the piston side chamber of the cylinder. The pump starts only when the pressure falls below a predetermined value and charges the accumulator.

Advantages:

- intermittent pump operation
- less heat generation, resulting in lower operating costs
- longer life of the plant.



1.3m

Fig. 1.3m: leak compensation

1.3.6 CUSHIONING

In the hydraulic systems, pressure oscillations can occur when the flow conditions vary for reasons related to the operation of the system; i.e.

- uneven distribution of the pump
- presence of systems including masses and resilience (i.e. valves pressure balancing device) or instantaneous connection of circuit branches at different pressures
- switching on of regulation and interception valves with short opening and closing
- switching on or off of pumps.

These phenomena can cause variations in flow rate or pressure, which may have adverse effects on the life of components.

According to the conditions of formation, the pressure oscillations can be divided into impulsive (pressure peaks) and periodic (pulses).

To prevent that the functioning of the system is compromised, you should evaluate, already during the design phase, the amplitude of these oscillations and provide appropriate measures of damping.

While there are several options to reduce the pressure fluctuations, in hydraulic systems are particularly suitable certain types of accumulators. To meet the requirements of the machines in terms of performance and speed of the cycles, while ensuring a limited noise, it is advisable to install an accumulator with appropriate features as a shock absorber in order to:

- reduce the flow rate fluctuations caused by the operation of the machine and their transmission to the mechanical structures that act as resonant bodies and convert them to noise
- extend the life of the machine.

1.3.6.1 FLOW RATE FLUCTUATIONS OF PUMPS

The volumetric pumps produce more or less pronounced flow rate pulsations, causing noise and vibrations, with danger of damage to the plant. An accumulator mounted near the pump reduces this phenomenon.

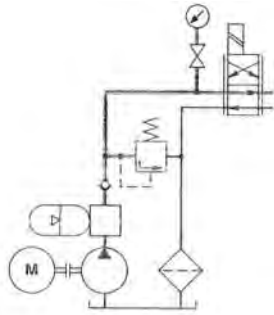


Fig 1.3n Damping pulsations caused by the volumetric pumps.

1.3n

1.3.6.2 DAMPING OF PRESSURE WAVES

In most of the hydraulic plants, pressure waves are generated by various components or by the effect of load changes in the system, for example when using the bucket of an excavator. The installation of an accumulator protects the sensitive components from pressure waves and, in particular, the pumps.

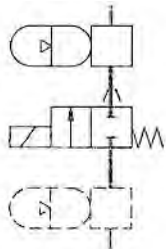
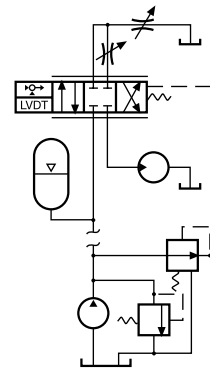


Fig. 1.3o: dampening the pulsations downwards the pump

1.3.6.3 FAST OPENING AND CLOSING OF THE VALVES

By discharging instantly a strong flow rate in the return line generate water hammer, which can damage the heat exchangers and the filters on the return lines.

But even when the fluid in motion is stopped suddenly (i.e. due to an emergency stop), the water hammer can damage the valves, pipes and fittings.



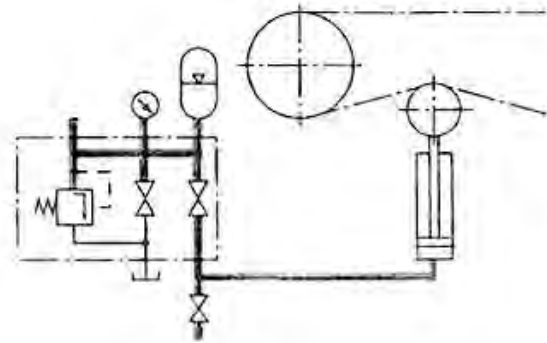
1.3p

Fig. 1.3p: damping the water hammer.

1.3.6.4 HYDRAULIC SPRING

For the damping of shock waves and pressure fluctuations, the accumulator acts as a hydraulic spring thanks to the compressible gas it contains.

The first example below for the application of the "hydraulic spring" is the hydraulic tensioning device of a chain (Fig. 1.3q).



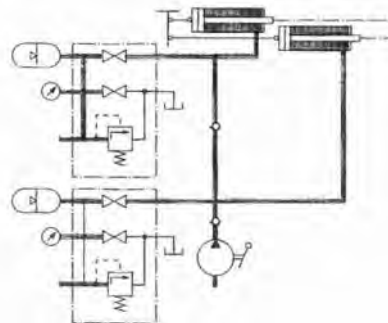
1.3q

Fig. 1.3q: tensioning of a chain for a tool machine.

1.3o

By installing an accumulator to stretch the chain of a tool machine or a vehicle, you avoid tearing chain transmission to the system.

The second application example of the "hydraulic spring" is the tensioning of the hauling cables and main ones (Fig. 1.3r).



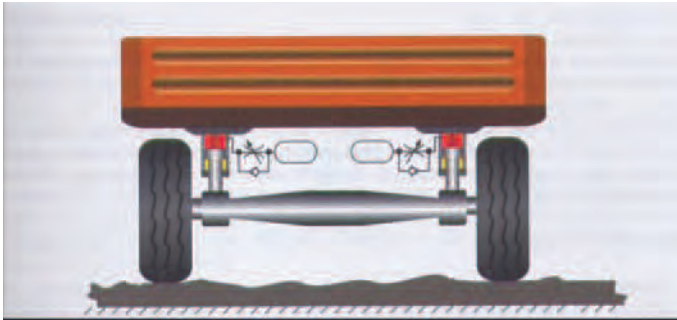
1.3r

Fig. 1.3r: tensioning of the supporting cables of a cableway.

The third application example of the "hydraulic spring" is the cushioning system for vehicles (fig. 1.3s).

It's known that for the smooth operation of the cableways and elevators, small tolerances are required on cable lengths.

The differences in length of the cables caused, in case of cableways, by the strokes up and down and in the case of elevators by the temperature variations or by the inequalities of the loads are compensated by inserting one or more accumulators in the hydraulic circuit.



1.3s

Fig. 1.3s: suspension system for vehicles

Marching on irregular road surfaces, a vehicle is affected by mechanical stresses, potentially harmful for the body and the chassis.

By installing a hydropneumatic suspension system comprising some cylinders connected to an accumulator, the mechanical stresses are first converted into hydraulic stresses in the cylinders and then are absorbed by the accumulator.

The use of in-vehicle hydropneumatic suspensions:

- reduces the risk of accidents
- extends the life of the vehicle
- allows faster cornering
- keeps the load in the desired position
- reduces stress on material
- reduces the operating costs

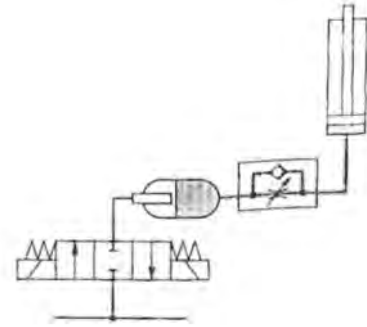
1.3.7 SEPARATION OF FLUIDS

In fluid power systems in which there are two fluids that must interact while remaining strictly separated, as separating element, it is used a bladder or a diaphragm accumulator.

1.3.7.1 SEPARATION BETWEEN AIR AND OIL

In some pneumatic systems, it can be useful to add a hydraulic component when it is required the generation of a high force.

The separation between the pneumatic circuit and hydraulic one is obtained with an accumulator. As in this application the fluid power comes from the pneumatic circuit, the hydraulic circuit does not require a power unit.



1.3t

Fig. 1.3t: accumulator used for the separation of a pneumatic circuit from a hydraulic one.

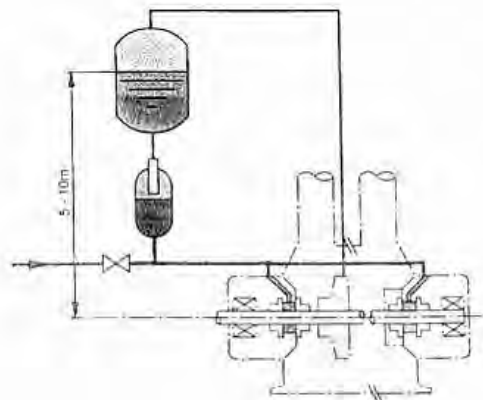
1.3.7.2 SEPARATION OF TWO FLUIDS

In compressors for petrochemical use with floating ring seals, for operational and pollution reasons, the process gas pumped by the compressor should not come into contact with the flushing fluid of the seals.

On the other hand, the operation of this type of seal requires a flushing pressure greater than 0.5 – 1.0 bar with respect to the process gas.

To ensure the overpressure, a tank containing a liquid is installed in an elevated position with respect to the compressor (Fig. 1.3u,) on the surface of which acts the same process gas supplied by the compressor.

To avoid contamination of the process gas, the fluid should have a neutral behaviour with regard to the gas. But, as normally it does not have the lubricity that the floating seals and shaft bearings require, to the seals must be sent a different fluid than the one contained in the tank. The separation between the two fluids is achieved with an accumulator.

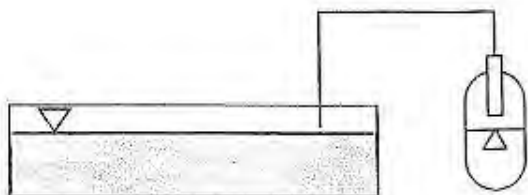


1.3u

Fig. 1.3u: accumulator for the separation of the fluids.

1.3.7.2 SEPARATION OF TWO GASES

In systems that can be damaged by the infiltration of moisture through the tank breather filter, or in the case of pressurized tanks with nitrogen to prevent condensation due to temperature changes, compensation in volume changes is provided by an accumulator (Fig. 1.3v).



1.3v

Fig. 1.3v: accumulator for the volume compensation.

Reproduction is forbidden.

In the spirit of continuous improvement, our products may be changed.

1.4 DESCRIPTION

Accumulators are pressure vessels subjected to the specific current regulations or accepted ones of the Countries where they will be installed.

For all the European Countries, design, construction and accumulator testing must be carried out according to the Directive 97/23/EC on Pressure Equipment.

EPE ITALIANA, also in virtue of the quality system using EN ISO 9001:2000, works according to forms H and H1 of total quality guarantee and design control issued by the Notify Body.

The above mentioned Directive includes the pressure equipment that exceeds 0.5 bar. So all the accumulators are involved in this Directive even if it provides different procedures of testing and certification.

Please keep in mind that accumulators up to 1 litre of volume, even if manufactured according to the Directive 97/23/EC, are not marked EC and are not provided with the conformity declaration.

For volumes higher than 1 litre, after the testing, each accumulator is stamped with the mark CE followed by the number that identifies the Notify Body.

For these high pressure and low pressure accumulators, the documentation necessary includes the conformity declaration and the operator's manual.

It is also possible to supply accumulators in accordance with Directive ATEX 94/9/EC (enclosure VIII) and with harmonized regulations EN 13463-1 related to non-electrical equipment to be used in environment with potentially explosive atmosphere and to be included into the classification ATEX EC II2GcT4.

EPE ITALIANA provides also other tests and certifications for those Countries in which EC regulations are not accepted:

- ASME-U.S. for USA, Canada, South Africa, etc..
- ML (ex SQL) for China.
- Australian Pressure Vessel Standard AS1210-1997 for Australia.
- GOST for Russia.
- RTN - Rostekhnadzor for Ukraine
- DDP passport for Algeria
- RINA and in some cases BS-L Lloyd's Register and Germanischer Lloyd for naval construction.
- For other Countries, which require a specific test, accumulators are in any case manufactured according to the European Directive but are supplied without EC marking and with factory test only.

The documentation related to each regulation is normally provided in a proper envelope along with the goods. If it's not available, it will be sent by post or in another way as soon as possible.

In order to define correctly both the price and the availability, it is necessary that in the inquiry it is mentioned the required certification.

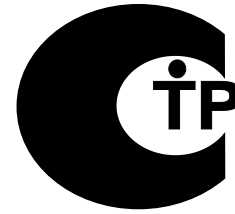
1.4.0 REPORT TEST

All EPE components are completely tested and, upon request, you can receive the certificate of inspection by the factory.

1.4.1 TR CERTIFICATE

In most of cases, for importing products into the Russian Federation and former Soviet republics (Belarus, Ukraine, Kazakhstan), you must have various product certificates. The most common one is the TR certificate. This certificate confirms to the end user that the product complies with certain regulations on safety of the Country. Without the certification, the goods cannot be cleared and the end user (importer)

cannot start-up or use the product because it is classified not safe.



1.4a

1.4.2 AUSTRALIAN PRESSURE VESSEL STANDARD

In Australia, it is necessary to define the level of risk that a vessel under pressure represents.

The level of risk is a function of: volume to pressure, type of content (flammable/unstable, its compressibility, operating conditions (static, movable, proximity to public, etc.).

The degree of risk level is expressed in the Australian Standard with some letters according to "AS4343-1999 - Equipment under pressure - Level of risk".

Any pressure vessel that has a level of risk higher than the level "E" should belong to a registered drawing.

The registration of the drawings is issued by a Government agency in every State of Australia called "Work Safe Australia".

The "Work Safe" will issue the registrations only for vessels under pressure showing to be in accordance with Australian standards: AS1210-1997 - pressure vessels - and, normally, this registration is accepted by the other Australian States.

1.4.3 ML (EX SQL) - CHINA

With the entry of China into the WTO (World Trade Organization), the Chinese State Council has officially issued (02/19/2003) the new regulations on safety supervision of special equipment to be entered in the Chinese market.

The organization "General Administration of Quality Supervision Inspection and Quarantine" (AQSIQ) was authorized to take care of the direct control and management of this special equipment used in China.

To this control system must therefore be subject even the special equipment that are imported into China from all over the world.

In place of Safety Quality License Office (SQLO), the offices of SELO (Special Equipment Licensing Office) directly under AQSIQ, become the new operational reference.

SELO is solely responsible for the management of documentation and for the evaluation of the manufacturer in order to obtain of the license (Manufacture License ML).

EPE ITALIANA was authorized by SELO to export its products in China with License ML No. TS2200710-2012.

1.4.4 RINA

RINA certification for the marine industry. RINA is a third party that, in accordance with its rules, tests and certifies various pressure equipment that will be used in the marine industry.

RINA is an associate member of IACS and is authorized to act on behalf of the Italian administration in accordance with EU Directive 94/57 and about 70 other flag administrations.

1.4.7 ASME-U.S.

ASME (American Society of Mechanical Engineers) is an organization that regulates the design and manufacture of pressure vessels. Accumulators are categorized as unfired pressure vessels and fall under the jurisdiction of ASME Code when required by State law.

Accumulators specifically fall under the section of the code referred to Section VIII, Division 1. This section requires certification on vessels with internal diameters of 6" or greater and with the "U" symbol as evidence that they were designed and manufactured in accordance with the Code. The "U" symbol is an internationally recognized symbol of design and quality manufacturing.

The essential criteria of ASME Certification is a requirement of strength and material traceability. Accumulators must be manufactured with materials that meet ASME specifications and require a design factor of 4:1 in the ratio of burst pressure to rated pressure.

This 4:1 requirement is mandatory for all accumulators with ASME Certification with the exception of those that comply with a specific rule within the Code called "Appendix 22".

Appendix 22 permits that accumulators manufactured with "forged" shells, with connections of a specified maximum size, may be certified with a design factor of 3:1 in the ratio of burst pressure to rated pressure.

ASME requires that each vessel is marked with the design pressure at the Minimum Design Metal Temperature (MDMT) for the vessel.

ASME Certification requires third party surveillance of an approved quality system and requires witness by a third party of all hydrostatic testing. Currently, unlike many other standards around the world, there is no ASME national requirement for periodic inspection of accumulators after installation. However, local laws would dictate such inspections.

1.4.8 97/23/EC EUROPE

The Pressure Equipment Directive is one of the series of technical harmonization directives covering subjects such as machinery, simple pressure vessels, gas appliances, etc., which were identified by the European Community's program for the elimination of technical barriers to trade. The purpose of the PED is to harmonize national laws of Member States regarding the design, manufacture, testing and conformity assessment of pressure equipment and assemblies of pressure equipment.

The program aims to ensure the free placing on the market and putting into service of relevant equipment within the European Union and the European Economic Area.

The Directive requires that all pressure equipment and assemblies within its scope must be safe when placed on the market and put into service. The Pressure Equipment Directive applies to the design, manufacture and conformity assessment of pressure equipment and assemblies of pressure equipment with maximum allowable pressure greater than 0.5 bar above atmospheric pressure (i.e.: 1.5 bar of absolute pressure).

The PED Conformity Assessment Forms apply to all accumulators using fluids of Group 2 (i.e.: non-hazardous), with a volume greater than 1 litre and a product of service pressure (PS) and volume (V) greater than 50 bar x litre or for any pressure vessel where PS exceeds 1000 bar.

PED applies in the member States of the European Union (EU) and the European Economic Area (EEA). Similar requirements to PED have been

adopted by many other countries, which joined the European Union.

The EU member States are: Austria, Belgium, Bulgaria, Cyprus, Denmark, Estonia, Finland, France, Germany, Greece, Ireland, Italy, Latvia, Lithuania, Luxembourg, Malta, Netherlands, Poland, Portugal, Czech Republic, Romania, Slovakia, Slovenia, Spain, Sweden, Hungary, and United Kingdom.

The European Economic Area (EEA) includes the 27 EU countries listed above, plus Iceland, Liechtenstein, Norway and Switzerland.

1.4.9 ATEX (94/9/EC)

Fall within the scope of the Directive 94/9/EC also non-electrical equipment that have to be used in potentially explosive atmospheres so they must be certified ATEX according to the customer's risk area. See section 0.8.

As required by the regulation 94/9/EC, in addition to the deposit of the technical dossier, EPE ITALIANA monitors its internal production and constantly checks that the production cycle is consistent with the risk analysis performed on the equipment and it carries out a self-certification.

1.4.10 DNV

«Det Norske Veritas» (DNV) Certification, section «Maritime».

DNV certifies all materials, components and systems that are relevant to the operation of ships in terms of safety and quality. The Classification is a particular type of certification, which is used to confirm that the ships and all structures that exist within it conform to the requirements.

These requirements are specified in the regulations of DNV. The classification, in fact, provides that the same company that performs the classification, namely the institution of the third party, establishes the requirements.

1.4.11 RTN - ROSTECHNADZOR

RTN Rostekhnadzor Certification

The FSETAN RTN ROSTECHNADZOR certificate (former Gosgorteknadzor).

The FSETAN and RTN RosTechNadzor permissions for the use of technological systems (production lines) are required in dangerous industrial areas during flammable and explosive processes and for the use of the related equipment as well as in any other field that may cause danger to the ecology and the human being. The Permissions are granted by the Federal Ecological, Technological and Atomic Monitoring Service according to expert conclusions on the industrial safety carried out by specialists of the Organization. Therefore, all components used on these plants are accompanied by its passport RTN.

1.4.12 ALGERIAN PASSPORT

EPE Italiana is able to supply its components with the Algerian passport for all applications that it's required.

After the approval of the preliminary dossier from the Algerian Ministry of Energy and Certification with endorsement by the Algerian Consulate in Italy and the Italian Chamber of Commerce, will be issued the final dossier in French language and carried out, by third party, the pressure test on the equipment subjected to this certification.

Reproduction is forbidden.

In the spirit of continuous improvement, our products may be changed.

1.5.1 DETAILS OF THE BLADDERS AND/OR SEALS MATERIAL

The bladders can be made of various types of elastomers. To obtain the thermal and chemical compatibility with the fluid used, you must select the proper elastomer, depending on the fluid used and the working temperature. For more precise information than the specifications outlined below, please contact our technical service.

1.5.2 "P" NITRILE RUBBER (NBR)

Nitrile rubber NBR is the generic name of the acryl-nitrile butadiene compound. The content of nitrile-acrylate is greater than 33%, so you have the right balance between a good compatibility with oils and fuels, while maintaining good flexibility at low temperatures. The NBR rubber is highly resistant to ozone and weathering. Heat resistance up to 80°C and for short periods up to 90°C (at higher temperatures, the aging is accelerated). Resistance to low temperatures down to -20°C, for short periods up to -25°C.

Chemical compatibility:

- aliphatic hydrocarbons (propane, butane, gasoline, oils, mineral greases, diesel fuel, fuel oil, kerosene)
- mineral greases and oils
- HFA, HFB, HFC fluids
- many dilute acids, alkalis, salt solutions
- water
- water glycol

Not compatible with:

- fuels with high aromatic content (i.e. premium gasoline)
- aromatic hydrocarbons (benzene)
- chlorinated hydrocarbons (trichloroethylene)
- polar solvents (ketone, acetone, ethylene esters of acetic acid)
- strong acids
- brake fluids based on glycol
- water glycol
- poor resistance to ozone, weathering and aging.

1.5.3 "F" NITRILE RUBBER FOR LOW TEMPERATURES

The same as with standard nitrile and most types of freon. It has lower content of acrylic nitrile with respect to the standard, so it is best suitable to work at low temperatures but the chemical resistance to various liquids is slightly lower. Working temperature -40°C +70°C.

1.5.4 "H" NITRILE RUBBER FOR HYDROCARBONS

Compatible with normal gasoline, super low-aromatic ones, combined heavy oil and all fluids of standard nitrile. Working temperature -10°C +90°C

1.5.5 "K" HYDROGENATED NITRILE (HNBR)

The hydrogenated nitrile rubber is obtained by adding hydrogen to the compound of the NBR rubber, which imparts superior mechanical properties, outstanding abrasion resistance, high tensile strength, excellent resistance to high temperatures, low gas permeability. Heat resistance up to 130°C, with higher peaks for short periods of up to 150°C. Resistance to low temperatures up to -30°C.

Chemical compatibility greater than the NBR rubber.

1.5.6 "B" BUTYL (IIR)

The butyl rubber has low gas permeability and good electric insulation capacity. Heat resistance up to 100°C, with higher peaks for short periods of up to 120°C. Resistance to low temperatures up to -30°C.

Chemical Compatibility:

- hot water up to 100°C
- brake fluids based on glycol
- many acids and bases
- salt solutions
- polar solvents such as alcohols, ketones and esters
- polyglycol-based hydraulic fluids (HFC fluids) and bases of phosphoric acid esters (HFD-R fluids)
- silicone oils and greases
- Skydrol 500 e 7000
- resistance to ozone, weathering and aging

Not compatible with:

- mineral oils and greases
- fuels
- chlorinated hydrocarbons

1.5.7 "E" ETHYLENE-PROPYLENE (EPDM)

EPDM is a rubber derived from the copolymerization of ethylene with propylene and diene, so it has features particularly suitable to contact with hydraulic fluids based on phosphate esters; it can be also used with fluids of the glycol-based brake systems. Heat resistance up to 100°, with higher peaks for short periods of up to 120°C. Resistance to low temperatures up to -30°C.

Chemical Compatibility:

- hot water up to 100°C
- brake fluids based on glycol
- many organic and inorganic acids
- detergents, sodium and potassium solutions
- hydraulic fluids based on phosphate esters (HFD-R)
- silicone oils and greases
- many polar solvents (alcohol, ketones, esters)
- Skydrol 500 and 7000
- resistance to ozone, weathering and aging

Not compatible with:

- mineral oils and greases
- fuels

1.5.8 "N" CHLOROPRENE (CR)

Trade name NEOPRENE.

Chloroprene rubber is one of the first rubbers created synthetically. Given the high content of chlorine, vulcanizing items have good flammability. They burn under direct action of the flame, but go out when it goes away. The compatibility to the oil is medium, good mechanical properties in the wide temperature range of use. Heat resistance up to 100°C, with higher peaks for short periods of up to 110°C. Resistance to low temperatures up to -30°C.

Chemical Compatibility:

- mineral paraffin oils

- silicone oils and greases
- water and aqueous solutions
- refrigerants (ammonia, carbon dioxide, Freon)
- naphthenic mineral oils
- low molecular aliphatic hydrocarbons (propane, butane, gasoline)
- brake fluids based on glycol
- better resistance to ozone, weathering and aging than in NBR rubber.

Not compatible with:

- aromatic hydrocarbons (benzene)
- chlorinated hydrocarbons (trichloroethylene)
- polar solvents (ketones, esters, ethers, acetone).

1.5.9 "Y" EPICHLOROHYDIN (ECO)

The epichlorohydrin rubber is a copolymer which has good compatibility with mineral oils, fuels and ozone. The high temperature resistance is good; it still has a good elasticity at low temperature, while the gas permeability is not excellent. Heat resistance up to 110°C, with higher peaks for short periods of up to 120°C. Resistance to low temperatures up to -30°C.

Chemical Compatibility:

- mineral oils and greases
- aliphatic hydrocarbons (propane, butane and gasoline)
- silicone oils and greases
- water at ambient temperature
- resistance to ozone, weathering and aging

Not compatible with:

- aromatic hydrocarbons and chlorinated solutions
- ketones and esters
- non-flammable hydraulic fluids of HFD-R and HFD-S groups
- brake fluids based on glycol

1.5.10 "V" FLUOROCARBON (FPM)

The trade name ("DuPont") is VITON®. The fluorocarbon rubber has excellent resistance to high temperatures, ozone, oxygen, mineral oils, synthetic hydraulic fluids, fuels and many chemicals and organic solutions. In the field of low temperatures, its behaviour is not optimal. The permeability to gases is very low, similar to that of butyl. Heat resistance up to 180°C, for short periods of up to 200°C. Resistance to low temperatures up to -10°C.

Chemical Compatibility:

- mineral oils and greases
- non-flammable fluids of HFD group
- silicone oils and greases
- animal and vegetable oils and greases
- aliphatic hydrocarbons (gasoline, butane, propane, natural gas)
- aromatic hydrocarbons (benzene, toluene)
- chlorinated hydrocarbons (tetrachloroethylene, carbon tetrachloride)
- fuels (normal, premium and containing methanol)
- good resistance to ozone, weathering and aging.

Not compatible:

- polar solvents (acetone, methyl ethyl ketone, ethyl acetate, diethyl ether, dioxane)
- Skydrol 500 and 7000

- brake fluids based on glycol
- ammonia gas, amines, alkali
- superheated steam
- low molecular organic acids (formic and acetic acid).

1.5.11 POLYURETHANE (HPU)

The H-PU polyurethane is a copolymer, based on aromatic isocyanate and diols.

Compared to all other elastomers, it has excellent wear resistance, excellent resistance to extrusion and high elasticity. The gas permeability is good compared to that of IIR. Heat resistance: up to approx. +80°C; resistance to low temperatures: up to approx. -20°C.

Chemical Compatibility:

- pure hydrocarbons
- natural oils and greases
- silicone oils and greases
- water up to +50°C
- resistance to ozone and aging

Not compatible with:

- ketones, esters, ethers, alcohols, glycols
- hot water, steam, alkalis, amines, acids

Resistant to:

- oil, petrol, hot water, hot air, ozone, synthetic and native esters

Not resistant to:

- conc. Acids, conc. lyes, conc. alcohols and aromatic solvents.

1.5.12 SILICON-FLUORINE (MFQ)

The rubber MFQ contains in its molecule, as well as methyl groups, even trifluoropropyl groups. The physical and mechanical properties are comparable to those of silicone rubber (MVQ). In comparison to silicone (MVQ), the silicon fluoride (MQF) shows a significantly higher compatibility to fuels and mineral oils, while resistance to the hot air is slightly lower.

Heat resistance: up to approx. 150°C. (max. 180°C)

Resistance to low temperatures: up to approx. +50°C

Chemical Compatibility:

- mineral aromatic oils (i.e. ASTM Oil No. 3)
- fuels
- aromatic low molecular hydrocarbons (i.e. benzene, toluene)
- engine oils and aliphatic type transmissions
- animal and vegetable oils and greases
- brake fluids based on glycol
- non-flammable hydraulic fluids, HFD-R and HFD-S fluids
- chlorinated aromatic hydrocarbons with high molecular content (i.e. Chlophen), chlorinated diphenyl
- water up to +70°C
- dilute salt solutions
- resistance to ozone, aging and weathering

Not compatible with:

- superheated steam over 100°C
- acids and alkalis

- silicone oils and greases
- low molecular chlorinated hydrocarbons (i.e. trichloroethylene)

1.5.12 TEFLON (PTFE)

Normally it is better known by its trade name Teflon®, in which other stabilizers and plasticizers are added to the polymer to improve the characteristics depending on the application. It's a plastic smoother to the touch and resistant to high temperatures (up to 200°C).

The main features are:

- the complete chemical inertia, so it's not attacked by almost all chemical compounds (with the exception of molten alkali metals, fluorine at high pressure and some fluorine compounds under particular conditions of temperature) and especially it does not change the fluids with which is placed in contact, such as high purity fluids for the electronics industry
- the complete insolubility in water and in any organic solvent
- good electric quality (65 kV / mm of dielectric strength)
- excellent resistance to fire: it does not propagate the flame
- Excellent flow properties on the surface: the coefficient of friction is the lowest among the industrial sealing products
- Non-stick: the surface cannot be glued (contact angle is of 127°)

These characteristics take on added importance when you take into account that remain virtually unchanged in a range of temperatures from - 50°C and 150°C (max. 200°C).

Chemical Compatibility:

- Teflon has a high chemical compatibility with most fluids and chemicals used.

Not compatible with:

- hardly compatible with fuel oils in general

1.5.13 THE GAS PERMEABILITY ISSUE SIMPLIFIED

As you gain low temperature capability in a bladder compound, permeability of the bladder increases, and hence greater pre-charge loss due to gas permeation at working temperature.

To show the direct correlation, the potential permeability of each bladder compound was tested to define the relationship between the bladder compound permeability and temperature.

The Gas Permeability Factor was determined by rating the permeability (potential loss of gas pre-charge through the bladder or through the seal) of each compound on a scale of 0 to 50 at 70°F. The higher the Permeability Factor of the faster gas pre-charge would be lost in a low-temperature application using that bladder compound.

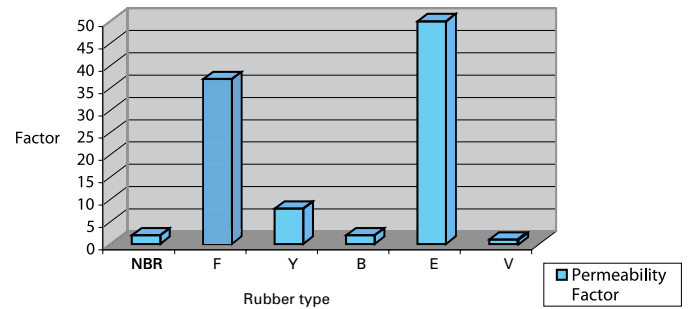
Specifically:

Rubber type	TSmin °C	Permeability Factor
"P" Nitrile (NBR)	- 20	3
"F" Nitrile (NBR-LT)	- 40	30
"Y" Epichlorohydrin ECO)	- 30	8
"B" Butyl (IIR)	- 30	2
"E" Ethylene-propylene(EPDM)	- 30	50
"V" Fluorocarbon (FPM)	- 10	1

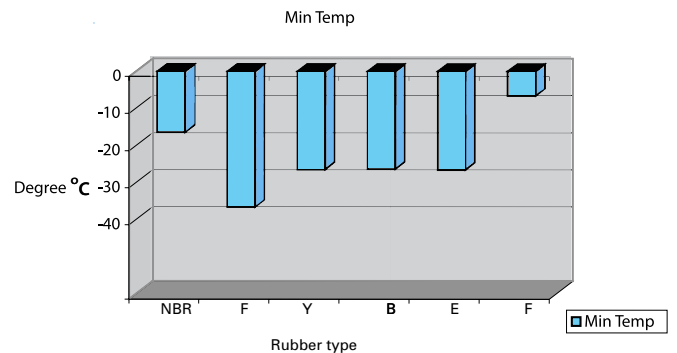
The Permeability Factor increases or decreases with temperature, setting up a trade-off situation for having to use a low temperature bladder compound. If the application requires a - 40°C bladder material because the equipment needs to be left out the cold overnight, the upside is that the bladder won't shatter at low temperature.

The downside is that the pre-charge in the bladder will have to be checked more often because of the higher working temperature when the oil warms up.

The following charts will assist bladder accumulator users when they have a low temperature application. Figure 1.5a Permeability Factor & Bladder Compounds shows the permeability of each compound within a 0 to 50 Permeability Factor scale.



1.5a



1.5b

Figure 1.5b- Minimum Use Temperature & Bladder Compounds shows the lowest temperature at which each bladder compound can be used. With reference to both charts, it is graphically easy to see that the nitrile low temperature compound, for example, has excellent low temperature capability at - 40°C, but the trade-off for that low temperature performance is a relatively high Permeability Factor of 30. This is a solid confirmation that using this bladder compound will require more frequent maintenance checks for the loss of pre-charge due to gas permeation.

Reproduction is forbidden.

In the spirit of continuous improvement, our products may be changed.



DEFINITIONS AND UNITS OF MEASUREMENT

2.1



CALCULATION OF THE ACCUMULATOR

2.2

2.1.1 DEFINITIONS

Po = nitrogen pre-charge pressure (relative to the atmospheric pressure, namely the "relative pressure"). Measure to be performed when the accumulator is completely oil-free and at a temperature of $20 \pm 2^\circ\text{C}$.

P1 = minimum working pressure of the hydraulic circuit (relative to the atmospheric pressure, namely the "relative pressure"). The minimum pressure must be higher than the pre-charge pressure.

P2 = maximum working pressure of the hydraulic circuit (relative to the atmospheric pressure, namely the "relative pressure").

P3 = calibration pressure of the safety valve (relative to the atmospheric pressure, namely the "relative pressure"). The pressure calibration of the safety valve must be greater than P2 at least of the hysteresis of the safety valve but equal or lower than the PS value.

PS = maximum working pressure of the accumulator (relative to the atmospheric pressure, namely the "relative pressure").

PT = testing pressure of the accumulator (relative to the atmospheric pressure, namely the "relative pressure"). Usually $PT = PS \times 1.43$.

ΔP = is the difference between the maximum and minimum working pressure ($P2 - P1$).

Po/P2 = compression ratio.

Vo = volume of gas under Po pressure

V = volume of fluid when the accumulator is completely full.

VoA = gas volume of the accumulator in case of a transfer bladder or piston accumulator.

V1 = volume of gas under P1 pressure.

V2 = volume of gas under P2 pressure.

V3 = volume of gas under P3 pressure.

ΔV = useful volume. It indicates the difference in volume of the working fluid between V1 and V2. Volume made by the accumulator during the working phase.

TSmin = minimum working temperature.

TSmax = maximum working temperature.

T20 = reference temperature at 20°C .

ts = discharge time of ΔV of the fluid.

tr = recharge time of ΔV of the fluid.

tc = plant cycle time. On a cyclical machine, it's the time between the start of a discharge of ΔV and the start of the next discharge.

N = number of cycles in a time unit.

η = polytropic exponent.

Q = flow rate by volume.

2.1.2 UNIT OF MEASUREMENT

Pressure - Force/Surface

Pascal	Pa	1 Pa = 1 N/m ² 1 kPa = 0.01 bar = 0.1 N/cm ² = 0.10 mH ₂ O = 7.5 mmHg = 0.0099 atm = 0.145 psi = 0.02088 lbf/ft ² = 0.334 ftH ₂ O
bar	bar	1 bar = 100'000 Pa = 100 kPa = 0.1MPa = 1.0197 kg/cm ² = 10.198 mH ₂ O = 750 mmHg = 0.987 atm = 14.5 psi = 33.455 ftH ₂ O
millibar	mbar	1 mbar = 100 Pa = 0.010 mH ₂ O = 0.750 mmHg = 0.00102 kg/cm ² = 0.0145 psi = 2.088 lbf/ft ² = 0.033 ftH ₂ O
millimetres of mercury	mmHg	1 mmHg = 133.322 Pa = 0.133 kPa = 0.00133 bar = 0.0136 mH ₂ O = 0.00131 atm = 0.00136 kg/cm ² = 0.01934 psi = 2.78 lbf/ft ² = 0.045 ftH ₂ O
technical atmosphere = kgf/cm²	at Kg/cm²	1 at = 1 kg/cm ² = 735.56 mmHg = 10 mH ₂ O = 98066.50 Pa = 98.067 kPa = 0.981 bar = 0.968 atm = 14.22 psi = 2048.16 lbf/ft ² = 32.81 ftH ₂ O
metric atmosphere	atm	1 atm = 101'325 Pa = 760 mmHg = 1.033 at = 10.33 mH ₂ O = 1.01 bar = 14.696 psi = 2116.22 lbf/ft ² = 33.9 ftH ₂ O
water column metres	m_{H2O}	1 mH ₂ O = 9806 Pa = 0.09806 bar = 73.55 mmHg = 0.9806 N/cm ² = 0.09678 atm = 0.0999 at = 1.4224 psi = 204.8 lbf/ft ² = 3.28 ftH ₂ O
foot of water	ft_{H2O}	1 ftH ₂ O = 2988.87 Pa = 0.0299 kPa = 0.3048 mH ₂ O = 22.419 mmHg = 0.0295 atm = 0.03048 kg/cm ² = 0.4335 psi = 62.42 lbf/ft ²

pounds per square inch	psi	1 psi = 6.894.76 Pa = 6.894 kPa = 0.069 bar = 0.703 mH ₂ O = 51.715 mmHg = 0.689 N/cm ² = 0.068 atm = 0.0703 kg/cm ² = 144 lbf/ft ² = 2.31 ftH ₂ O
pounds per square foot	lbf/ft²	1 lbf/ft ² = 2'988.87 Pa = 2.99 kPa = 0.0299 bar = 0.3048 mH ₂ O = 22.418 mmHg = 0.299 N/cm ² = 0.0295 atm = 0.0305 at = 0.433 psi = 62.424 lbf/ft ²

Volume

cubic meter	m³	1 m ³ = 1'000 dm ³ = 35.3146 ft ³ = 61'023.744 in ³ = 1.308 yd ³ = 264.20 galUS = 219.97 galUK
cubic decimetre; litre	dm³	1 dm ³ = 1 l = 0.001 m ³ = 61.024 in ³ = 0.0353 ft ³ = 0.00131 yd ³ = 0.26417 galUS = 0.21997 galUK
cubic centimetre	cm³, cc	1 cm ³ = 0.001 dm ³ = 0.001 l = 0.061 in ³ = 0.000264 galUS = 0.00022 gal UK
cubic inch	in³	1 in ³ = 0.0000164 m ³ = 0.0164 dm ³ = 0.0005787 ft ³ = 0.0043 galUS = 0.0036 galUK
cubic foot	ft³	1 ft ³ = 0.02832 m ³ = 28.32 dm ³ = 1'728 in ³ = 0.037 yd ³ = 7.48 galUS = 6.23 galUK
cubic yard	yd³	1 yd ³ = 0.764 m ³ = 764.55 dm ³ = 46.656 in ³ = 27 ft ³ = 201.97 galUS = 168.18 galUK
gallon US	galUS	1 galUS = 0.00378 m ³ = 3.785 dm ³ = 231 in ³ = 0.134 ft ³ = 0.0049 yd ³ = 0.833 galUK
gallon UK	galUK	1 galUK = 0.00455 m ³ = 4.546 dm ³ = 277.42 in ³ = 0.16 ft ³ = 0.0059 yd ³ = 1.2 galUS

Temperature

kelvin	K	K = °C + 273.15 K = 1.8 · °R K = [5/9 · °F] + (459.67/1.8)
degree Centigrade	°C	°C = (°F - 32) · 5/9 °C = K - 273.15 °C = (5/9) · °F - (32/1.8)
degree Fahrenheit	°F	°F = 9/5 · °C + 32 °F = °R - 459.67 °F = (9/5) · K - 459.67
degree Rankine	°R	°R = (5/9) K °R = 491.67 + (9/5) · °C °R = 459.67 + °F

Time

seconds	s	s = 0.01666667 min s = 0.00027778 h s = 0.00001157 days
minutes	min.	min = 60 s min = 0.01666667 h min = 0.00071428 days
hours	h	h = 60 min h = 0.04166667 days h = 3600 s
days	days	day = 86400 s day = 1440 min day = 24 h

Flow rate by volume

cubic meters per second	m³/s	1 m ³ /s = 60 m ³ /min = 3'600 m ³ /hour = 1'000 l/s = 60'000 l/min = 6'102'374.42 in ³ /s = 2'118.88 ft ³ /min = 15'850.32 gpm = 13'198.13 l gpm
cubic meters per minute	m³/min	1 m ³ /min = 0.0167 m ³ /s = 60 m ³ /h = 16.67 l/s = 1'000 l/min = 35.31 ft ³ /min = 264.17 gpm = 219.97 l gpm
cubic meters per hour	m³/h	1 m ³ /h = 0.000278 m ³ /s = 0.0167 m ³ /min = 0.28 l/s = 16.67 l/min = 1017.06 in ³ /s = 0.588 ft ³ /min = 4.40 gpm = 3.66 l gpm
litres per second	l/s	1 l/s = 0.001 m ³ /s = 0.06 m ³ /min = 3.6 m ³ /h = 60 l/min = 3661.42 in ³ /min = 2.12 ft ³ /min = 15.85 gpm = 13.198 l gpm
litres per minute	l/min	1 l/min = 0.001 m ³ /min = 0.06 m ³ /h = 0.0167 l/s = 61.024 in ³ /min = 0.035 ft ³ /min = 0.264 gpm = 0.22 l gpm
cubic inch per minute	in³/min	1 in ³ /min = 0.00027 l/s = 0.016 l/min = 0.00058 ft ³ /min = 0.0043 gpm = 0.0036 l gpm
cubic foot per minute	ft³/min	1 ft ³ /min = 0.00047 m ³ /s = 0.028 m ³ /min = 1.7 m ³ /h = 0.472 l/s = 28.32 l/min = 1'728 in ³ /min = 7.48 gpm = 6.23 l gpm
gallon per minute	gpm	1 gpm = 0.0038 m ³ /min = 0.227 m ³ /h = 0.063 l/s = 3.785 l/min = 231 in ³ /min = 0.134 ft ³ /min = 0.833 l gpm
imperial gallon per minute	l gpm	1 l gpm = 0.000076 m ³ /s = 0.00454 m ³ /min = 0.273 m ³ /h = 0.076 l/s = 4.55 l/min = 277.42 in ³ /min = 0.16 ft ³ /min = 1.2 gpm

2.2.1 PRINCIPLE OF OPERATION

Gas compression

In hydropneumatic accumulators, oil or other liquids are maintained under pressure by a pre-compressed gas, usually nitrogen. Therefore, we show some principles on the compression of gases, useful then in the calculation of the accumulators. The fundamental characteristics of a gas are: volume, temperature and pressure.

The law governing these functions is the one on the ideal gases of Boyle and Mariotte, which states that in every condition under which we place a certain amount of gas, the product between its pressure (relative to vacuum) and its volume is constant. The law adds that this remains constant even if the passage from one state to another occurs with equal heat exchange with the external environment.

This means that, for a given quantity of gas, if the volume available is halved, the pressure is twice; the product of the volume for the absolute pressure is constant.

$$P_1 \cdot V_1 = P_2 \cdot V_2 = P_3 \cdot V_3 = \dots = \text{constant}$$

According to the law of Gay-Lussac: at constant volume, in an ideal gas, the absolute pressure and the temperature are directly proportional. Maintaining a constant pressure in an ideal gas, its volume V varies directly with temperature T :

$$V_1 : V_2 = T_1 : T_2$$

And maintaining a constant volume, the pressure varies in proportion to temperature changes:

$$P_1 : P_2 = T_1 : T_2$$

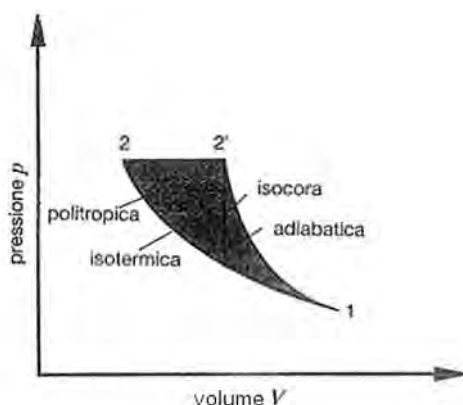
From this it follows that an increase in pressure leads to an increase in temperature and, conversely, a decrease in pressure causes a decrease in temperature. The laws of Boyle and Mariotte and Gay-Lussac are valid exactly only for ideal gases; the nitrogen, being a real gas, is bound to small and influential changes than the laws of the compression of ideal gases. Another crucial factor concerns the change of the aeriform state.

Change in gas state

The state change of the gas may be:

- isochore
- isothermal
- adiabatic
- polytropic

Diagram 2.2a : change of state in the diagram P - V



2.2a

Changes in isochore

This change of state is characterized by a constant volume of gas. It occurs when the gas area of the accumulator is pre-charged at low temperature and then subjected to a pressure increase at constant volume due to heat exchange with the environment.

$$\text{Equation of state: } P/T = P_1/T_1 = \text{constant}$$

Isothermal change

This variation, characterized by the constant temperature of the gas, occurs when the charging or discharging of the fluid to / from the accumulator occurs in long times, allowing for the complete heat exchange between the gas and the environment (more than 180 seconds).

$$\text{Equation of state: } P \times V = P_1 \times V_1 = \text{constant}$$

Adiabatic change

The adiabatic change occurs when the discharge and charge of the fluid to / from the accumulator is so fast as to prevent any heat exchange between the gas and the environment (less than 60 seconds).

$$\text{Equation of state: } P \times V^k = P_1 \times V_1^k = \text{constant}$$

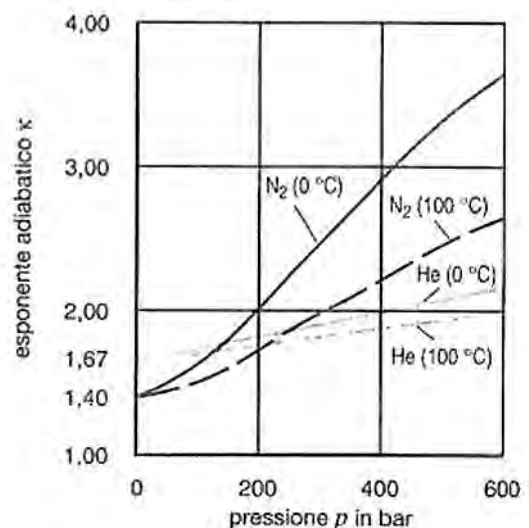
The relationships between temperature and volume and between temperature and pressure are expressed by the thermal equations of state:

$$T \times V^{k-1} = T_1 \times V_1^{k-1}$$

$$T \times P^{(1-k)/k} = T_1 \times P_1^{(1-k)/k}$$

In these equations, "k" is the adiabatic exponent, which for a diatomic gas such as nitrogen under normal conditions, is equal to 1,4.

Diagram 3: evolution of the adiabatic nitrogen exponent depending on the pressure at temperatures of 0°C and 100°C.



2.2b

Polytropic change

The operation of an accumulator never occur under the theoretical assumptions, namely without heat exchange. In practice, there is an intermediate change of state between the isothermal and adiabatic ones, which takes the name of polytropic.

The valid relations are similar to those of the adiabatic change, but it has to substitute the adiabatic change adiabatic exponent with the polytropic exponent N .

2.2.2 SIZING OF THE ACCUMULATOR

With the sizing of the accumulator, we want to establish the geometric capacity according to the pressures within which it works, the amount of fluid that it has to store and return and the time required.

In light of the above, it follows that the equations to be used for the calculation of an accumulator depends on the actual duration of the process of absorption/delivery of the fluid.

As empiric rule for choosing the appropriate equations, apply the following criteria:

- cycle duration < 1 minute: adiabatic change
- cycle duration < 3 minutes: isothermal change
- cycle duration between 1 and 3 minutes: polytrophic change.

The equations to be used for the calculation of the accumulator are shown in Table 3. It should also be noted that the calculation of the accumulator involves some experimental values, which, on one hand, ensure the optimal exploitation of the accumulator volume and, on the other, allow not to endanger the duration. Table 2 shows the experimental values for the various types of accumulators.

Deviations of the real gases

The equations of state shown in the preceding paragraphs apply only if the gas follows the ideal behaviour. In fact, various gases such as nitrogen, differ (especially at other pressures) by the laws of the ideal gas. This behaviour is called "real".

For real gases, relations between the parameters of state (P, T, and V) can be represented only by approximate equations, whose sufficiently precise use is very laborious and long. We prefer, therefore, to take into account the behaviour of the real gases by introducing appropriate correction factors.

In this case, the real volume for an isothermal change of state is expressed by

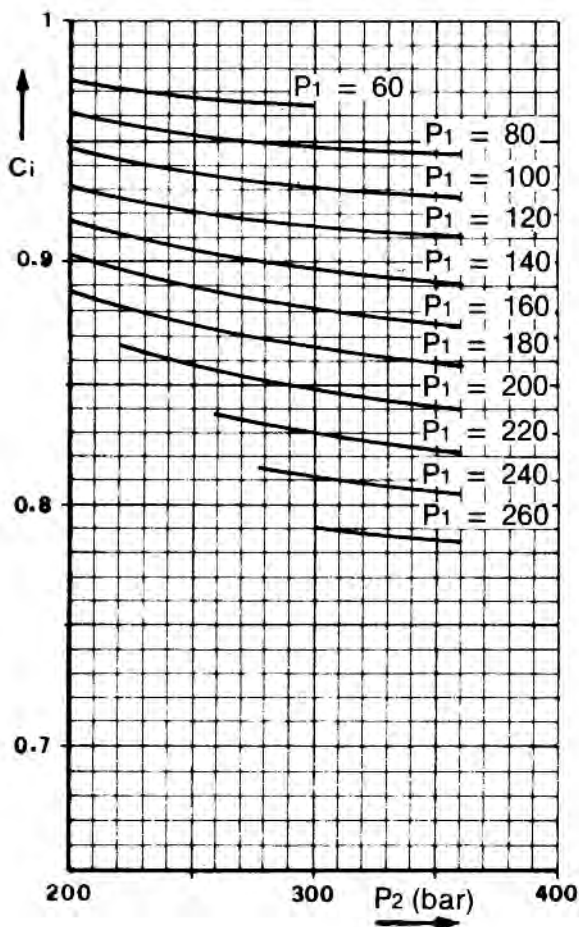
$$V_{0 \text{ real}} = C_i \times V_{0 \text{ ideal}}$$

and for an adiabatic change of state is expressed by

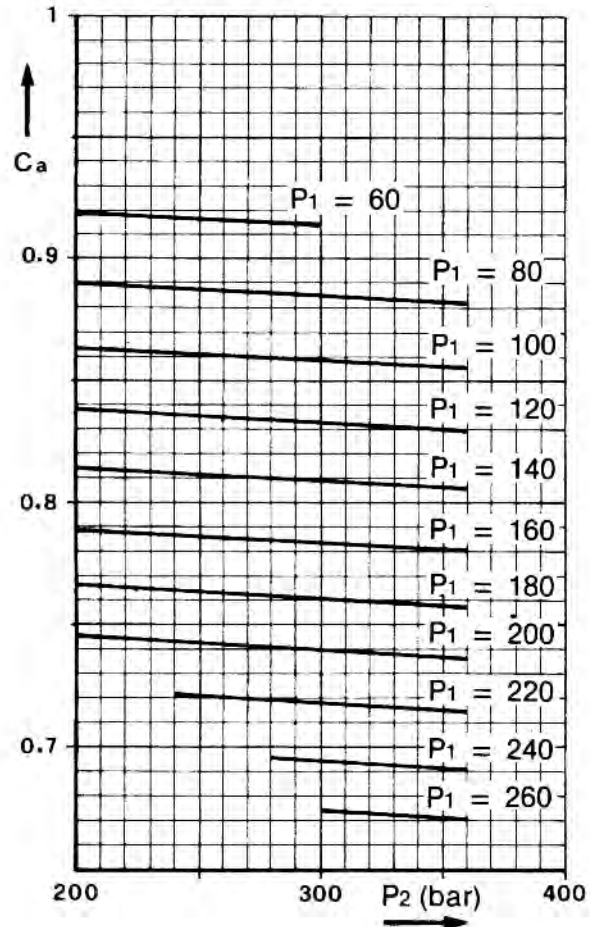
$$V_{0 \text{ real}} = C_a \times V_{0 \text{ ideal}}$$

The correction factors C_i and C_a in the equations can be obtained from the following diagrams

Isothermal correction coefficient C_i



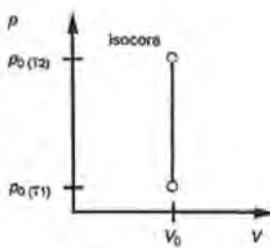
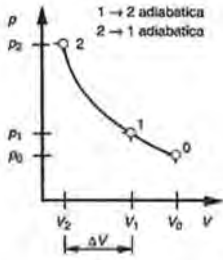
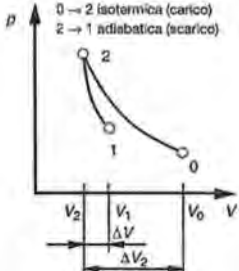
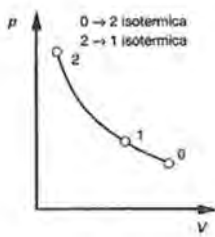
Adiabatic correction coefficient C_a



2.2c

Accumulator	Bladder accumulator High pressure	Bladder accumulator Low pressure	Diaphragm accumulator welded -	Diaphragm accumulator screwed	Piston accumulator with reduced friction
Gas pre-charge pressure P_0 (T_b) (at max. working temperature)	$\leq 0.9 \cdot p_1$ (accumulation of energy) = (0.6-0.9) $\cdot p_m$ (shock absorption)		$\leq 0.9 \cdot p_1$ (accumulation of energy) $0.6 \cdot p_m$ (pulsations damping)		$\leq p_1 - 5$ bar < 2 bar (piston with reduced friction) < 10 bar (normal piston)

2.2d

Cycle (state change)	Equation	Notes
	$P_{0(T1)} = P_{0(T2)} \cdot T_{s \text{ min}} / T_{s \text{ max}}$	$P_{0(T1)}$ = pre-charge pressure at minimum temperature $T_{s \text{ min}}$ (degrees Kelvin) $P_{0(T2)}$ = pre-charge pressure at maximum temperature $T_{s \text{ max}}$ (degrees Kelvin) Use Calculation of the pre-charge pressure when the operating temperature is different from the pre-charge temperature.
	$\Delta V = V_0 [(p_0/p_1)^{1/n} - (p_0/p_2)^{1/n}]$ $V_0 = \Delta V / [(p_0/p_1)^{1/n} - (p_0/p_2)^{1/n}]$	$\eta = K = 1.4$ for nitrogen (p_0 at temperature $T_{s \text{ min}}$) Use Accumulation of energy
	$\Delta V_2 = V_0 p_0/p_2 [(p_0/p_1)^n - 1]$ $V_0 = \Delta V \cdot p_2 / p_0 / [(p_2/p_1)^{1/n} - 1]$	Use Emergency, safety (p_0 at temperature $T_{s \text{ min}}$)
	$\Delta V = V_0 (p_0/p_1 - p_0/p_2)$ $V_0 = \Delta V / [p_0/p_1 - p_0/p_2]$	Use Leak and volume compensation (p_0 at temperature $T_{s \text{ min}}$)

2.2e



Temperature variation

Temperature variation can seriously affect the pre-charge pressure of an accumulator. As the temperature increases, the pre-charge pressure increases; conversely, decreasing temperature will decrease the pre-charge pressure. In order to assure the accuracy of your accumulator pre-charge pressure, you need to factor in the temperature variation.

The temperature change is determined by the temperature encountered during the pre-charge versus the operating temperature expected in the system.

NOTE: it is important to wait for the thermal exchange caused by pressure shifts to be stabilized in order to check or adjust the pre-filling pressure. As a safety measure, isolate the nitrogen source during the stabilization period.

Equation used

This equation is used for correction of nitrogen filling pressure P_0 in relation to the operating temperature.

$$P_0(T_s) = P_0(T_{20}) \times \frac{T_s + 273}{T_{20} + 273}$$

$P_0(T_s)$ = filling pressure at checking temperature

$P_0(T_{20})$ = nitrogen pressure P_0 at 20°C

NITROGEN FILLING PRESSURE	200	173	183	186	193	200	207	214	221	227	234	241	248	255	261	268
	190	164	171	177	184	190	197	203	210	216	222	229	235	246	248	255
	180	155	162	168	174	180	186	192	198	205	211	217	223	229	235	241
	170	147	153	158	164	170	176	182	187	193	199	205	211	216	222	228
	160	138	144	149	155	160	166	171	176	182	187	193	198	204	209	215
	150	130	135	140	145	150	155	160	165	171	176	181	186	191	196	201
	140	121	126	130	135	140	145	150	154	159	164	169	173	178	183	188
	130	112	117	121	126	130	134	139	143	148	152	157	161	166	170	174
	120	104	108	112	116	120	124	128	132	136	141	145	149	153	157	161
	110	95	99	103	106	110	114	118	121	125	129	133	136	140	144	148
	105	91	94	98	101	105	109	112	116	119	123	127	130	134	137	141
	100	86	90	93	97	100	103	107	110	114	117	120	124	127	131	134
	95	82	85	89	92	95	98	102	105	108	111	115	118	121	124	127
	90	78	81	84	87	90	93	96	99	102	105	108	112	115	118	121
	85	73	76	79	82	85	88	91	94	97	100	102	105	108	111	114
	80	69	72	75	77	80	83	86	88	91	94	96	99	102	105	107
	75	65	67	70	72	75	78	80	83	85	88	90	93	96	98	101
	70	60	63	65	68	70	72	75	77	80	82	84	87	89	92	94
	65	56	58	61	63	65	67	69	72	74	76	78	81	83	85	87
	60	52	54	56	58	60	62	64	66	68	70	72	74	76	78	81
55	48	49	51	53	55	57	59	61	63	64	66	68	70	72	74	
50	43	45	47	48	50	52	53	55	57	59	60	62	64	65	67	
45	39	40	42	43	45	47	48	50	51	53	54	56	57	59	60	
40	35	36	37	39	40	41	43	44	45	47	48	50	51	52	54	
35	30	31	33	34	35	36	37	39	40	41	42	43	45	46	47	
30	26	27	28	29	30	31	32	33	34	35	36	37	38	39	40	
25	22	22	23	24	25	26	27	28	28	29	30	31	32	33	34	
20	17	18	19	19	20	21	21	22	23	23	24	25	26	26	27	
15	13	14	14	15	15	16	16	17	17	18	18	19	19	20	20	
10	8.6	9	9.3	9.7	10	10.4	10.8	11.1	11.4	11.8	12.2	12.6	13	13.4	13.8	
5	4.3	4.5	4.7	4.8	5	5.2	5.3	5.5	5.7	5.9	6	6.2	6.4	6.5	6.7	
	-20	-10	0	10	20	30	40	50	60	70	80	90	100	110	120	
REFERENCE TEMPERATURE °C																

2.2f

2.2.3 EMERGENCY ENERGY RESERVE WITH BLADDER ACCUMULATOR

Typical occasion when storage is slow (isothermal) and discharge is quick (adiabatic).

Volume will be given by:
 $V_0 = \Delta V / (P_0/P_2)^{1/n} \cdot [(P_2/P_1)^{1/n} - 1]$

And stored volume by:
 $\Delta V = V_0 (P_0/P_2)^{1/n} \cdot [(P_2/P_1)^{1/n} - 1]$

Where:
n = 1.4 adiabatic coefficient (quick discharge phase)
n_c = 1 ÷ 1.4 polytropic coefficient (slow storage phase)

$$V_0 = \Delta V P_2/P_0 / (P_2/P_1)^{0.7143} - 1 ; \quad \Delta V = V_0 P_0 (P_2/P_0)^{0.7143} - 1 / P_2$$

Example:

An accumulator must discharge 4.6 litres of oil in 3 seconds with a change of pressure from $P_2 = 280$ bar to $P_1 = 220$ bar. The loading time is 4 minutes. Define the capacity keeping in mind that ambient temperature will change from 20°C to 50°C.

$$V_0 = \Delta V / (P_0/P_2)^{1/1.1} - [(P_2/P_1)^{1/1.4} - 1]$$

$$= 4.6 / (199/281)^{0.09091} \cdot [(281/221)^{0.7143} - 1] = 33.63 \text{ l}$$

$$P_1 = 221 \text{ abs. bar} \quad n_c = 1.1 \text{ (from Fig.2.2a)}$$

$$P_2 = 281 \text{ abs. bar} \quad T_1 = (273+20) = 293 \text{ °K}$$

$$P_0 = 0.9 \times 220 = 198 = 199 \text{ bar abs.} \quad T_2 = (273+50) = 323 \text{ °K}$$

Considering the correction coefficient for high pressure and the temperature change, we have:

$$V_{ot} = V_0 / C_m \times T_2 / T_1 = 33.63 / 0.777 \times 323 / 293 = 47.7 \text{ l}$$

Where:
 $C_a = 0.72$
 $C_i = 0.834$
 $C_m = C_a + C_i / 2 = 0.777$

The pre-charge pressure at 20°C will be:

$$P_{0(20^\circ\text{C})} = 199 \times 293 / 323 = 180.5 \text{ bar} = 179.5 \text{ rel. bar}$$

The accumulator type is **AS55P360**.....

2.2.4 PULSATION COMPENSATOR Q WITH BLADDER ACCUMULATOR

A typical calculation in adiabatic conditions due to high speed storage and discharge.

The fluid amount ΔV to be considered in the calculation depends on the type and capacity of the pump:

$$\Delta V = K \cdot q$$

Volume becomes:
 $V_0 = K \cdot q / (P_0/P_1)^{0.7143} - (P_0/P_2)^{0.7143}$

Where:

q = pump displacement (litres)
 = $A \times C$ (piston surface x stroke)
 = Q/n = flow rate (l/min) / strokes/min.

P = average working pressure (bar)

$P_1 = P - X$ (bar)

$P_2 = P + X$ (bar)

$X = \alpha \cdot P / 100$ (bar) deviation from average pressure

α = remaining pulsation \pm (%)

K = coefficient taking into account the number of pistons and if pump is single or double acting.

Pump type	K
1 piston, single acting	0.69
1 piston, double acting	0.29
2 pistons, single acting	0.29
2 pistons, double acting	0.17
3 pistons, single acting	0.12
3 pistons, double acting	0.07
4 pistons, single acting	0.13
4 pistons, double acting	0.07
5 pistons, single acting	0.07
5 pistons, double acting	0.023
6 pistons, double acting	0.07
7 pistons, double acting	0.023

2.2g

Example:

Assume a 3-piston pump, single acting, with a flow rate $Q = 8$ m³/h and operating pressure of 20 bar. Calculate the volume necessary to limit the remaining pulsation to $\alpha = \pm 2.5\%$. Pump RPM 148. Working pressure 40°C.

$$P = 20 \text{ bar} \quad q = 8000 / 60 \times 148 \times 3 = 0.3 \text{ l}$$

$$P_2 = (20 - 0.5) = 19.5 \text{ bar} \quad K = 0.12$$

$$P_1 = (20 + 0.5) = 20.5 \text{ bar} \quad X = 2.5 \times 20 / 100 = 0.5 \text{ bar}$$

$$P_0 = (0.7 \cdot 20) = 14 \text{ bar}$$

$$V_0 = 0.12 \times 0.3 / (15/20.5)^{0.7143} - (15/21.5)^{0.7143} = 1.345 \text{ l}$$

$$P_{0(20^\circ\text{C})} = 15 \times 293 / 313 = 14 \text{ abs. Bar} = 13 \text{ bar rel.}$$

The most suitable accumulators is the low pressure type: **AS1.5P80**...

2.2.5 HYDRAULIC LINE SHOCK DAMPER WITH BLADDER ACCUMULATOR

A rapid increase in pressure caused by a high acceleration or deceleration in flow is commonly known as water hammer. The overpressure, ΔP max, that takes place in piping, the flow rate, the density of the liquid and the valve shut down time.

This is given by:

$$\Delta P \text{ max (bar)} = 2 Y L v / t \times 10^5$$

The volume of the accumulator, required to reduce shock pressure within predetermined limits ΔP , is obtained by:

$$V_0 = Q/7.2 (2 Y L v / C_0 \times 10^5 - t) / (P_0/P_1)^{0.7143} - (P_0/P_2)^{0.7143}$$

Where:

- V_0 = accumulator gas capacity (litres)
- Q = flow rate in the piping (m^3/h)
- L = total length of piping (m)
- Y = specific gravity of the fluid (kg/m^3)
- V = $Q/S \times 103/3.6$ = flow velocity (m/s)
- S = $\pi d^2 / 4$ = internal pipe section (mm^2)
- d = internal pipe diameter (mm)
- ΔP = allowable overpressure (bar)
- P_1 = operating pressure by free flow (absolute bar)
- P_2 = $P + \Delta P$ = max allowable pressure (absolute bar)
- t = deceleration time (s) (valve shut down, etc.)

Example:

Assume a water pipe ($Y = 1000 \text{ kg/m}^3$) with internal diameter $d = 80 \text{ mm}$, length $L = 450 \text{ m}$, flow rate $Q = 17 \text{ m}^3/h$, operating pressure $P_1 = 5 \text{ bar}$, allowable overpressure $\Delta P = 2 \text{ bar}$, valve closure time $t = 0.8 \text{ s}$.

$$\Delta P \text{ max} = 2 \times 1000 \times 450 \times 0.94 / 0.8 \cdot 10^5 = 10.57 \text{ bar}$$

The accumulator volume necessary to reduce the ΔP max to 2 bar is:

$$V_0 = 17/7.2 (2 \times 1000 \times 450 \times 0.94 / 2 \times 10^5 - 0.8) / (5.5/6)^{0.7143} - (5.5/8)^{0.7143} = 46.4 \text{ l}$$

Where:

- $S = \pi \times 80^2 / 4 = 5026.5 \text{ mm}^2$
- $V = 17 \times 103 / 5026.5 \times 3.6 = 0.94 \text{ m/s}$
- $P_0 = 5 \times 0.9 = 4.5 = 5.5 \text{ abs. bar}$
- $P_1 = 6 \text{ abs. bar}$
- $P_2 = 5 + 2 = 7 \text{ bar} = 8 \text{ abs. bar}$

An accumulator of 55 litres low pressure range will be chosen, type **AS55P30**...

2.2.6 PISTON ACCUMULATOR + ADDITIONAL GAS BOTTLES (TRANSFER)

In all case where a considerable amount of fluid must be obtained with a small difference between P_1 and P_2 , the resultant volume V_0 is large compared to ΔV .

In these cases, it could be convenient to get the required nitrogen volume by additional bottles. Volume calculation is performed, according to the application, both in isothermal as well as in adiabatic conditions, using the formulas given above always taking temperature into account. To get the maximum of efficiency, it is convenient to fix a quite high pre-charge value. In case of **energy reserve**, it is possible to use:

$$P_0 = 0.97 P_1 \quad \text{or} \quad P_0 = P_1 - 5$$

Once the required gas volume is calculated, the volume must be allocated between the minimum indispensable portion V_A , which represents the volume of additional bottles.

$$V_{oT} = V_{oA} + V_{oB}$$

Where:

$$V_{oA} \geq \Delta V + (V_{oT} - V_0) / 0.75$$

This means that the sum of the required fluid volume plus the volume change due to temperature must be **lower than 3/4 of the accumulator capacity**. The bottles volume is given by the difference.

$$V_{oB} = V_{oT} - V_{oA}$$

Example:

Suppose $\Delta V = 30 \text{ l}$. to be obtained in 2 seconds, from a pressure $P_2 = 180 \text{ bar}$ to $P_1 = 160 \text{ bar}$.

Temperature: $q_1 = 20^\circ\text{C}$; $q_2 = 45^\circ\text{C}$

$$P_{0(45^\circ\text{C})} = 0.97 \times 160 = 155 \text{ bar}$$

$$V_0 = \Delta V / (P_0/P_1)^{0.7143} - (P_2/P_1)^{0.7143} \\ = 30 / (156/161)^{0.7143} - (156/181)^{0.7143} = 382.4 \text{ l}$$

$$V_{oT} = 382.4 \times 318 / 293 = 415 \text{ l}$$

$$V_{oA} = 30 + (415 - 382.4) / 0.75 = 83.5 \text{ l}$$

One accumulator **AP100**... is used with the total $V_0 = 100 \text{ l}$. plus **6 bottles of 50 l.** type **B52P360**... or 4 additional bottles type **B75P360**... of 75 l.

Reproduction is forbidden.

In the spirit of continuous improvement, our products may be changed.



BLADDER ACCUMULATORS type AS and ASP

3.1



BLADDER ACCUMULATORS LIQUID SEPARATOR
type ASL and TRANSFER type AST

3.2



BLADDER ACCUMULATORS LOW PRESSURE type ASB

3.3



BLADDER ACCUMULATORS LOW PRESSURE LIQUID
SEPARATOR type ASBL and TRANSFER type ASBT

3.4



BLADDER ACCUMULATORS ASME U-stamp type ASA

3.5



BLADDER ACCUMULATORS LARGE VOLUMES type ASE

3.6



SPARE BLADDERS AND VALVES type S

3.7

3.1.1 TECHNICAL DATA

MAX OPERATING PRESSURE (PS): 360 bar

PRESSURE TEST (PT): 1.43 x PS

NOMINAL CAPACITIES:

0.2 - 0.7 - 1 - 1.5 - 3 - 5 - 10 - 15 - 20 - 25 - 35 - 55 litres

WORKING TEMPERATURE: -40 ÷ +150 °C

COMPRESSION RATIO (Po : P2): max. 1 : 4

FLUID VISCOSITY RANGE: 10 ÷ 400 cSt

RECOMMENDED VISCOSITY: 36 cSt

FLUID CONTAMINATION DEGREE:

class 21/19/16 according to ISO 4406/99

BODY MATERIAL:

- carbon steel shell painted with rust inhibitor RAL 8012
- nickel coating 25 - 40 µ
- stainless steel AISI 316L
- internal and external coating with RILSAN th. 0.6 mm

VALVES MATERIAL:

- phosphated or galvanized carbon steel in compliance with Directive 2002/95/EC (RoHS) to resist to corrosion
- stainless steel AISI 316L
- nickel coating 25-40 µ

BLADDER MATERIAL:

- P = Nitrile rubber (NBR)
- F = Low temp. nitrile rubber
- H = Nitrile for hydrocarbons
- K = Hydrogenated nitrile (HNBR)
- B = Butyl (IIR)
- E = Ethylene-propylene (EPDM)
- N = Chloroprene (Neoprene)
- Y = Epichlorohydrin (ECO)
- V = Fluorocarbon (FPM)

See Table 3.1c and/or Chapter 1.5

FILLING VALVE CONNECTION:

- 5/8" UNF std
- 7/8" UNF
- 1/4" BSP

FLUID PORT CONNECTION: see 3.1dc - 3.1df -

3.1eb - 3.1ec - 3.1fb - 3.1fd

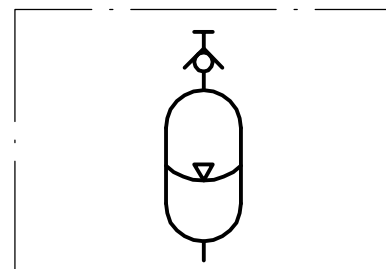
FLOW RATE: see Table 3.1db

WEIGHT: see Table 3.1db - 3.1df



3.1a

3.1.2 HYDRAULIC SYMBOL



3.1b

3.1.3 “AS and ASP” BLADDER ADVANTAGES

- dirt tolerant
- light weight
- compact
- simple construction
- quick response
- works well on water, low lubricity fluids
- quick, easy installation
- low cost

3.1.4 DESCRIPTION

Bladder-type accumulators consist of a seamless cylindrical pressure vessel made of high-tensile steel.

The accumulator is subdivided into a gas and fluid side by an elastic bladder mounted in the interior of the vessel.

The bladder is charged with nitrogen to the specified gas charge pressure P0 by means of gas valve.

When the fluid is pressed into the accumulator, the gas in the bladder is compressed and hence the pressure increased.

The gas volume reduces and on the fluid side, the fluid can flow into the accumulator. As soon as the pressure on the fluid side falls below the gas pressure, the accumulator is emptied.

Oil valve is provided in the oil port of the bladder-type accumulator and closes when the pressure on the gas side is higher than the one on the fluid side.

This prevents draining of the bladder into the oil channel and thus the bladder from being destroyed.

When the minimum operating pressure is reached, a small oil volume is to be maintained between the bladder and the fluid volume (approx. 10% of the nominal capacity of the hydraulic accumulator), in order that the bladder does not hit the valve during every expansion process.

Gas valve consists of external caps, sealing cap, filling valve, gas valve body and rubber coated washer. These parts can be replaced separately. The nameplate shows the technical data and features of the hydraulic accumulator.

3.1.5 EUROPE MARKET

All hydraulic accumulators are pressure vessels and are subject to the national regulations and directives valid at the place of installation. Bladder accumulator type AS, up to and including 1 litre, must not be CE marked.

Bladder accumulator type ASP, up to and including 1 litre and max. pressure less than 200 bar, must not be CE marked.

For bladder accumulator type AS, greater than 1 litre and, in the case of ASP, greater than 1 litre but with max. pressure higher than 200 bar every shipping batch is complete of a conformity declaration and instruction of use and maintenance and/or all documents requested.

All vessel categories (see Table 3.1e) must be protected by means of a pressure relief valve in accordance with Directive 97/23/EC.

3.1.6 ACCESSORIES

For support equipment, see Cap. 7

For gas side's safety equipment, see Cap. 8

For fluid side's safety equipment, see Cap. 9

For pre-loading and charging set, see Cap. 11

For other components, see Cap. 12

3.1.7 BLADDER-TEMPERATURE-LIQUID COMPATIBILITY

When selecting the accumulator variant, pay attention to the following non-binding notes with regard to hydraulic fluid, bladder material and the permissive temperature range. (see Section 1.5)

Code letter	Polymer	ISO	Temperature range (°C)	Some of the liquids compatible with the polymer
P	Standard nitrile (Perburan)	NBR	-20 ÷ +80	Aliphatic hydrocarbons (propane, butane, gasoline, oils, mineral greases, diesel fuel, fuel oil, kerosene), mineral greases and oils, HFA - HFB - HFC fluids, many dilute acids, alkalis, saline solutions, water, water glycol.
F	Low temperature nitrile	NBR	-40 ÷ +70	The same as with standard nitrile + a number of different types of Freon. (This contains less acrylonitrile than the standard and is therefore more suitable for low temperatures, but its chemical resistance is slightly lower).
H	Nitrile for hydrocarbons	NBR	-10 ÷ +90	Regular and premium grade slightly aromatic gasoline (and all the liquids for standard nitrile).
K	Hydrogenated nitrile	HNBR	-30 ÷ +130	The same as with standard nitrile but with excellent performance at high and low temperatures.
B	Butyl	IIR	-30 ÷ +100	Hot water up to 100°C, glycol-based brake fluids, many acids and bases, salt solutions, polar solvents such as alcohols, ketones and esters, polyglycol-based hydraulic fluids (HFC fluids) and bases of esters of phosphoric acid (HFD-R fluids), silicone oils and greases, Skydol 500 and 7000, resistance to ozone, aging and weathering.
E	Ethylene-Propylene	EPDM	-30 ÷ +100	Hot water up to 100°C, glycol-based brake fluids, many organic and inorganic acids, detergents, solutions of sodium and potassium, phosphate ester-based hydraulic fluids, (HFD-R), silicone oils and greases, many polar solvents (alcohol, ketones, esters), Skydol 500 and 7000, resistance to ozone, aging and weathering.
N	Chloroprene (Neoprene)	CR	-30 ÷ +100	Mineral oils of paraffin, silicone oils and greases, water and aqueous solutions, refrigerants (ammonia, carbon dioxide, Freon), naphthenic mineral oils, low molecular aliphatic hydrocarbons (propane, butane, fuel), brake fluids based on glycol, better resistance to ozone, weathering and aging compared to NBR rubber.
Y	Epichloridrin	ECO	-30 ÷ +110	Mineral oils and greases, aliphatic hydrocarbons (propane, butane and gasoline), silicone oils and greases, water at room temperature, resistance to ozone, aging and weathering.
V	Fluorocarbon	FPM	-10 ÷ +150	Mineral oils and greases, non-flammable fluids of HFD group, silicone oils and greases, animal and vegetable oils and greases, aliphatic hydrocarbons (gasoline, butane, propane, natural gas), aromatics hydrocarbons (benzene, toluene), chlorinated hydrocarbons (Tetrachloroethylene, carbon tetrachloride), fuel (regular, super and containing methanol), excellent resistance to ozone, weathering and aging.

For other hydraulic fluid and/or temperatures, please consult us.

3.1c

3.1.8 ORDER CODE

1	2	3	4	5	6	7-8	9	10	11	12	13	14	15	16	
AS	25	P	360	C	R	G4	V	-	8	-	C	0	C	0	R250 / 30

<p>1 Series</p> <p>Bladder accumulator = AS Bladder accumulator for fluid gr. 1 (dangerous) = ASP</p> <p>2 Nominal capacity</p> <p>0.2 lt = 0.2 0.7 lt = 0.7 1 lt = 1 1.5 lt = 1.5 3 lt = 3 5 lt = 5 10 lt = 10 15 lt = 15 20 lt = 20 25 lt = 25 35 lt = 35 55 lt = 55</p> <p>3 Bladder material</p> <p>Nitrile rubber (NBR) = P Nitrile for low temp. = F Nitril for hydrocarbons = H Hydrogenated nitrile (HNBR) = K Butyl (IIR) = B Ethylene-propylene (EPDM) = E Chloroprene (Neoprene) = N Epichlorohydrin (ECO) = Y Fluorocarbon (FPM) = V</p> <p>4 Max working pressure (PS)</p> <p>See the table on front page</p> <p>5 Body material</p> <p>Carbon steel = C Nickel coated carbon steel 25 μ = N Nickel coated carbon steel 40 μ = M Stainless steel = X Rilsan coating = V</p> <p>6 Fluid port connection</p> <p>See the table on front page</p> <p>7-8 Dimension of the connection fluid or 7+8 table</p> <p>See the table on front page</p>	<p>16 Precharge pressure (bar)</p> <p>Standard 30 bar = 0 ÷ 300 (< PS)</p> <p>15 Other variants</p> <p>See the table on front page</p> <p>14 Variants of gas side</p> <p>Standard = 0 Only cap in stainless steel = 1 Brass nameplate = 2 Other numbers/variants to be requested EPE</p> <p>13 Gas valve material</p> <p>Carbon steel = C Nickel coated carbon steel 25 μ = N Nickel coated carbon steel 40 μ = M Stainless steel = X</p> <p>12 Variants of fluid side</p> <p>Standard = 0 Adapter in stainless steel (R) = 1 Button and spring in stainless steel = 2 Other numbers/variants to be requested EPE</p> <p>11 Fluid valve material</p> <p>Carbon steel = C Nickel coated carbon steel 25 μ = N Nickel coated carbon steel 40 μ = M Stainless steel = X</p> <p>10 Test and certification</p> <p>Factory testing = 0 TR (Russia) = 1 Australian Standard = 2 ML (China) = 3 RINA = 4 PED97/23/EC (for capacities greater than 1 l) = 8 ATEX 94/9EC = 9 DNV = 10 RTN Passport (Ukraine) = 11 Algeria passport = 12 Standard regulation (NR13) (Brazil) = 13 Tunisia passport = 14</p> <p>9 Type of filling valve</p> <p>Standard filling valve 5/8" UNF thread = V Standard filling valve with 5/8" UNF thread in stainless steel = VX Without filling valve (thread hole M12x1.5) = VO Brass filling valve 1/4" BSP = V2 Filling valve 7/8" UNF = V4</p>
--	---

Special variants upon request

4 Max working pressure (PS)		
Capacity litres	Carbon steel	Stainless steel
0,2 ÷ 3	360 (100 only for ASP type)	150 - 210 - 360
1 ÷ 3	343 (for Certification RINA [4])	-
5 ÷ 55	360 (100 only for ASP type: 210 only for the version with connection L or other pressure related to connections B or U)	80 - 150 - 210 -360
5 ÷ 55	343 (for Certification RINA [4])	-

6 Fluid port connection		
For AS0.7÷55	BSP ISO 228 with chamfer for OR (std)	= A
For AS0.2	BSP ISO 228 (std)	= G
For AS3+55	Metric	= M
For AS0.7÷55	NPT-F	= P
For AS3+55	internal thread SAE	= S
For AS3+55	adapter for flange SAE 3000 Psi	= L
For AS3+55	adapter for flange SAE 6000 Psi	= H
For AS0.7÷55	flange ANSI	= B
For AS0.7÷55	flange UNI - DIN	= U
For AS0.7÷55	square flange	= Q
For AS0.7÷55	adapter *	= R

* assembled on the fluid valve connection type A

7 Dimension of the fluid connection		
For the type of connection:		
A (0.7÷1.5 l) ¾"		= 5
(3÷5 l) 1" ¼"		= 7
(10÷55 l) 2"		= 9
G (0.2 l) ½"		= 4
M (3÷5 l) 40x1.5		= 40/1.5
(10÷55 l) 50x1.5		= 50/1.5
P (0.7÷1.5 l) ¾"		= 5
(3÷5 l) 1" ¼"		= 7
(10÷55 l) 2"		= 9
S (0.7÷1.5 l) 1" 1/16 12UN		= 1 1/16-12
(3÷5 l) 1" 5/8 12UN		= 1 5/8-12
(10÷55 l) 1" 7/8 12UN		= 1 7/8-12
L (3÷5 l) 1" ¼ SAE3000		= 7
(10÷55 l) 1" ½ SAE 3000		= 8
2" SAE 3000		= 9
H (3÷5 l) 1" ¼ SAE6000		= 7
(10÷55 l) 1" ½ SAE 6000		= 8
2" SAE 6000		= 9
B (0.7÷55 l)	DIMENSION/RATING	
Former. 1" ANSI 1500 = 1/1500 (Pmax = 250 bar)		
U (0.7÷55 l)	DN/PN	
Former. DN50 PN100 = 50/100 (Pmax = 100 bar)		
Q (3÷5 l) 1" ¼		= 7
(10÷55 l) 2"		= 9
R (0.7÷55 l) Blind		= 0
R (0.7÷55 l) internal thread	BSP ISO 228	= G*
	NPT-F	= P*
	BSPT	= N*
	SAE	= S*
	Metric	= M*

*Variant in table 8

15 Other variants	
Adapter + rupture disc set at xxx bar	= Rxxx
(see Section 8.2)	
Adapter + Safety valve, type VS224/TX set at xxx bar	= Gxxx
Adapter + Needle Valve of ¼" BSP	= EG2
Adapter + Stainless steel needle Valve of ¼" BSP	= EG2X
Adapter + excluding device with with full scale pressure gauge of xxx bar	= EMxxx
Adapter + excluding device of 90° with full scale pressure gauge of xxx bar	= ELMxxx
Flushing with degree of contamination ≤ x	= Fx
75-80 µ thick polyurethane paint with colour to be specified	= Wxxx
Off-shore paint with colour to be specified	= Zxxx
NORSOK System 1 paint with colour to be specified	= K1
NORSOK System 7 paint with colour to be specified	= K7
other variants upon request	

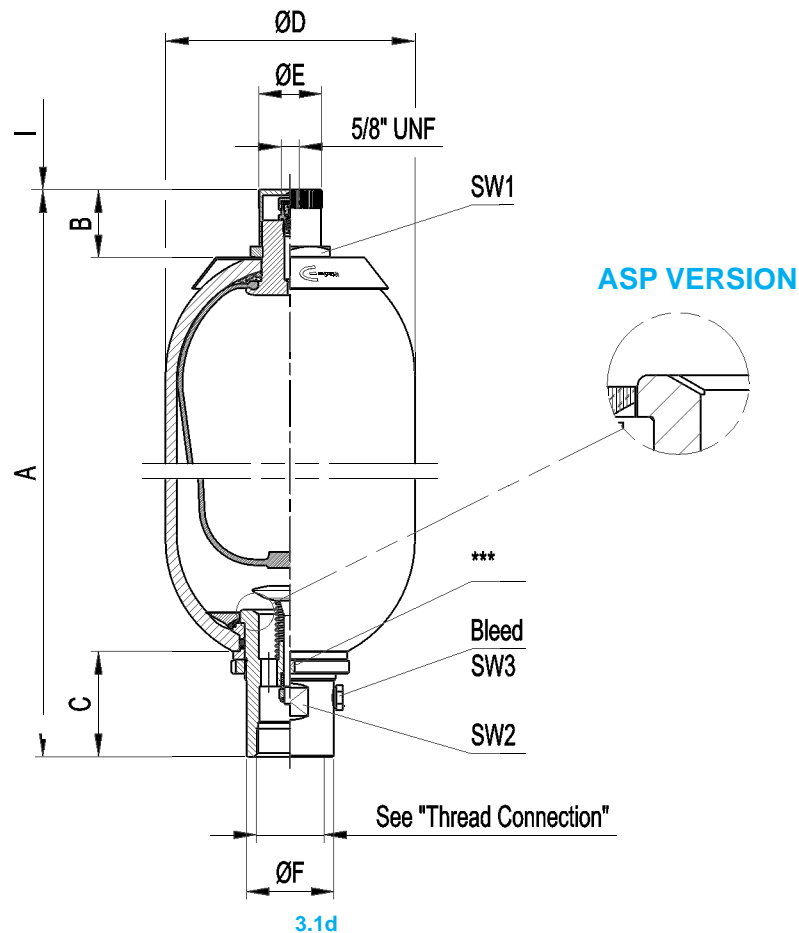
8 Dimension			
1/8"	= 1	4/4"	= 5
1/4"	= 2	1"	= 6
3/8"	= 3	1" ¼"	= 7
1/2"	= 4	1" ½"	= 8

Dimension in inch - No. of pitch for inch

Diameter/pitch

Special variants on request

3.1.9 DIMENSIONS



Acc. type AS-ASP in carbon steel	Nominal gas volume litres	Effective gas volume litres	Working pressure bar	Ped. cat. fluids of group 2 AS	Ped. cat. fluids of group 1 ASP	Max.diff. pressure P2-P1 bar	Flow rate l/min	Max.comp. ratio P0/P2	A mm	B mm	C mm	ØD mm	ØE mm	ØF mm	I mm	SW 1 mm	SW 2 mm	SW 3 mm	Bleed	Acc. dry weight kg
AS/ASP 0,2	0,2	0,2	360	Art.3 (3)	III	100	160	1:4	252 ± 2	23	40	53	20	26	140	24	23	4*	M5	1,7
AS/ASP 0,7	0,7	0,65	360	Art.3 (3)	III	100	300	1:4	280 ± 1,5	47	52	90	25	36	140	32	32	4*	M5	4,2
AS/ASP 1	1	1	360	Art.3 (3)	III	100	300	1:4	296 ± 5	47	52	114	25	36	140	32	32	4*	M5	5,2
AS/ASP 1,5	1,5	1,5	360	II	III	100	300	1:4	355 ± 5	47	52	114	25	36	140	32	32	4*	M5	6,3
AS/ASP 3	3	2,95	360	III	IV	100	600	1:4	554 ± 8	47	65	114	25	53	140	32	50	4*	M5	11
AS/ASP 5	5	5	360	III	IV	100	600	1:4	458 ± 10	47	65	168	25	53	140	32	50	4*	M5	15
AS/ASP 10	10	9,1	360	IV	IV	100	1000	1:4	569 ± 10	60	101	220	60	77	140	70	70	19**	1/4" BSP	33
AS/ASP 15	15	14,5	360	IV	IV	100	1000	1:4	719 ± 10	60	101	220	60	77	140	70	70	19**	1/4" BSP	43
AS/ASP 20	20	18,2	360	IV	IV	100	1000	1:4	879 ± 10	60	101	220	60	77	140	70	70	19**	1/4" BSP	48
AS/ASP 25	25	23,5	360	IV	IV	100	1000	1:4	1044 ± 15	60	101	220	60	77	140	70	70	19**	1/4" BSP	59
AS/ASP 35	35	33,5	360	IV	IV	100	1000	1:4	1393 ± 15	60	101	220	60	77	140	70	70	19**	1/4" BSP	78
AS/ASP 55	55	50	360	IV	IV	100	1000	1:4	1904 ± 15	60	101	220	60	77	140	70	70	19**	1/4" BSP	108

* Allen wrench

** Ex. wrench

*** see chapter 3.1.12.2 table 3.1ab

3.1db

* The maximum differential pressure is the maximum allowable difference between the maximum pressure and the minimum working pressure (P2-P1) to have an infinite life cycle of the accumulator (greater than 2,000,000 cycles).

** Flow rate measured using mineral oil with viscosity of 36 cSt at 50°C and ΔP = 5 bar

3.1.9.1 STANDARD THREAD CONNECTIONS

Dimensions	Connection Type	Accumulator type	Complete spare valve order code	Ød	ØD mm	ØF mm	H mm	
	A BSP ISO 228 with chamfer for OR	AS/ASP 0,2	-	-	-	-	-	
		AS/ASP 0,7	V 2023-A5-**/*	3/4" BSP	28,8	36	19	
		AS/ASP 1	V 2024-A5-**/*					
		AS/ASP 1,5						
		AS/ASP 3	V 2025-A7-**/*	1" 1/4 BSP	46	53	25	
		AS/ASP 5	V 2044-A7-**/*					
		AS/ASP 10 ÷ 55	V 2064-A9- **/*	2" BSP	63,35	77	28	
	G BSP ISO 228	AS/ASP 0,2	V 2004-G4-**/*	1/2" BSP	-	26	15	
		AS/ASP 0,7	-	-	-	-	-	
		AS/ASP 1	-	-	-	-	-	
		AS/ASP 1,5	-	-	-	-	-	
		AS/ASP 3	-	-	-	-	-	
		AS/ASP 5	-	-	-	-	-	
		AS/ASP 10 ÷ 55	-	-	-	-	-	
	M Metric	AS/ASP 0,2	-	-	-	-		
		AS/ASP 0,7						
		AS/ASP 1						
		AS/ASP 1,5						
		AS/ASP 3	V 2025-M40x1.5-**/*	M40x1,5	-	53	25	
		AS/ASP 5	V 2044-M40/1.5-**/*					
AS/ASP 10 ÷ 55	V 2064-M50/1.5-**/*	M50x1,5	-	77	28			
	P NPT-F	AS/ASP 0,2	-	-	-	-		
		AS/ASP 0,7					V 2023-P5-**/*	
		AS/ASP 1					V 2024-P5-**/*	
		AS/ASP 1,5						
		AS/ASP 3	V 2025-P7-**/*	1" 1/4 NPT-F	-	53	Thread plug gage	
		AS/ASP 5	V 2044-P7-**/*	2" NPT-F	-	77		
AS/ASP 10 ÷ 55	V 2064-A9- **/*							
	S SAE thread	AS/ASP 0,2	-	-	-	-		
		AS/ASP 0,7					V 2023-S1 /16-12-**/*	
		AS/ASP 1					V 2024-S1 /16-12-**/*	
		AS/ASP 1,5						
		AS/ASP 3	V 2025-S1 5/8-12-**/*	1" 5/8 12 UN	43,5	53	23	
		AS/ASP 5	V 2044-S1 5/8-12-**/*					
		AS/ASP 10 ÷ 55	V 2064-S1 7/8-12-**/*	1" 7/8 12 UN	49,84	77	26	

* Gasket material

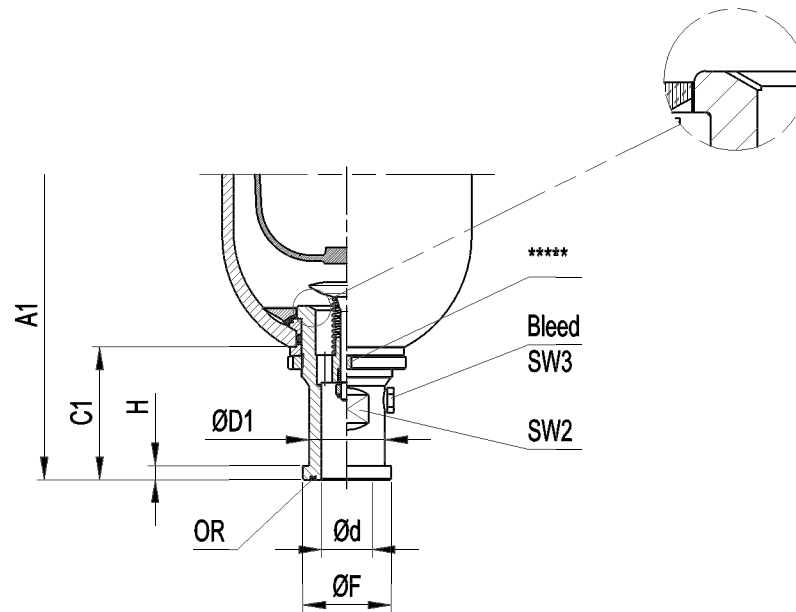
** Component material

For "ASP" version valve order code become V xxxxP - thread version

3.1dc

3.1.9.2 ADAPTER FOR FLANGE SAE 3000/6000 PSI (L/H)

ASP VERSION



3.1de

Acc. type AS-ASP in carbon steel	Dim.	A1 mm	C1 mm	SW2 mm	SW3 mm	Bleed	Ød mm	SAE 3000 (L)				SAE6000 (H)				OR (Included)	Acc. dry weight kg
								Spare valve order code	ØD1 mm	ØF mm	H mm	Spare valve order code	ØD1 mm	ØF mm	H mm		
AS / ASP 0,2	-	-	-	-	-	-	-	-	-	-	-	-	-	-	-	-	-
AS / ASP 0,7	-	-	-	-	-	-	-	-	-	-	-	-	-	-	-	-	-
AS / ASP 1	-	-	-	-	-	-	-	-	-	-	-	-	-	-	-	-	-
AS / ASP 1,5	-	-	-	-	-	-	-	-	-	-	-	-	-	-	-	-	-
AS / ASP 3	1"	589 ± 8	100	38	4***	M5	-	-	-	-	-	V 2025-H6-***	38	47,6	9,5	0010R4131-*	11
	1 1/4"	578 ± 8	89				31	V 2025-L7-***	43	50,8	8	V 2025-H7-***	44	53,3	10,3		
AS / ASP 5	1"	493 ± 10	100	38	4***	M5	-	-	-	-	-	V 2044-H6-***	38	47,6	9,5	0010R4131-*	15
	1 1/4"	482 ± 10	89				31	V 2044-L7-***	43	50,8	8	V 2044-H7-***	44	53,3	10,3		
AS / ASP 10	1 1/2"	583 ± 10	115	42	19****	1/4"	32	V 2064-L8-***	50	60,3	8	V 2064-H8-***	51	63,5	12,5	0010R4187-*	33
	2"						45	V 2064-L9-***	62	71,5	9,5	V 2064-H9-***	67	77,6			
AS / ASP 15	1 1/2"	733 ± 10	115	42	19****	1/4"	32	V 2064-L8-***	50	60,3	8	V 2064-H8-***	51	63,5	12,5	0010R4187-*	43
	2"						45	V 2064-L9-***	62	71,5	9,5	V 2064-H9-***	67	77,6			
AS / ASP 20	1 1/2"	893 ± 10	115	42	19****	1/4"	32	V 2064-L8-***	50	60,3	8	V 2064-H8-***	51	63,5	12,5	0010R4187-*	48
	2"						45	V 2064-L9-***	62	71,5	9,5	V 2064-H9-***	67	77,6			
AS / ASP 25	1 1/2"	1058 ± 15	115	42	19****	1/4"	32	V 2064-L8-***	50	60,3	8	V 2064-H8-***	51	63,5	12,5	0010R4187-*	59
	2"						45	V 2064-L9-***	62	71,5	9,5	V 2064-H9-***	67	77,6			
AS / ASP 35	1 1/2"	1408 ± 15	115	42	19****	1/4"	32	V 2064-L8-***	50	60,3	8	V 2064-H8-***	51	63,5	12,5	0010R4187-*	78
	2"						45	V 2064-L9-***	62	71,5	9,5	V 2064-H9-***	67	77,6			
AS / ASP 55	1 1/2"	1918 ± 15	115	42	19****	1/4"	32	V 2064-L8-***	50	60,3	8	V 2064-H8-***	51	63,5	12,5	0010R4187-*	108
	2"						45	V 2064-L9-***	62	71,5	9,5	V 2064-H9-***	67	77,6			

* Gasket material ** Component material *** Allen wrench **** Ex. Wrench ***** see chapter 3.1.12.2 table 3.1ab

For "ASP" version valve order code become V xxxxP - thread version

3.1df

3.1.9.3 FLANGE CONNECTION TYPE ANSI / UNI DIN (B/U)

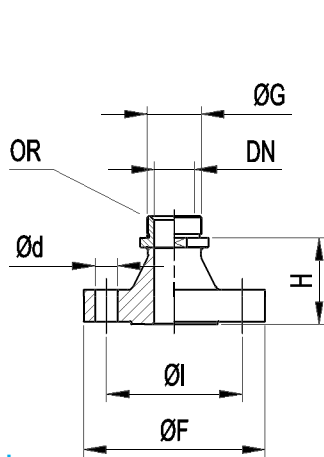


Fig. I

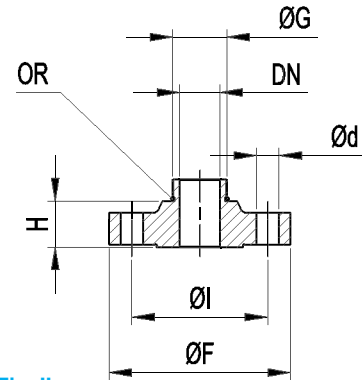
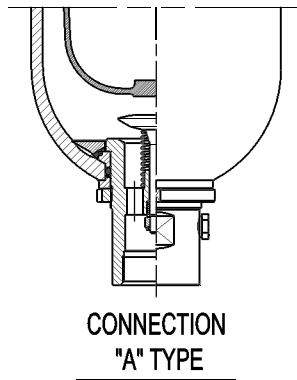


Fig. II

3.1ea

	Accumulator type	Spare flange order code	Ref. Directive		DN mm	PN bar	Fig.	Ø F mm	Ø I mm	Ø d mm	N° Holes	H mm	G BSP	OR (Included)
			UNI	DIN										
U (UNI-DIN)	AS / ASP 0,7 - 1 - 1,5	F 2205 - ** / *	2284	2635	20	40	II	105	75	14	4	23	3/4"	0010R2093-*
		F 2206 - ** / *	6086	2628		250		135	95	18	4	45		
	AS / ASP 3 - 5	F 2211 - ** / *	2284	2635	25	40	I	115	85	14	4	51	1 1/4"	0010R3150-*
		F 2212 - ** / *	6086	2628		250		150	105	22	4	76		
		F 2215 - ** / *	2284	2635	32	40	II	140	100	18	4	22		
		F 2216 - ** / *	6086	2628		250		165	120	22	4	55		
	AS / ASP 10 ÷ 55	F 2221 - ** / *	2282	2633	25	16	I	115	85	14	4	49	2"	0010R3218-*
		F 2222 - ** / *	2284	2635		40		115	85	14	4	51		
		F 2223 - ** / *	6086	2628		250		150	105	22	4	76		
		F 2227 - ** / *	2284	2635	40	40	I	150	110	18	4	56		
		F 2228 - ** / *	6086	2628		250		185	135	25	4	91		
		F 2231 - ** / *	2282	2633	50	16	II	165	125	18	4	23		
		F 2232 - ** / *	2285	2636		64		185	135	22	4	40		
		F 2233 - ** / *	6086	2628		250		200	150	25	8	61		

* Gasket material

** Flange material

Others size on request

3.1eb

	Accumulator type	Spare flange order code	Ref. Directive	DN inch	PN lbs	Fig.	Ø F mm	Ø I mm	Ø d mm	N° Holes	H mm	G BSP	OR (Included)
F 2208 - ** / *	B16.5	1500	130	88,9	22,5	4	59						
AS / ASP 3 - 5	F 2213 - ** / *	B16.5	1"	300	I	123,5	88,9	22,5	4	73	1 1/4"	0010R3150-*	
	F 2214 - ** / *	B16.5		1500		149,5	101,6	25,4	4	90			
	F 2217 - ** / *	B16.5	1 1/4"	300	II	133,3	98,4	19	4	44			
	F 2218 - ** / *	B16.5		1500		159	111,1	25,4	4	58			
AS / ASP 10 ÷ 55	F 2225 - ** / *	B16.5	1"	300	I	123,5	88,9	19	4	73	2"	0010R3218-*	
	F 2226 - ** / *	B16.5		1500		149,5	101,6	25,4	4	90			
	F 2229 - ** / *	B16.5	1 1/2"	300	I	155,6	114,3	22,2	4	79			
	F 2230 - ** / *	B16.5		1500		178	123,8	28,5	4	100			
	F 2235 - ** / *	B16.5	2"	400	II	165	127	19	8	55			
	F 2236 - ** / *	B16.5		1500		216	165,1	25,4	8	83			

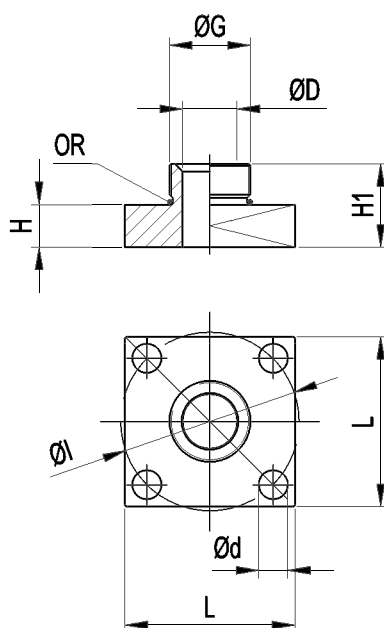
* Gasket material

** Flange material

Others size on request

3.1ec

3.1.9.4 SQUARE FLANGE CONNECTION



3.1fa

Accumulator type	Spare square flange order code	α G BSP	Ø D mm	L mm	Ø l mm	H mm	Ø d mm	H 1 mm	Weight Kg	OR (Included)
AS / ASP 3 - 5	F 2454 A7 - ** / *	1" 1/4 BSP	26	100	105	25	17.5	49	0,8	0010R3150 - *
AS / ASP 10 ÷ 55	F 2455 A9 - ** / *	2" BSP	32						0,9	0010R3218 - *

* Gasket material

** Square flange material

Weight indicated only for blind version

3.1fb

3.1.9.5 ADAPTERS

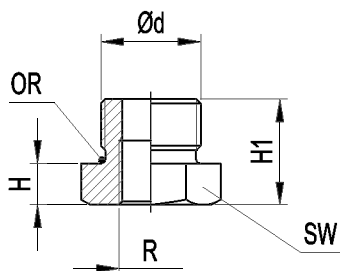


Fig. I

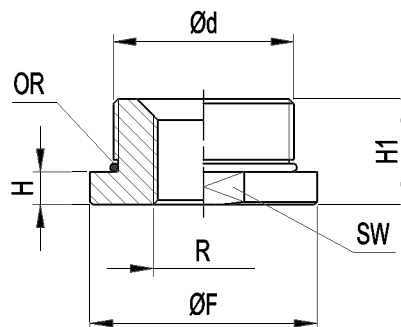


Fig. II

3.1fc

Accumulator type	Order code	Ød Acc. connection	R**** Out connections (0 = blind)	Fig.	SW mm	Ø F mm	H mm	H1 mm	OR (Included)	Weight Kg
AS / ASP 0,7 - 1 - 1,5	R - A5*** - ** / *	3/4" BSP	1/8" ÷ 3/8" BSP - NPT - BSPT	I	32	-	11	28	0010R2093 - *	0,14
			1/2" BSP - NPT - BSPT	I			28	45		0,27
AS / ASP 3 - 5	R - A7*** - ** / *	1" 1/4 BSP	1/8" ÷ 1" BSP - NPT - BSPT	II	48	53	11	32	0010R3150 - *	0,41
AS / ASP 10 ÷ 55	R - A9*** - ** / *	2" BSP	1/8" ÷ 1" 1/2 BSP - NPT - BSPT	II	70	75	11	35	0010R3218 - *	0,86

* Gasket material

** Adapter material

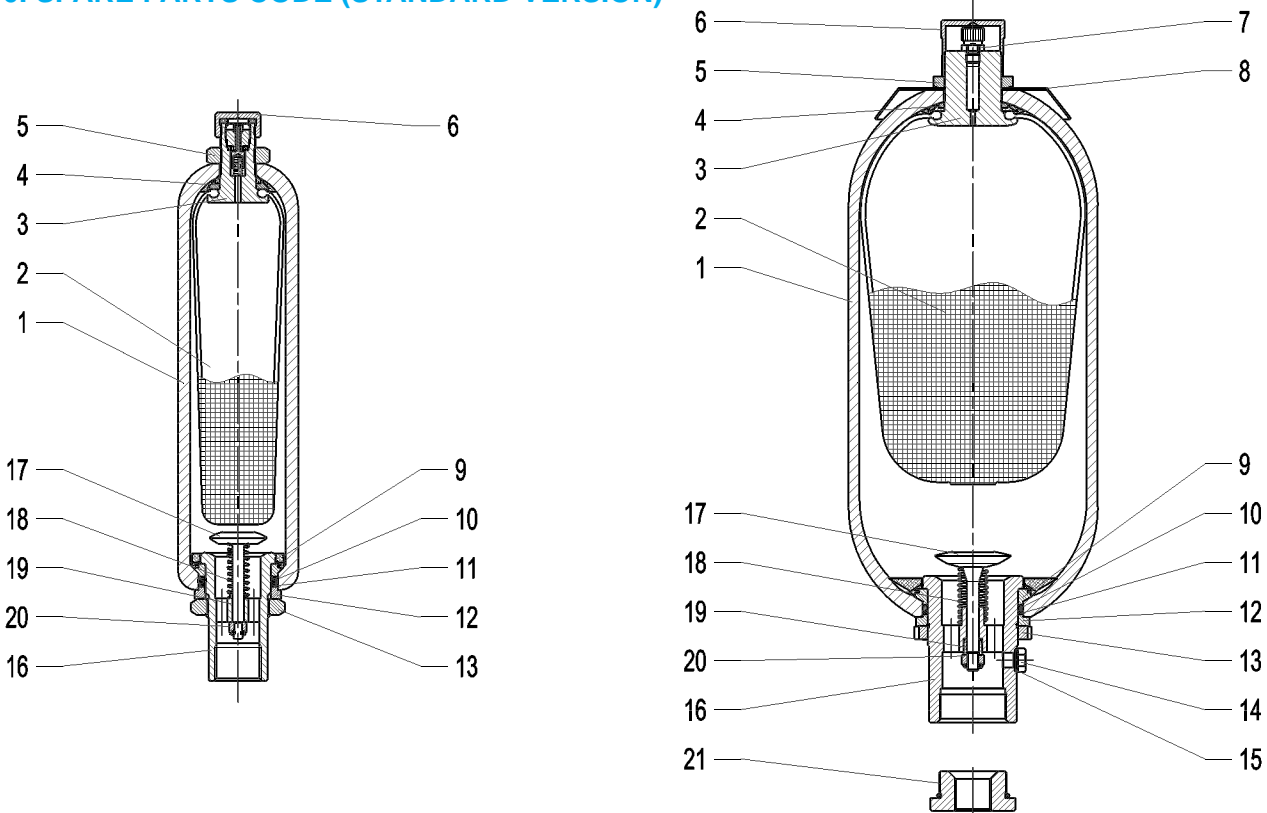
*** See chapter 3.1.8 table 7 - 8

Weight indicated only for blind version

3.1fd

**** R Out connections type "S" and "M" thread on request

3.1.10. SPARE PARTS CODE (STANDARD VERSION)



3.1ga

Item	Description	Q.ty	Type						
			AS / ASP 0,2	AS / ASP 0,7	AS / ASP 1 - 1,5	AS / ASP 3	AS / ASP 5	AS / ASP 10 ÷ 55	
1	Accumulator shell	1	Not supplied as spare part						
2	Bladder	1	S 0.2* - 0	S0.7* - 0	S1* - 0 / S1.5* - 0	S3* - 0	S5* - 0	S10 ÷ 55* - 0	
3	Gas valve body	1	B10026 - **	B10107 - **			B10202 - **	B10333 - **	
4	Rubber-coated washer	1	B10024 - ** / *	B10104 - ** / *	B10106 - ** / *		B10205 - ** / *	B10334 - ** / *	
5	Gas valve looknut	1	B10023 - **		B10109 - **			B10302 - **	
6	Protection cap	1	B10337 / 00 - ** - *		B10103 - **			B10301 - **	
7	Gas-fill valve	1	V 2001 - ** / *						
8	Name plate	1	D10300A-A			D10300C-A		D10300E-A	
9	Retaining ring	1	B10035 - ** / *	B10123 - ** / *	B10127 - ** / *	B10146 - ** / *	B10222 - ** / *	B10317 - ** / *	
10	"O" ring	1	0010R4112 - *	0010R4150 - *		0010R0159 - *	0010R6212 - *	0010R0181 - *	
11	Supporting ring	1	B10038-T	B10133-T		B10150-T	B10227-T	B10320-T	
12	Space ring	1	B10037 - **	B10120 - **		B10223 - **		B10319 - **	
13	Fluid port ring nut	1	B10039 - **	B10122 - **		B10217 - **		B10321 - **	
14	Bleed screw	1	-			B10128 - **		B10316A - **	
15	Seal ring	1	-			B10129 - R		0010T14-1/4 - *	
16	Fluid port body std. version	1	B10031 - *** - **		B10115 - *** - **		B10144 - *** - **		B10311 - *** - **
	Fluid port body "P" version		B10031P - *** - **		B10115P - *** - **		B10144P - *** - **		B10311P - *** - **
17	Poppet	1	B10028 - **	B10111 - **		B10221 - **		B10310 - **	
18	Spring	1	B10029 - **	B10112 - **		B10149 - **		B10322 - **	
19	Brake bushing	1	-			B10113 - **		B10226 - **	
20	Selflocking nut	1	B10033 - **	B10116 - **		B10211 - **		B10315 - **	
21	Adapter	1	See chapter 3.1.9.5 ADAPTER						
Standard gas valve ass. (parts 3 ÷ 7)			V 2002 - ** / *	V 2021 - ** / *	V 2022 - ** / *		V 2042 - ** / *	V 2062 - ** / *	
Standard fluid port ass. (parts 9 ÷ 20)***			V 2004 - *** - ** / *	V 2023 - *** - ** / *	V 2024 - *** - ** / *	V 2025 - *** - ** / *	V 2044 - *** - ** / *	V 2064 - *** - ** / *	
Gasket sets			1	B2010* { 0010R2050* B10341-P B10342-P 0010R4112* B10038-T	B2030* { 0010R2050* B10341-P B10342-P 0010R4150* B10133-T B10129-R 0010R2093*	B2031* { 0010R2050* B10341-P B10342-P 0010R0159* B10150-T B10129-R 0010R3150*	B2050* { 0010R2050* B10341-P B10342-P 0010R6212* B10227-T B10129-R 0010R3150*	B2080* { 0010R2050* B10341-P B10342-P 0010R0181* B10320-T 0010T14-1/4* 0010R3218*	

* Gasket material

** Component material

*** See chapter 3.2.8 table 6 - 7

**** For "ASP" version valve order code become V xxxxP - thread version

3.1gb

3.1.11 COMMISSIONING AND MAINTENANCE

Delivery conditions

Bladder accumulators are delivered pre-charged with nitrogen at a pressure of 30 bar or at value of pressure required at time of order. The pre-charge value is also on the nameplate of the accumulator.

Depending on the size and quantity ordered, the bladder accumulators are shipped in boxes, in cartons, on pallets or wooden boxes on request. Unless otherwise required, certificates and documentation are provided together with the accumulators.

Handling

The original packaging is suitable for handling and storage. Where necessary, you should use suitable lifting equipment to support the weight of the accumulators.

However protect from impact the packaging and handle it with care.

Storage

During storage in the warehouse, leave the product in its original packaging, keeping it away from heat sources and naked flames. The storage temperature should be between +10 and +40°C.

In addition to six months of storage, the precharge pressure must be to two bar and make sure that inside there is lubrication fluid compatible with bladder polymer.

After six years of storage, it is essential to proceed with the replacement of all elastomeric parts before the commissioning.

Marking on the nameplate of the accumulator

With reference to the PED 97/23/EC classification, Article 3, Paragraph 3 and / or risk categories I or II depending to the volume and maximum working pressure, the accumulator indicates the following data:

- Logo, name and country of the manufacturer
- Month/year of production
- Product code
- Serial number
- Maximum PS pressure and PT test pressure in bar
- Min. and max. TS working temperature in Celsius
- Volume V in litres
- Group of fluids allowed (II)
- CE marking (for volumes exceeding 1 litre) with the identification number of the notified body
- Pre-charge pressure in bar

It is strictly forbidden to:

- weld, rivet or screw any item of the accumulator
- engrave or permanently stamp the surfaces of the accumulator shell and / or carry out other operations that could affect or change the mechanical properties of the accumulator
- use the accumulator as a structural element: it should not be subjected to stresses or loads
- change the data of the nameplate and / or accumulator without the permission of the manufacturer
- use a (dangerous) fluid of Group 1 with equipment designed and manufactured for fluids of Group 2.

Installation

Before installation, you must perform a visual check to verify that the accumulator has not suffered any damage during shipping / handling. Verify that the requested type matches with what stamped on the nameplate.

We recommend using the accumulator with a suitable security valve (see Chapter 8) or a security block type BS (see Chapter 9). This device provides user and equipment protection against possible damage caused by pressure surges and also makes the maintenance of the accumulator easier, facilitating the interception and the discharge.

Provide for a space of 200 mm above the gas pre-charge valve to allow access to and control of the pre-charge equipment (see Chap.11.1).

The accumulators type AS may be installed in any position from horizontal to vertical (preferably with the pre-charge valve at the top), and the nameplate must be visible.

Proceed to the assembly so that no abnormal force affects the pipes connected directly or indirectly to the accumulator, so we recommend the use of supporting components and also fastening (please see Chapter 7) to avoid the transmission of vibrations.

If are not used EPE safety blocks, make sure that the accumulator is connected to the hydraulic circuit by suitable connection devices.

Make sure the fluid is compatible with the elastomer of the bladder.

Check that the max. allowed accumulator pressure is equal to or greater than that of the hydraulic circuit and that the temperature during operation is maintained within the range expected.

Make sure the fluid does not contain contaminants and/or abrasive.

Pre-charge of nitrogen

Normally, the bladder accumulators are delivered pre-charged with pressurized gas. The pre-charge of gas can be controlled and / or adjusted before or after installation of the accumulator in the hydraulic circuit.

For the pre-charge, use only industrial dry nitrogen with a purity of min. 99%. It is important to use the nitrogen from a bottle equipped with a pressure reducing valve (see Chap.11.3). Use the EPE pre-charge and charging set type PC to check the charging pressure requires, and adjust if necessary. If the pre-charge pressure is lower than required, connect the charging hose on one side and the other side connect it to the nitrogen bottle or to the pressure reducer. Slowly fill the nitrogen in the accumulator until reaching a pressure slightly higher than that set value (+ 10 ÷ 15%). Close the bottle and remove the charging hose pipe from the pre-loading set; wait until the gas temperature has stabilized (2 hours) and calibrate the pressure, discharging the excess gas.

Make sure that the gas valve is not subject to losses and, if necessary, use soap and water.

Tighten the protective caps manually.

Hydraulic pressurization

- Check that the pre-charge pressure is adequate for the application.
 - Ensure that the hydraulic pressure never exceeds the max allowed pressure (PS) shown on the accumulator shell.
- To avoid this risk, use a safety item (see Chap. 9).

Maintenance

- Periodically check the pre-charge pressure of the gas: after the commissioning, check after 2-3 weeks of operation and if there were no leaks, repeat the operation after 3 months; if the pressure at the same temperature was stable, repeat the test yearly. For heavy-duty applications, check the pre-charge every 6 months.
- Periodically (yearly) carry out a visual inspection of the accumulator in order to detect any early signs of deterioration such as corrosion, deformation, etc.
- Comply with the requirements of the regulations concerning the verification of the functionality of the equipment according to the country of installation of the accumulator.

Repair

If for failure, scheduled check or retest it is necessary to remove the accumulator from the system, prior to removal, isolate the accumulator from the installation and discharge pressure of the liquid.

All bladder EPE accumulators of the AS and ASP series may be repaired. It may consist in replacing the bladder, the seals, the pre-charge valve and/or the parts of the gas and fluid valve.

For reasons of functionality and security, it is recommended to use only original spare parts.

Disassembly

- Fasten the accumulator firmly in a vice or on a bench in a horizontal position, taking care not to damage the outer surface.



3.1k

- Undo slotted round nut for hook wrench by using the hook wrench.



3.1h

- If you have not already carried out, unscrew the cap nut first and then the valve cap of the gas valve.



3.1i

- Remove the slotted nut and the retaining ring.



3.1j

- Allow gas escapes from the bladder with the help of the check valve until a pressure of 0 is displayed. Check if the bladder is now de-pressurizing an open valve.



3.1m

- Push enough oil valve into the housing until the sealing ring and the washer can be removed.



3.1l

- Remove gas valve, unscrew the nut on the gas valve and remove the nameplate.



3.1n

- Remove the sealing ring and the washer.



3.1o

- Remove the retaining ring, take it out, by carefully pushing the ring together.



3.1p

- Remove the oil valve from the shell.



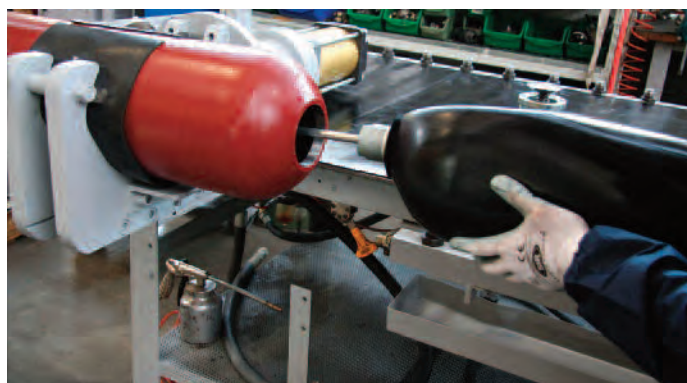
3.1q

- Fold bladder somewhat and withdraw by turning it slightly.

Refitting

Tightening torques in Nm				
	0.2 l	0.7-1.5 l	3 - 5 l	10-55 l
Fluid port ring nut	60 +10	100 +20	200 +50	450 +50
Bleed screw	3 +1	5 +1	5 +1	30 +10
Gas valve locknut	50 +10	80 +20	100 +20	150 +30
Filling valve V - VX - V2	-	30 +5	30 +5	30 +5
Valve insert V4	-	0.3 +0.2	0.3 +0.2	0.3 +0.2

- Cleaning and testing: clean all metallic parts on accumulator using an organic degreaser - visual inspection of oil valve parts (valve poppet, spring, nut, break bushing)
 - check valve for sluggishness
 - Clean bladder, i.e. using isopropanol. Visual inspection of bladder for faults - inner inspection of shell for signs of corrosion. In event of coated shell, check the condition of the coating.
- Replace the parts deemed to be bad; the o-rings must always be replaced (see spare parts Section 3.1.10).



3.1s

- Drain air from bladder by pressing together.



3.1t

- Carefully moisten the inside of the bladder and the shell with the same medium operation. That will be used during operation.



3.1u

- Reinstall according to this sequence: o-ring, support ring and space ring.



3.1v

- Tighten the hexagon nut SW1 on the gas valve.



3.1z

- Screw the slotted nut and centre the parts on the oil valve by using a plastic hammer.



3.1w

- Mount the filling valve.

Pre-charge



3.1zz

- Bleed screw with sealing ring.



3.1x

- Screw the pre-charge PC equipment on the gas valve.
- Connect the equipment to the cylinder of nitrogen or to the pressure reducer with the inflation tube.
- Slowly enter the nitrogen in the accumulator until reaching a pressure slightly higher than the set value (+ 10 ÷ 15%).
- Close the cylinder and remove the connecting pipe from the equipment.
- Wait until the gas temperature has stabilized (2 hours).
- Calibrate the pressure discharging the excess gas.

- Mount the bleed screw with its sealing ring.



3.1y

Make sure that the gas valve is not subject to losses and, if necessary, use soap and water.
Tighten the protective caps manually.

Demolition and recycling of the accumulator

Before accumulator demolition or recycling, you should always discharge completely the pre-charge pressure and remove the gas valve.
If needed, proceed decontaminating in relation to the fluid used prior to demolition.

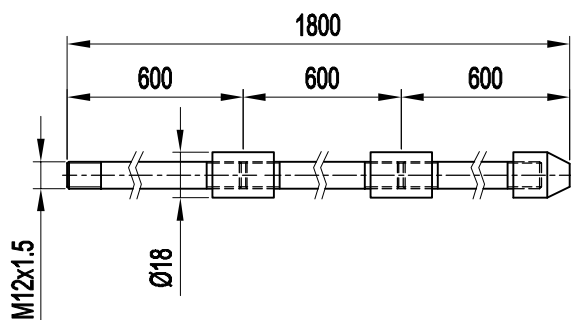
3.1.12 REPAIR TOOLS

3.1.12.1 BLADDER PULL ROD

The pull rod screwed to the gas valve of the bladder for easy assembly into shell during reassembly. Pull rod is complete with fitting for EPE gas valve and 3 extension segments to accommodate all size of accumulators.

Code for complete kit: B2505

Dimension



3.1aa

3.1.12.2 SPANNER WRENCH

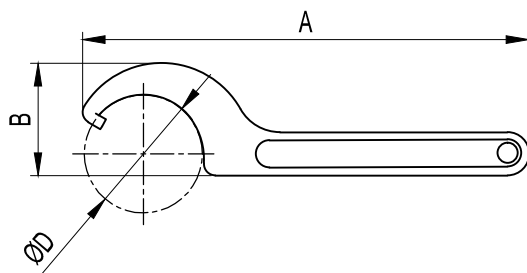
Fits all standard size bladder accumulator. It is used to remove or install lock nut on fluid port assembly.

0,7÷1,5 lt code 2506/58

3÷5 lt code 2506/68

10÷55 lt code 2506/105

Dimension



CODE	A	B	ØD	For Accumulator
B2506/58	241	45	58	0.7 ÷ 1.5
B2506/68	241	43	68	3 ÷ 5
B2506/105	336	82	105	10 ÷ 55

3.1ab

3.1.12.3 LIFTING HOOK

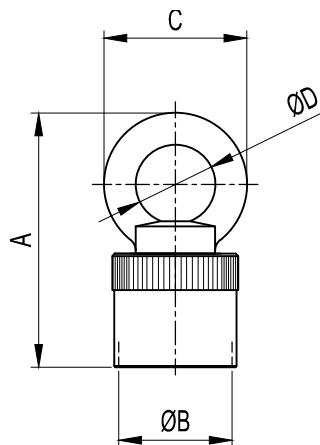
To be used for the safe lifting of mounted accumulators:

For accumulators 0,7÷5 lt (M22x1,5) code B2507/2

For accumulators 10÷55 lt (M50x1,5) code B2507/5

For accumulators V4 (7/8" UNF) code B2507/7

Dimension



CODE	A	ØB	C	ØD	For Accumulator
B2507/2	100	M22x1.5	63	35	0.7 ÷ 1.5
B2507/5	112	M50x1.5	63	35	3 ÷ 5
B2507/7	100	7/8" UNF	63	35	10 ÷ 55

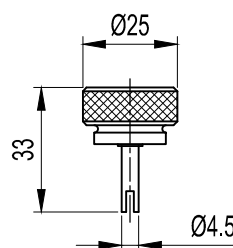
3.1ac

3.1.12.4 CORE TOOL

The core tool is used to remove and reinstall the valve core type V4.

Code B2508

Dimension



3.1ad

Reproduction is forbidden.

In the spirit of continuous improvement, our products may be changed.

3.2.1 TECHNICAL DATA

MAX OPERATING PRESSURE (PS): 360 bar

PRESSURE TEST (PT): 1.43 x PS

NOMINAL CAPACITIES:

ASL: 0.2 - 0.7 - 1 - 1.5 - 3 - 5 - 10 - 15 - 20 - 25 - 35 - 55 litres

AST: 1 - 1.5 - 3 - 5 - 10 - 15 - 20 - 25 - 35 - 55 litres

WORKING TEMPERATURE: -40 ÷ +150 °C

FLUID VISCOSITY RANGE: 10 ÷ 400 cSt

RECOMMENDED VISCOSITY: 36 cSt

FLUID CONTAMINATION DEGREE:

class 21/19/16 according to ISO 4406/99

BODY MATERIAL:

- carbon steel shell painted with rust inhibitor RAL 8012
- nickel coating 25 - 40 µ
- stainless steel AISI 316L
- internal and external coating with RILSAN th. 0.6 mm

VALVES MATERIAL:

- phosphated or galvanized carbon steel in compliance with Directive 2002/95/EC (RoHS) to resist to corrosion
- stainless steel AISI 316L
- nickel coating 25-40 µ

BLADDER MATERIAL:

- P = Nitrile rubber (NBR)
- F = Low temp. nitrile rubber
- H = Nitril for hydrocarbons
- K = Hydrogenated nitrile (HNBR)
- B = Butyl (IIR)
- E = Ethylene-propylene (EPDM)
- N = Chloroprene (Neoprene)
- Y = Epichlorohydrin (ECO)
- V = Fluorocarbon (FPM)

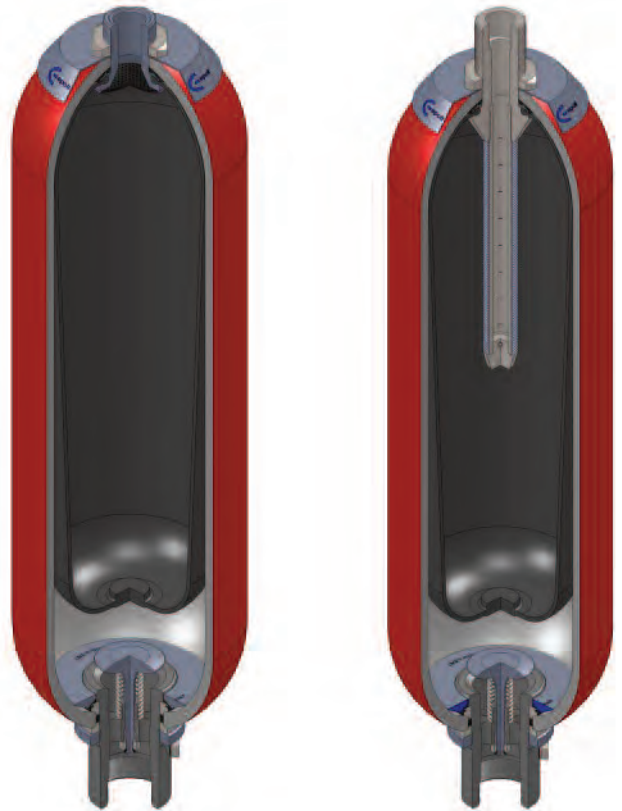
See Table 3.2c and/or Chapter 1.5

GAS VALVE CONNECTION: see 3.2db - 3.2dd

FLUID PORT CONNECTION: see 3.2de - 3.2dg - 3.2eb - 3.2ec
3.2fb - 3.2fd

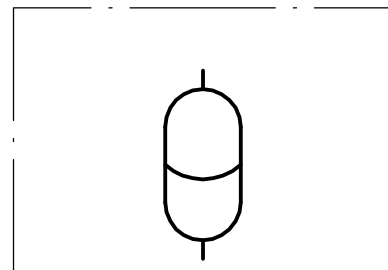
FLOW RATE: see Table 3.2db - 3.2dd

WEIGHT: see Table 3.2db - 3.2dd



3.2a

3.2.2 HYDRAULIC SYMBOL



3.2b

3.2.3 “ASL and AST” BLADDER ADVANTAGES

- dirt tolerant
- light weight
- compact
- simple construction
- quick response
- works well on water, low lubricity fluids
- quick, easy installation
- low cost

3.2.4 DESCRIPTION

Bladder accumulators' type ASL and AST consist of a seamless cylindrical pressure vessel made of high-tensile steel.

The accumulators are subdivided into a gas and fluid side by an elastic bladder mounted in the interior of the vessel.

In the ASL type, the liquid is also inside the bladder.

The transfer accumulator AST type is designed especially for connecting to nitrogen cylinders. A diffuser rod prevents damage to the bladder when the accumulator works.

Nitrogen cylinders used as back-ups increase the gas volume in the accumulator. This means that smaller accumulators can be used for the same gas volume and costs can be reduced.

When the fluid is pressed into the accumulator, the gas in the bladder is compressed and hence the pressure increased. The gas volume reduces and on the fluid side, the fluid can flow into the accumulator. As soon as the pressure on the fluid side falls below the gas pressure, the accumulator is emptied.

Oil valve is provided in the oil port of the bladder-type accumulator and closes when the pressure on the gas side is higher than the one on the fluid side. This prevents draining of the bladder into the oil channel and thus the bladder from being destroyed.

When the minimum operating pressure is reached, a small oil volume is to be maintained between the bladder and the fluid volume (approx. 10% of the nominal capacity of the hydraulic accumulator), in order that the bladder does not hit the valve during every expansion process.

The gas valve body of ASL type accumulator is complete with anti-extrusion in addition to the rubber washer and locknut.

The gas valve body of AST type accumulator is complete with diffuser rod in addition to the rubber washer and locknut.

These parts can be replaced separately.

The nameplate shows the technical data and features of the hydraulic accumulator.

3.2.5 EUROPE MARKET

All hydraulic accumulators are pressure vessels and are subject to the national regulations and directives valid at the place of installation.

Bladder accumulator type ASL and AST, up to and including 1 litre, must not be CE marked.

For bladder accumulator type ASL and AST, greater than 1 litre, every shipping batch is complete of a conformity declaration and instruction of use and maintenance and/or all documents requested.

All vessel categories (see Table 3.2db, 3.2dd) must be protected by means of a pressure relief valve in accordance with Directive 97/23/EC.

3.2.6 ACCESSORIES

For additional cylinders, see Section 6

For support equipment, see Cap. 7

For gas side's safety equipment, see Cap. 8

For fluid side's safety equipment, see Cap. 9

For pre-loading and charging set, see Cap. 11

For other components, see Cap. 12

3.2.7 BLADDER-TEMPERATURE-LIQUID COMPATIBILITY

When selecting the accumulator variant, pay attention to the following non-binding notes with regard to hydraulic fluid, bladder material and the permissible temperature range. (see Section 1.5)

Code letter	Polymer	ISO	Temperature range (°C)	Some of the liquids compatible with the polymer
P	Standard nitrile (Perburan)	NBR	-20 ÷ +80	Aliphatic hydrocarbons (propane, butane, gasoline, oils, mineral greases, diesel fuel, fuel oil, kerosene), mineral greases and oils, HFA - HFB - HFC fluids, many dilute acids, alkalis, saline solutions, water, water glycol.
F	Low temperature nitrile	NBR	-40 ÷ +70	The same as with standard nitrile + a number of different types of Freon. (This contains less acrylonitrile than the standard and is therefore more suitable for low temperatures, but its chemical resistance is slightly lower).
H	Nitrile for hydrocarbons	NBR	-10 ÷ +90	Regular and premium grade slightly aromatic gasoline (and all the liquids for standard nitrile).
K	Hydrogenated nitrile	HNBR	-30 ÷ +130	The same as with standard nitrile but with excellent performance at high and low temperatures.
B	Butyl	IIR	-30 ÷ +100	Hot water up to 100°C, glycol-based brake fluids, many acids and bases, salt solutions, polar solvents such as alcohols, ketones and esters, polyglycol-based hydraulic fluids (HFC fluids) and bases of esters of phosphoric acid (HFD-R fluids), silicone oils and greases, Skydol 500 and 7000, resistance to ozone, aging and weathering.
E	Ethylene-Propylene	EPDM	-30 ÷ +100	Hot water up to 100°C, glycol-based brake fluids, many organic and inorganic acids, detergents, solutions of sodium and potassium, phosphate ester-based hydraulic fluids, (HFD-R), silicone oils and greases, many polar solvents (alcohol, ketones, esters), Skydol 500 and 7000, resistance to ozone, aging and weathering.
N	Chloroprene (Neoprene)	CR	-30 ÷ +100	Mineral oils of paraffin, silicone oils and greases, water and aqueous solutions, refrigerants (ammonia, carbon dioxide, Freon), naphthenic mineral oils, low molecular aliphatic hydrocarbons (propane, butane, fuel), brake fluids based on glycol, better resistance to ozone, weathering and aging compared to NBR rubber.
Y	Epichloridrin	ECO	-30 ÷ +110	Mineral oils and greases, aliphatic hydrocarbons (propane, butane and gasoline), silicone oils and greases, water at room temperature, resistance to ozone, aging and weathering.
V	Fluorocarbon	FPM	-10 ÷ +150	Mineral oils and greases, non-flammable fluids of HFD group, silicone oils and greases, animal and vegetable oils and greases, aliphatic hydrocarbons (gasoline, butane, propane, natural gas), aromatics hydrocarbons (benzene, toluene), chlorinated hydrocarbons (Tetrachloroethylene, carbon tetrachloride), fuel (regular, super and containing methanol), excellent resistance to ozone, weathering and aging.

For other hydraulic fluid and/or temperatures, please consult us.

3.2c

3.2.8 ORDER CODE

1	2	3	4	5	6	7-8	9	10	11	12	13	14	15		
AST	25	P	360	C	R	G8	G6	-	8	-	C	0	C	1	R250

1 Series	Bladder accumulator liquid separator = ASL Bladder accumulator transfer = AST
2 Nominal capacity	0.2 lt = 0.2 0.7 lt = 0.7 1 lt = 1 1.5 lt = 1.5 3 lt = 3 5 lt = 5 10 lt = 10 15 lt = 15 20 lt = 20 25 lt = 25 35 lt = 35 55 lt = 55
3 Bladder material	Nitrile rubber (NBR) = P Nitrile for low temp. = F Nitril for hydrocarbons = H Hydrogenated nitrile (HNBR) = K Butyl (IIR) = B Ethylene-propylene (EPDM) = E Chloroprene (Neoprene) = N Epichlorohydrin (ECO) = Y Fluorocarbon (FPM) = V
4 Max working pressure (PS)	See the table on front page
5 Body material	Carbon steel = C Nickel coated carbon steel 25 μ = N Nickel coated carbon steel 40 μ = M Stainless steel = X Rilsan coating = V
6 Fluid port connection	See the table on front page
7-8 Dimension of the connection fluid or 7+8 table	See the table on front page
9 Connection gas side	Capacity 0.2 l = G1 Capacity 0.7 ÷ 5 l = G2 Capacity 10 ÷ 55 l = G6
10 Test and certification	Factory testing = 0 TR (Russia) = 1 Australian Standard = 2 ML (China) = 3 RINA = 4 PED 97/23/EC (for capacities greater than 1 l) = 8 ATEX 94/9EC = 9 DNV = 10 RTN Passport (Ukraine) = 11 Algeria passport = 12 Standard regulation (NR13) (Brazil) = 13 Tunisia passport = 14
11 Fluid valve material	Carbon steel = C Nickel coated carbon steel 25 μ = N Nickel coated carbon steel 40 μ = M Stainless steel = X
12 Variants of fluid side	Standard = 0 Adapter in stainless steel (R) = 1 Button and spring in stainless steel = 2 Other numbers/variants to be requested EPE
13 Gas valve material	Carbon steel = C Nickel coated carbon steel 25 μ = N Nickel coated carbon steel 40 μ = M Stainless steel = X
14 Variants of gas side	Standard = 0 Only cap in stainless steel = 1 Brass nameplate = 2 Other numbers/variants to be requested EPE
15 Other variants	See the table on front page

Special variants upon request

4 Max working pressure (PS)		
Capacity litres	Carbon steel	Stainless steel
AST 0,7 ÷ 55	360 (210 only for the version with connection L or other pressure related to connections B or U)	80 - 150 - 210 - 360
ASL 0,2 ÷ 55		

6 Fluid port connection		
For ASx 0.7÷55 BSP ISO 228 with chamfer for OR (std)	=	A
For ASx 0.2 BSP ISO 228 (std)	=	G
For ASx 3÷55 Metric	=	M
For ASx 0.7÷55 NPT-F	=	P
For ASx 3÷55 internal thread SAE	=	S
For ASx 3÷55 adapter for flange SAE 3000 Psi	=	L
For ASx 3÷55 adapter for flange SAE 6000 Psi	=	H
For ASx 0.7÷55 flange ANSI	=	B
For ASx 0.7÷55 flange UNI	=	U
For ASx 0.7÷55 square flange	=	Q
For ASx 0.7÷55 adapter *	=	R

* assembled on the fluid valve connection type A

7 Dimension of the fluid connection		
For the type of connection:		
A (0.7÷1.5 l) 3/4"	=	5
(3÷5 l) 1" 1/4	=	7
(10÷55 l) 2"	=	9
G (0.2 l) 1/2"	=	4
M (3÷5 l) 40x1.5	=	40/1.5
(10÷55 l) 50x1.5	=	50/1.5
P (0.7÷1.5 l) 3/4"	=	5
(3÷5 l) 1" 1/4	=	7
(10÷55 l) 2"	=	9
S (0.7÷1.5 l) 1" 1/16 12UN	=	1 1/16-12
(3÷5 l) 1" 5/8 12UN	=	1 5/8-12
(10÷55 l) 1" 7/8 12UN	=	1 7/8-12
L (3÷5 l) 1" 1/4 SAE3000	=	7
(10÷55 l) 1" 1/2 SAE 3000	=	8
2" SAE 3000	=	9
H (3÷5 l) 1" 1/4 SAE6000	=	7
(10÷55 l) 1" 1/2 SAE 6000	=	8
2" SAE 6000	=	9
B (0.7÷55 l)	DIMENSION/RATING	
Former. 1" ANSI 1500 = 1/1500 (Pmax = 250 bar)		
U (0.7÷55 l)	DN/PN	
Former. DN50 PN100 = 50/100 (Pmax = 100 bar)		8
Q (3÷5 l) 1" 1/4	=	7
(10÷55 l) 2"	=	9
R (0.7÷55 l) Blind	=	0
R (0.7÷55 l) internal thread	=	G*
BSP ISO 228	=	P*
NPT-F	=	N*
BSPT	=	N*
SAE	=	S*
Metric	=	M*

15 Other variants	
Burst disc set at xxx bar, laterally on AST (see Section 8.2)	= Rxxx
Needle Valve of 1/4" BSP, laterally on AST	= EG2
Flushing with degree of contamination ≤ x	= Fx
75-80 μ thick polyurethane paint with colour to be specified	= Wxxx
Off-shore paint with colour to be specified	= Zxxx
NORSOK System 1 paint with colour to be specified	= K1
NORSOK System 7 paint with colour to be specified	= K7
other variants upon request	

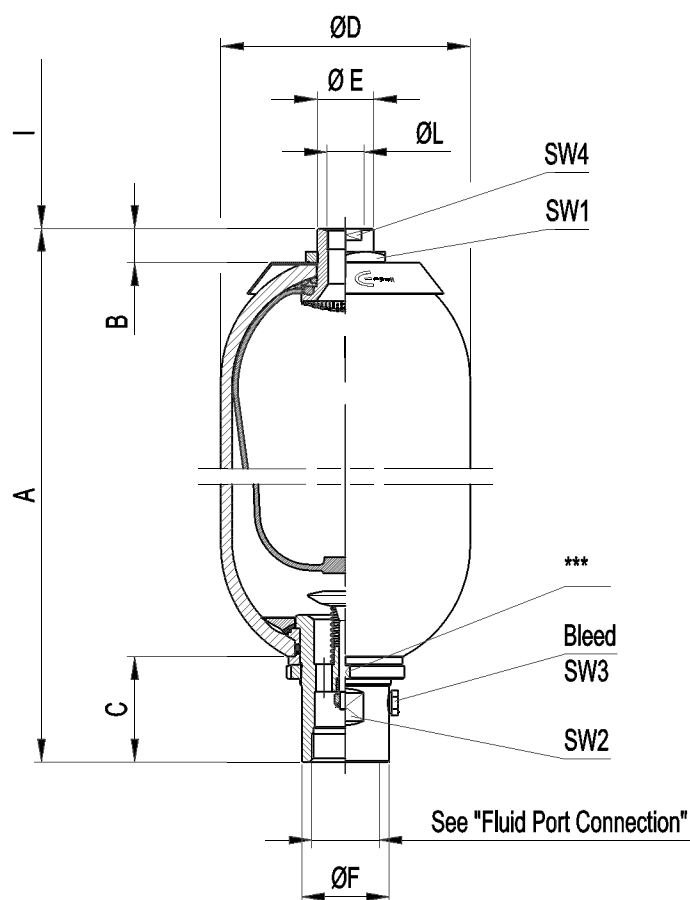
Dimension					
1/8"	=	1	3/4"	=	5
1/4"	=	2	1"	=	6
3/8"	=	3	1" 1/4"	=	7
1/2"	=	4	1" 1/2"	=	8

Dimension in inch - No. of pitch for inch
Diameter/pitch

*Variant in table 8

Special variants upon request

3.2.9 ASL VERSION DIMENSIONS



3.2da

Acc. type ASL in carbon steel	Nominal gas volume litres	Effective gas volume litres	Working pressure bar	Ped category liquids of group 2	Max. diff. pressure P2-P1 bar	Flow rate l/min	Max. comp. ratio P0/P2	A mm	B mm	C mm	Ø D mm	Ø E mm	Ø L mm	Ø F mm	I mm	SW 1 mm	SW 2 mm	SW 3 mm	SW 4 mm	Bleed	Acc. dry weight kg
ASL 0,2	0,2	0,2	360	Art.3 (3)	100	160	1:4	247 ± 2	18	40	53	5/8" UNF	1/8" BSP	26	140	24	23	4*	18	M5	1,7
ASL 0,7	0,7	0,65	360	Art.3 (3)	100	300	1:4	253 ± 1,5	20	52	90	M22x1,5	1/4" BSP	36	140	32	32	4*	18	M5	4,2
ASL 1	1	1	360	Art.3 (3)	100	300	1:4	268 ± 5	20	52	114	M22x1,5	1/4" BSP	36	140	32	32	4*	18	M5	5,2
ASL 1,5	1,5	1,5	360	II	100	300	1:4	328 ± 5	20	52	114	M22x1,5	1/4" BSP	36	140	32	32	4*	18	M5	6,3
ASL 3	3	2,95	360	III	100	600	1:4	526 ± 8	20	65	114	M22x1,5	1/4" BSP	53	140	32	50	4*	18	M5	11
ASL 5	5	5	360	III	100	600	1:4	434 ± 10	23	65	168	M22x1,5	1/4" BSP	53	140	32	50	4*	18	M5	15
ASL 10	10	9,1	360	IV	100	1000	1:4	535 ± 10	28	101	220	M50x1,5	1" BSP	77	140	70	70	19**	41	1/4" BSP	33
ASL 15	15	14,5	360	IV	100	1000	1:4	685 ± 10	28	101	220	M50x1,5	1" BSP	77	140	70	70	19**	41	1/4" BSP	43
ASL 20	20	18,2	360	IV	100	1000	1:4	845 ± 10	28	101	220	M50x1,5	1" BSP	77	140	70	70	19**	41	1/4" BSP	48
ASL 25	25	23,5	360	IV	100	1000	1:4	1010 ± 15	28	101	220	M50x1,5	1" BSP	77	140	70	70	19**	41	1/4" BSP	59
ASL 35	35	33,5	360	IV	100	1000	1:4	1360 ± 15	28	101	220	M50x1,5	1" BSP	77	140	70	70	19**	41	1/4" BSP	78
ASL 55	55	50	360	IV	100	1000	1:4	1870 ± 15	28	101	220	M50x1,5	1" BSP	77	140	70	70	19**	41	1/4" BSP	108

* Allen wrench

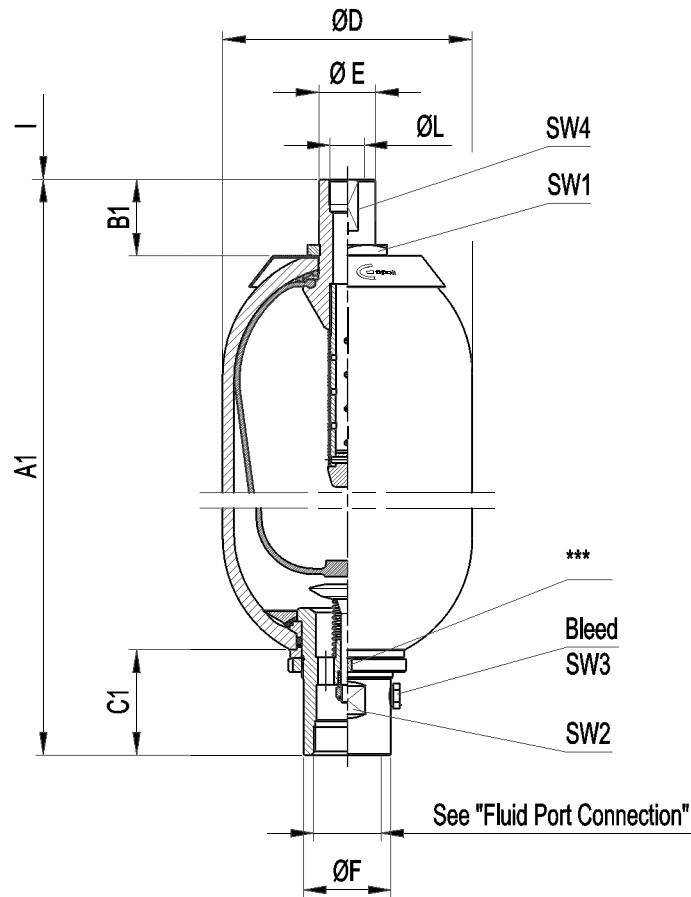
** Ex. wrench

*** see chapter 3.2.12.2 table 3.2ab

3.2db

* The maximum differential pressure is the maximum allowable difference between the maximum pressure and the minimum working pressure (P2-P1) to have an infinite life cycle of the accumulator (greater than 2,000,000 cycles).

** Flow rate measured using mineral oil with viscosity of 36 cSt at 50°C and ΔP = 5 bar

3.2.9 AST VERSION DIMENSIONS


3.2dc

Acc. type AST in carbon steel	Nominal gas volume litres	Effective gas volume litres	Working pressure bar	Ped category liquids of group 2	Max.diff. pressure P2-P1 bar	Flow rate l/min	Max.comp. ratio P0/P2	A 1 mm	B 1 mm	C 1 mm	Ø D mm	Ø E mm	Ø L mm	Ø F mm	I mm	SW 1 mm	SW 2 mm	SW 3 mm	SW 4 mm	Bleed	Acc. dry weight kg
AST 0,2	-	-	-	-	-	-	-	-	-	-	-	-	-	-	-	-	-	-	-	-	-
AST 0,7	0,7	0,7	360	Art.3 (3)	100	300	1:4	269 ± 5	28	52	90	M22x1,5	1/4" BSP	36	140	32	32	4*	18	M5	3,7
AST 1	1	1	360	Art.3 (3)	100	300	1:4	276 ± 5	28	52	114	M22x1,5	1/4" BSP	36	140	32	32	4*	18	M5	5,2
AST 1,5	1,5	1,5	360	II	100	300	1:4	336 ± 5	28	52	114	M22x1,5	1/4" BSP	36	140	32	32	4*	18	M5	6,3
AST 3	3	2,95	360	III	100	600	1:4	534 ± 8	28	65	114	M22x1,5	1/4" BSP	53	140	32	50	4*	18	M5	11
AST 5	5	5	360	III	100	600	1:4	439 ± 10	28	65	168	M22x1,5	1/4" BSP	53	140	32	50	4*	18	M5	15
AST 10	10	9,1	360	IV	100	1000	1:4	573 ± 10	66	101	220	M50x1,5	1" BSP	77	140	70	70	19**	46	1/4" BSP	33
AST 15	15	14,5	360	IV	100	1000	1:4	723 ± 10	66	101	220	M50x1,5	1" BSP	77	140	70	70	19**	46	1/4" BSP	43
AST 20	20	18,2	360	IV	100	1000	1:4	883 ± 10	66	101	220	M50x1,5	1" BSP	77	140	70	70	19**	46	1/4" BSP	48
AST 25	25	23,5	360	IV	100	1000	1:4	1048 ± 15	66	101	220	M50x1,5	1" BSP	77	140	70	70	19**	46	1/4" BSP	59
AST 35	35	33,5	360	IV	100	1000	1:4	1398 ± 15	66	101	220	M50x1,5	1" BSP	77	140	70	70	19**	46	1/4" BSP	78
AST 55	55	50	360	IV	100	1000	1:4	1908 ± 15	66	101	220	M50x1,5	1" BSP	77	140	70	70	19**	46	1/4" BSP	108

* Allen wrench

** Ex. wrench

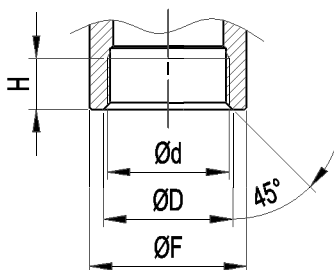
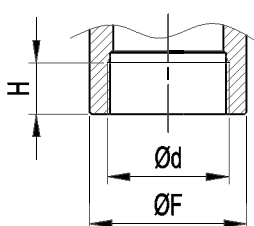
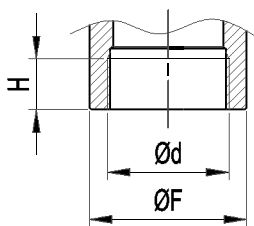
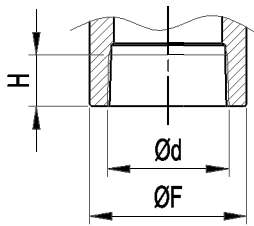
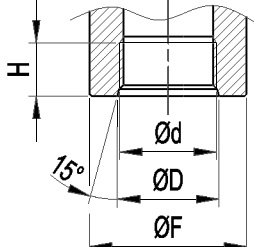
*** see chapter 3.2.12.2 table 3.2ab

3.2dd

* The maximum differential pressure is the maximum allowable difference between the maximum pressure and the minimum working pressure (P2-P1) to have an infinite life cycle of the accumulator (greater than 2,000,000 cycles).

** Flow rate measured using mineral oil with viscosity of 36 cSt at 50°C and ΔP = 5 bar

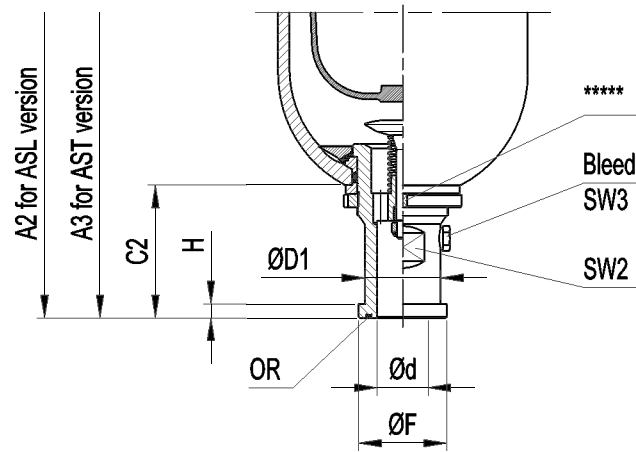
3.2.9.1 STANDARD THREAD CONNECTIONS

Dimensions	Connection Type	Accumulator type	Complete spare valve order code	Ød	ØD mm	ØF mm	H mm
	A BSP ISO 228 with chamfer for OR	ASL/AST 0,2	-	-	-	-	-
		ASL/AST 0,7	V 2023-A5-***/*	3/4" BSP	28,8	36	19
		ASL/AST 1	V 2024-A5-***/*				
		ASL/AST 1,5	V 2025-A7-***/*	1" 1/4 BSP	46	53	25
		ASL/AST 3	V 2044-A7-***/*				
		ASL/AST 5	V 2064-A9-***/*				
			G BSP ISO 228	ASL/AST 0,2	V 2004-G4-***/*	1/2" BSP	-
ASL/AST 0,7	-			-	-	-	-
ASL/AST 1	-			-	-	-	-
ASL/AST 1,5	-			-	-	-	-
ASL/AST 3	-			-	-	-	-
ASL/AST 5	-			-	-	-	-
ASL/AST 10 + 55	-			-	-	-	-
	M Metric	ASL/AST 0,2	-	-	-	-	-
		ASL/AST 0,7	-	-	-	-	-
		ASL/AST 1	-	-	-	-	-
		ASL/AST 1,5	-	-	-	-	-
		ASL/AST 3	V 2025-M40x1.5-***/*	M40x1,5	-	53	25
		ASL/AST 5	V 2044-M40/1.5-***/*	-	-	-	-
		ASL/AST 10 + 55	V 2064-M50/1.5-***/*	M50x1,5	-	77	28
	P NPT-F	ASL/AST 0,2	-	-	-	-	-
		ASL/AST 0,7	V 2023-P5-***/*	3/4" NPT-F	-	36	Thread plug gage
		ASL/AST 1	V 2024-P5-***/*				
		ASL/AST 1,5	V 2025-P7-***/*	1" 1/4 NPT-F	-	53	
		ASL/AST 3	V 2044-P7-***/*				
		ASL/AST 5	V 2064-A9-***/*				
		ASL/AST 10 + 55	V 2064-A9-***/*	2" NPT-F	-	77	
	S SAE thread	ASL/AST 0,2	-	-	-	-	
		ASL/AST 0,7	V 2023-S1/16-12-***/*	1" 1/16 12 UN	29,16	36	19
		ASL/AST 1	V 2024-S1/16-12-***/*				
		ASL/AST 1,5	V 2025-S1 5/8-12-***/*	1" 5/8 12 UN	43,5	53	23
		ASL/AST 3	V 2044-S1 5/8-12-***/*				
		ASL/AST 5	V 2064-S1 7/8-12-***/*				
		ASL/AST 10 + 55	V 2064-S1 7/8-12-***/*	1" 7/8 12 UN	49,84	77	26

* Gasket material

** Component material

3.1de

3.1.9.2 ADAPTER FOR FLANGE SAE 3000/6000 PSI (L/H)

3.1df

Acc. type ASL / AST in carbon steel	Dim.	A2 - ASL mm	A3 - AST mm	C2 mm	SW2 mm	SW3 mm	Bleed	Ød mm	SAE 3000 (L)				SAE6000 (H)				OR (Included)	Acc. dry weight kg
									Spare valve order code	ØD1 mm	ØF mm	H mm	Spare valve order code	ØD1 mm	ØF mm	H mm		
ASL / AST 0,2	-	-	-	-	-	-	-	-	-	-	-	-	-	-	-	-	-	-
ASL / AST 0,7	-	-	-	-	-	-	-	-	-	-	-	-	-	-	-	-	-	-
ASL / AST 1	-	-	-	-	-	-	-	-	-	-	-	-	-	-	-	-	-	-
ASL / AST 1,5	-	-	-	-	-	-	-	-	-	-	-	-	-	-	-	-	-	-
ASL / AST 3	1"	562± 8	570± 8	100	38	4***	M5	-	-	-	-	-	V 2025-H6-***	38	47,6	9,5	0010R4131-*	11
	1 1/4"	551 ± 8	559 ± 8	89				31	V 2025-L7-***	43	50,8	8	V 2025-H7-***	44	53,3	10,3	0010R4150-*	
ASL / AST 5	1"	469 ± 10	474 ± 10	100	38	4***	M5	-	-	-	-	-	V 2044-H6-***	38	47,6	9,5	0010R4131-*	15
	1 1/4"	458 ± 10	463 ± 10	89				31	V 2044-L7-***	43	50,8	8	V 2044-H7-***	44	53,3	10,3	0010R4150-*	
ASL / AST 10	1 1/2"	550 ± 10	588 ± 10	115	42	19****	1/4"	32	V 2064-L8-***	50	60,3	8	V 2064-H8-***	51	63,5	12,5	0010R4187-*	33
	2"							45	V 2064-L9-***	62	71,5	9,5	V 2064-H9-***	67	77,6	12,5	0010R4225-*	
ASL / AST 15	1 1/2"	700 ± 10	738 ± 10	115	42	19****	1/4"	32	V 2064-L8-***	50	60,3	8	V 2064-H8-***	51	63,5	12,5	0010R4187-*	43
	2"							45	V 2064-L9-***	62	71,5	9,5	V 2064-H9-***	67	77,6	12,5	0010R4225-*	
ASL / AST 20	1 1/2"	860 ± 10	898 ± 10	115	42	19****	1/4"	32	V 2064-L8-***	50	60,3	8	V 2064-H8-***	51	63,5	12,5	0010R4187-*	48
	2"							45	V 2064-L9-***	62	71,5	9,5	V 2064-H9-***	67	77,6	12,5	0010R4225-*	
ASL / AST 25	1 1/2"	1025 ± 15	1063 ± 15	115	42	19****	1/4"	32	V 2064-L8-***	50	60,3	8	V 2064-H8-***	51	63,5	12,5	0010R4187-*	59
	2"							45	V 2064-L9-***	62	71,5	9,5	V 2064-H9-***	67	77,6	12,5	0010R4225-*	
ASL / AST 35	1 1/2"	1375 ± 15	1413 ± 15	115	42	19****	1/4"	32	V 2064-L8-***	50	60,3	8	V 2064-H8-***	51	63,5	12,5	0010R4187-*	78
	2"							45	V 2064-L9-***	62	71,5	9,5	V 2064-H9-***	67	77,6	12,5	0010R4225-*	
ASL / AST 55	1 1/2"	1885 ± 15	1923 ± 15	115	42	19****	1/4"	32	V 2064-L8-***	50	60,3	8	V 2064-H8-***	51	63,5	12,5	0010R4187-*	108
	2"							45	V 2064-L9-***	62	71,5	9,5	V 2064-H9-***	67	77,6	12,5	0010R4225-*	

* Gasket material

** Component material

*** Allen wrench

**** Ex. Wrench

***** see chapter 3.2.12.2 table 3.1ab

3.1dg

3.2.9.3 FLANGE CONNECTION TYPE ANSI / UNI DIN (B/U)

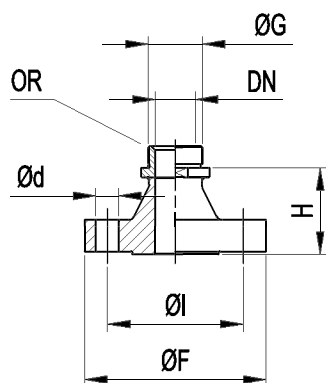


Fig. I

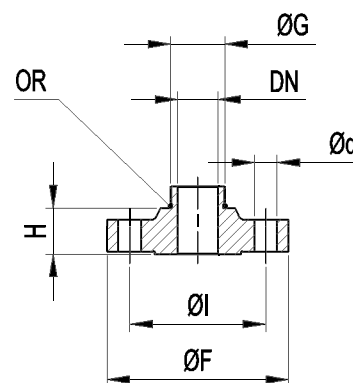
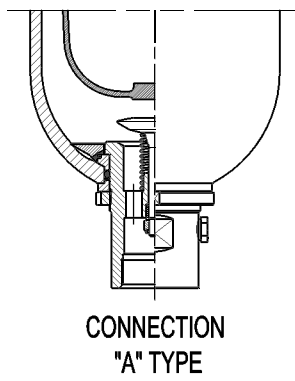


Fig. II

3.2ea

	Accumulator type	Spare flange order code	Ref. Directive		DN mm	PN bar	Fig.	Ø F mm	Ø I mm	Ø d mm	N° Holes	H mm	G BSP	OR (Included)
			UNI	DIN										
U (UNI-DIN)	ASL / AST 0,7 - 1 - 1,5	F 2205 - ** / *	2284	2635	20	40	II	105	75	14	4	23	3/4"	0010R2093-*
		F 2206 - ** / *	6086	2628				135	95	18	4	45		
	ASL / AST 3 - 5	F 2211 - ** / *	2284	2635	25	40	I	115	85	14	4	51	1 1/4"	0010R3150-*
		F 2212 - ** / *	6086	2628				150	105	22	4	76		
		F 2215 - ** / *	2284	2635	32	40	II	140	100	18	4	22		
		F 2216 - ** / *	6086	2628				165	120	22	4	55		
	ASL / AST 10 ÷ 55	F 2221 - ** / *	2282	2633	25	16	I	115	85	14	4	49	2"	0010R3218-*
		F 2222 - ** / *	2284	2635				115	85	14	4	51		
		F 2223 - ** / *	6086	2628				150	105	22	4	76		
		F 2227 - ** / *	2284	2635	40	40	I	150	110	18	4	56		
		F 2228 - ** / *	6086	2628				185	135	25	4	91		
		F 2231 - ** / *	2282	2633	50	16	II	165	125	18	4	23		
		F 2232 - ** / *	2285	2636				185	135	22	4	40		
		F 2233 - ** / *	6086	2628				200	150	25	8	61		

* Gasket material

** Flange material

Others size on request

3.2eb

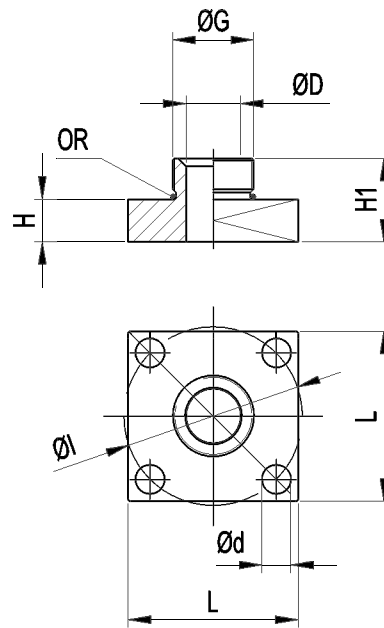
	Accumulator type	Spare flange order code	Ref. Directive	DN inch	PN lbs	Fig.	Ø F mm	Ø I mm	Ø d mm	N° Holes	H mm	G BSP	OR (Included)
F 2208 - ** / *	B16.5	130	88,9	22,5	4	59							
ASL / AST 3 - 5	F 2213 - ** / *	B16.5	1"	300	I	123,5	88,9	22,5	4	73	1 1/4"	0010R3150-*	
	F 2214 - ** / *	B16.5				149,5	101,6	25,4	4	90			
	F 2217 - ** / *	B16.5	1 1/4"	300	II	133,3	98,4	19	4	44			
	F 2218 - ** / *	B16.5				159	111,1	25,4	4	58			
ASL / AST 10 ÷ 55	F 2225 - ** / *	B16.5	1"	300	I	123,5	88,9	19	4	73	2"	0010R3218-*	
	F 2226 - ** / *	B16.5				149,5	101,6	25,4	4	90			
	F 2229 - ** / *	B16.5	1 1/2"	300	I	155,6	114,3	22,2	4	79			
	F 2230 - ** / *	B16.5				178	123,8	28,5	4	100			
	F 2235 - ** / *	B16.5	2"	400	II	165	127	19	8	55			
	F 2236 - ** / *	B16.5				216	165,1	25,4	8	83			

* Gasket material

** Flange material

Others size on request

3.2ec

3.2.9.4 SQUARE FLANGE CONNECTION


3.2fa

Accumulator type	Spare square flange order code	α G BSP	$\varnothing D$ mm	L mm	$\varnothing I$ mm	H mm	$\varnothing d$ mm	H1 mm	Weight Kg	OR (Included)
ASL / AST 3 - 5	F 2454 A7 - ** / *	1" 1/4 BSP	26	100	105	25	17.5	49	0,8	0010R3150 - *
ASL / AST 10 + 55	F 2455 A9 - ** / *	2" BSP	32						0,9	0010R3218 - *

* Gasket material

** Square flange material

Weigth indicated only for blind version

3.2fb

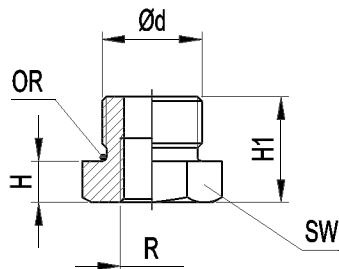
3.1.9.5 ADAPTER


Fig. I

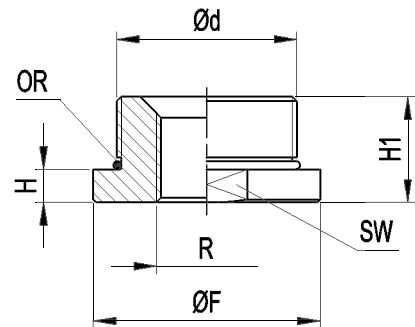


Fig. II

3.2fc

Accumulator type	Order code	$\varnothing d$ Acc. connection	R**** Out connections (0 = blind)	Fig.	SW mm	$\varnothing F$ mm	H mm	H1 mm	OR (Included)	Weight Kg
ASL / AST 0,7 - 1 - 1,5	R - A5*** - ** / *	3/4" BSP	1/8" + 3/8" BSP - NPT - BSPT	I	32	-	11	28	0010R2093 - *	0,14
			1/2" BSP - NPT - BSPT	I			28	45		0,27
ASL / AST 3 - 5	R - A7*** - ** / *	1" 1/4 BSP	1/8" + 1" BSP - NPT - BSPT	II	48	53	11	32	0010R3150 - *	0,41
ASL / AST 10 + 55	R - A9*** - ** / *	2" BSP	1/8" + 1" 1/2 BSP - NPT - BSPT	II	70	75	11	35	0010R3218 - *	0,86

* Gasket material

** Adapter material

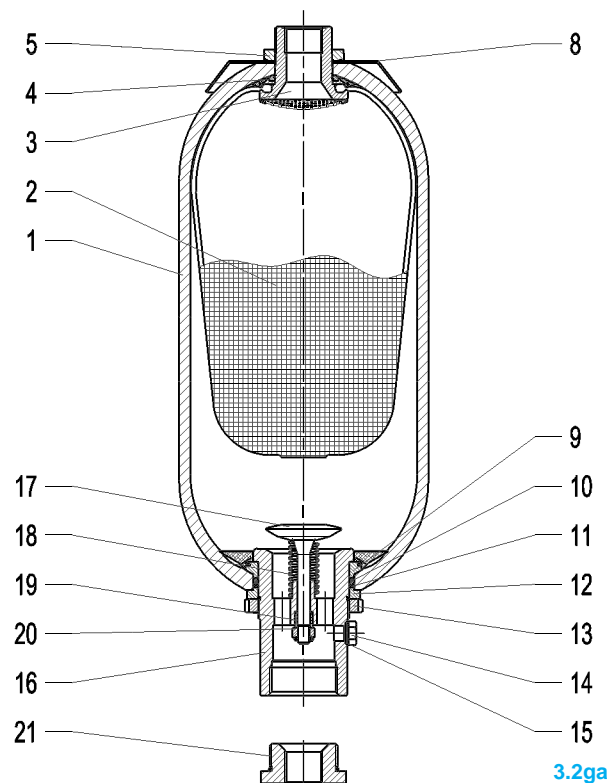
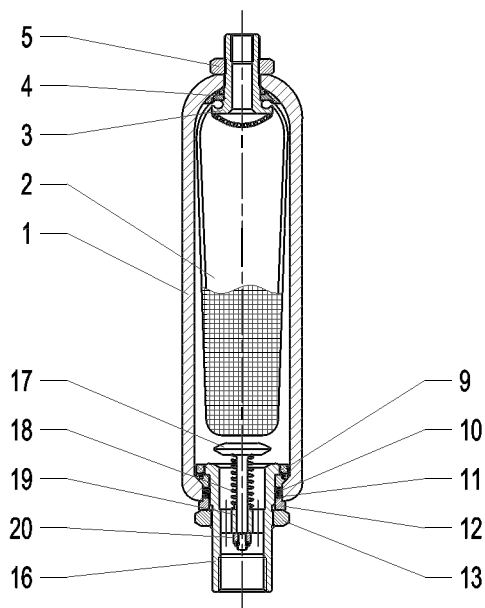
*** See chapter 3.2.8 table 7 - 8

Weigth indicated only for blind version

3.2fd

**** R Out connections type "S" and "M" thread on request

3.2.10. ASL VERSION SPARE PARTS CODE

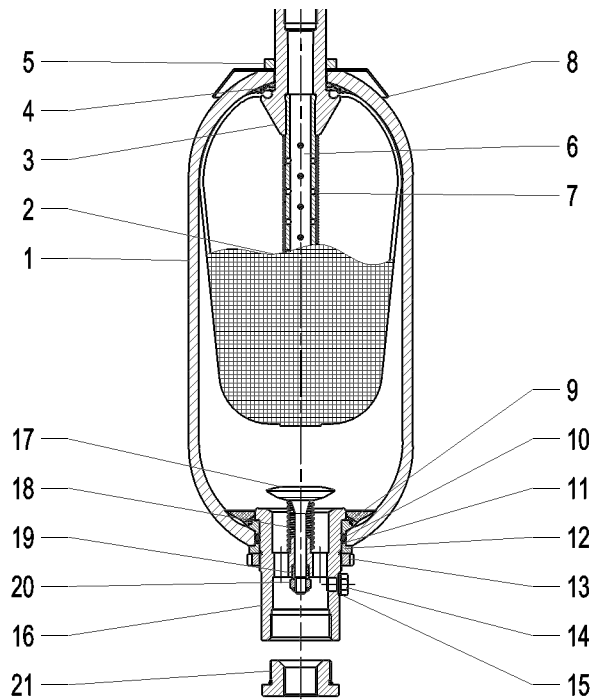


3.2ga

Item	Description	Q.ty	Type						
			ASL 0,2	ASL 0,7	ASL 1 - 1,5	ASL 3	ASL 5	ASL 10 + 55	
1	Accumulator shell	1	Not supplied as spare part						
2	Bladder	1	S0.2* - 0	S0.7* - 0	S1* - 0 / S1.5* - 0	S3* - 0	S5* - 0	S10 + 55* - 0	
3	Gas valve body	1	B10022A - **	B10132A - **			B10229A - **	B10431A - **	
4	Rubber-coated washer	1	B10024 - ** / *	B10104 - ** / *	B10106 - ** / *		B10205 - ** / *	B10334 - ** / *	
5	Gas valve looknut	1	B10023 - **	B10109 - **			B10302 - **		
6	-	1	-	-					
7	-	1	-	-					
8	Name plate	1	-	D10300A-A			D10300C-A	D10300E-A	
9	Retaining ring	1	B10035 - ** / *	B10123 - ** / *	B10127 - ** / *	B10146 - ** / *	B10222 - ** / *	B10317 - ** / *	
10	"O" ring	1	0010R4112 - *	0010R4150 - *		0010R0159 - *	0010R6212 - *	0010R0181 - *	
11	Supporting ring	1	B10038-T	B10133-T		B10150-T	B10227-T	B10320-T	
12	Space ring	1	B10037 - **	B10120 - **		B10223 - **		B10319 - **	
13	Fluid port ring nut	1	B10039 - **	B10122 - **		B10217 - **		B10321 - **	
14	Bleed screw	1	-	B10128 - **			B10316A - **		
15	Seal ring	1	-	B10129 - R			0010T14-1/4 - *		
16	Fluid port body std. version	1	B10031 - *** - **	B10115 - *** - **		B10144 - *** - **		B10311 - *** - **	
17	Poppet	1	B10028 - **	B10111 - **		B10221 - **		B10310 - **	
18	Spring	1	B10029 - **	B10112 - **		B10149 - **		B10322 - **	
19	Brake bushing	1	-	B10113 - **		B10226 - **		B10314 - **	
20	Selflocking nut	1	B10033 - **	B10116 - **		B10211 - **		B10315 - **	
21	Adapter	1	See chapter 3.2.9.5 ADAPTER						
Standard gas valve ass. (parts 3 ÷ 7)		1	V 2003 - ** / *	V 2027 - 1 - ** / *	V 2027 - ** / *		V 2048 - ** / *	V 2073 - ** / *	
Standard fluid port ass. (parts 9 ÷ 20)		1	V 2004 - *** - ** / *	V 2023 - *** - ** / *	V 2024 - *** - ** / *	V 2025 - *** - ** / *	V 2044 - *** - ** / *	V 2064 - *** - ** / *	
Gasket sets		1	B2010-1* { 0010R4112* B10038-T	B2030-1* { 0010R4150* B10133-T B10129-R 0010R2093*		B2031-1* { 0010R0159* B10150-T B10129-R 0010R3150*		B2050-1* { 0010R6212* B10227-T B10129-R 0010R3150*	B2080-1* { 0010R0181* B10320-T 0010T14-1/4* 0010R3218*

* Gasket material ** Component material *** See chapter 3.2.8 table 6 - 7

3.2gb

3.2.10. AST VERSION SPARE PARTS CODE


3.2gc

Item	Description	Q.ty	Type						
			AST 0,2	AST 0,7	AST 1 - 1,5	AST 3	AST 5	AST 10 + 55	
1	Accumulator shell	1	Not supplied as spare part						
2	Bladder	1	-	S0.7 *-0	S1*-0 / S1.5*-0	S3* -0	S5* -0	S10 + 55* -0	
3	Gas valve body	1	-	B10107T - **			B10219 - **	B10420 - **	
4	Rubber-coated washer	1	-	B10104 - ** / *	B10106 - ** / *		B10205 - ** / *	B10334 - ** / *	
5	Gas valve looknut	1	-	B10109 - **				B10302 - ** / *	
6	Holed pipe	1	-	B10141 - **		B10142 - **	B10220 - **	AST 10-15 = B10409 - 3 - ** AST 20-25 = B10409 - 4 - ** AST 35-55 = B10409 - 5 - **	
7	Spring	1	-	B10218-1 - **		B10218-2 - **	B10218 - **	AST 10-15 = B10411-1 - ** AST 20-25 = B10411-2 - ** AST 35-55 = B10411 - **	
8	Name plate	1	-	D10300A-A			D10300C-A	D10300E-A	
9	Retaining ring	1	-	B10127 - ** / *		B10146 - ** / *	B10222 - ** / *	B10317 - ** / *	
10	"O" ring	1	-	0010R4150 - *		0010R0159 - *	0010R6212 - *	0010R0181 - *	
11	Supporting ring	1	-	B10133-T		B10150-T	B10227-T	B10320-T	
12	Space ring	1	-	B10120 - **		B10223 - **		B10319 - **	
13	Fluid port ring nut	1	-	B10122 - **		B10217 - **		B10321 - **	
14	Bleed screw	1	-	B10128 - **				B10316A - **	
15	Seal ring	1	-	B10129-R				0010T14-1/4 - *	
16	Fluid port body std. version	1	-	B10115 - *** - **		B10144 - *** - **		B10311 - *** - **	
17	Poppet	1	-	B10111 - **		B10221 - **		B10310 - **	
18	Spring	1	-	B10112 - **		B10149 - **		B10322 - **	
19	Brake bushing	1	-	B10113 - **		B10226 - **		B10314 - **	
20	Selflocking nut	1	-	B10116 - **		B10211 - **		B10315 - **	
21	Adapter	1	-	See chapter 3.2.9.5 ADAPTER					
Standard gas valve ass. (parts 3 ÷ 7)			1	-	V 2456 - ** / *	V 2026 - ** / *	V 2029 - ** / *	V 2043 - ** / *	AST 10-15 = V 2065 - ** / * AST 20-25 = V 2066 - ** / * AST 35-55 = V 2067 - ** / *
Standard fluid port ass. (parts 9 ÷ 20)			1	-	V 2024 - *** - ** / *		V 2025 - *** - ** / *	V 2044 - *** - ** / *	V 2064 - *** - ** / *
Gasket sets			1	-	B2030-1-*	{ 0010R4150-* B10133-T B10129-R 0010R2093-*	{ 0010R0159-* B10150-T B10129-R 0010R3150-*	{ 0010R6212-* B10227-T B10129-R 0010R3150-*	{ 0010R0181-* B10320-T 0010T14-1/4-* 0010R3218-*

* Gasket material ** Component material *** See chapter 3.2.8 table 6 - 7

3.2gd

3.2.11 COMMISSIONING AND MAINTENANCE

Delivery conditions

The bladder accumulators' type ASL and AST cannot be delivered with the pre-charge.

Depending on the size and quantity ordered, the accumulators are shipped in boxes or in cartons or on pallets, or wooden boxes on request. Unless otherwise required, certificates and documentation are provided together with the accumulators.

Handling

The original packaging is suitable for handling and general storage. Where necessary, you should use suitable lifting equipment to support the weight of the accumulators. However protect from impact the packaging and handle it with care.

Storage

During storage in the warehouse, leave the product in its original packaging, keeping it away from heat sources and naked flames. The storage temperature should be between +10 and +40°C.

In addition to six months of storage, the precharge pressure must be to two bar and make sure that inside there is lubrication fluid compatible with bladder polymer.

After six years of storage, it is essential to proceed with the replacement of all elastomeric parts before the commissioning.

Marking on the nameplate of the accumulator

With reference to the PED 97/23/EC classification, Article 3, Paragraph 3 and / or risk categories I or II depending on the volume and maximum working pressure, the accumulator indicates the following data:

- Logo, name and country of the manufacturer
- Month/year of production
- Product code
- Serial number
- Maximum PS pressure and PT test pressure in bar
- Min. and max. TS working temperature in Celsius
- Volume V in litres
- Group of fluids allowed (II)
- CE marking (for volumes exceeding 1 litre) with the identification number of the notified body

It is strictly forbidden to:

- weld, rivet or screw any item of the accumulator
- engrave or permanently stamp the surfaces of the accumulator shell and / or carry out other operations that could affect or change the mechanical properties of the accumulator
- use the accumulator as a structural element: it should not be subjected to stresses or loads
- change the data of the nameplate and / or accumulator without the permission of the manufacturer
- use a (dangerous) fluid of Group 1 with equipment designed and manufactured for fluids of Group 2.

Installation

Before installation, you must perform a visual check to verify that the accumulator has not suffered any damage during shipping / handling.

Verify that the requested type matches with what stamped on the nameplate. We recommend using the accumulator with a suitable lock-off and security block type BS (see Chap. 9). This device provides the user pro-

tection and equipment against damage caused by pressure peaks, and also makes easy and safe the maintenance of the accumulator, so simplifying the interception and discharging. The accumulators type AS may be installed in any position from horizontal to vertical (preferably with the gas valve at the top), and the nameplate must be visible. Proceed to the assembly so that no abnormal force affects the pipes connected directly or indirectly to the accumulator, so we recommend the use of supporting components and also fastening (please see Chapter 7) to avoid the transmission of vibrations. If are not used EPE safety blocks, make sure that the accumulator is connected to the hydraulic circuit by suitable connection devices. Make sure the fluid is compatible with the elastomer of the bladder. Check that the max. allowed accumulator pressure is equal to or greater than that of the hydraulic circuit and that the temperature during operation is maintained within the range expected. Make sure the fluid does not contain contaminants and/or abrasive.

Pre-charge of nitrogen (type AST)

The pre-charge of gas should be performed after the connection to the additional bottles and after the installation of the accumulator in the hydraulic circuit. For the pre-charge, use only industrial dry nitrogen with a purity of min. 99%. It is important to use the nitrogen from a bottle equipped with a pressure reducing valve (see Chap.11.3). Use the EPE pre-charge and charging set type PC to check the charging pressure required, and adjust if necessary. If the pre-charge pressure is lower than required, connect the charging hose on one side and the other side connect it to the nitrogen bottle or to the pressure reducer. Slowly fill enter the nitrogen in the accumulator until reaching a pressure slightly higher than that set value (+ 10 ÷ 15%). Close the bottle and remove the charging hose from the pre-loading set; wait until the gas temperature has stabilized (2 hours) and calibrate the pressure, discharging the excess gas.

Make sure that the pre-charge valve, fittings, pipes and anything else are not subject to losses, by using, if necessary, soap and water.

Tighten the protective caps manually.

Hydraulic pressurization

- Check that the pre-charge pressure is adequate for the application
- Ensure that the hydraulic pressure never exceeds the max allowed pressure (PS) shown on the accumulator shell.

To avoid this risk, use a safety device (see Chap. 9).

Maintenance

- Periodically check the pre-charge pressure of the gas: after the commissioning, check after 2-3 weeks of operation and if there were no leaks, repeat the operation after 3 months; if the pressure at the same temperature was stable, repeat the test yearly. For heavy-duty applications, check the pre-charge every 6 months.
- Periodically (yearly) carry out a visual inspection of the accumulator in order to detect any early signs of deterioration such as corrosion, deformation, etc.
- Comply with the requirements of the regulations concerning the verification of the functionality of the equipment according to the country of installation of the accumulator.

Repair

If for failure, scheduled check or retest it is necessary to remove the accumulator from the system, prior to removal, isolate the accumulator from the installation and discharge pressure of the liquid. All bladder EPE accumulators of the ASL and AST series may be repaired.

It may consist in replacing the bladder, the seals, the pre-charge valve (AST) and/or the parts of the gas and fluid valve.
For reasons of functionality and security, it is recommended to use only original spare parts.

Disassembly

- Fasten the accumulator firmly in a vice or on a bench in a horizontal position, taking care not to damage the outer surface.



3.2h

- Remove gas valve, fastening the nut on the gas valve and remove the nameplate



3.2i

- Undo slotted round nut for hook wrench by using the hook wrench.



3.2j

- Remove the slotted nut and the retaining ring



3.2k

- Push enough oil valve into the housing until the sealing ring and the washer can be removed.



3.2l

- Remove the sealing ring and the washer



3.2m

- Remove the retaining ring, take it out, by carefully pushing the ring together.



3.2n

- Remove the oil valve from the container



3.2o

- Fold bladder somewhat and withdraw by turning it slightly



3.2t

- Carefully moisten the inside of the bladder and the container with used medium (roll container)

Refitting

Tightening torques in Nm				
	0.2 l	0.7-1.5 l	3 - 5 l	10-55 l
Fluid port ring nut	60 +10	100 +20	200 +50	450 +50
Bleed screw	3 +1	5 +1	5 +1	30 +10
Gas valve locknut	50 +10	80 +20	100 +20	150 +30
Filling valve V - VX - V2	-	-	-	30 +5

3.2p

- Cleaning and testing : clean all metallic parts on accumulator using an organic reducer – visual inspection of oil valve parts (valve tappet, spring, nut, damping screw) – check valve for sluggishness – Clean bladder, i.e. using isopropanol. Visual inspection of bladder for faults – inner inspection of container for signs of corrosion. In event of coated containers, check the condition of the coating. Replace the parts deemed to be bad; the o-rings must always be replaced (see spare parts Section 3.2.10).



3.2u

- Reinstall according to this sequence: o-ring, washer and spacer sleeve.



3.2s

- Drain air from bladder by pressing together



3.2v

- Screw the slotted nut and centre the parts on the oil valve by using a plastic hammer



3.2w

- Bleed screw with sealing ring



3.2z

- Mount the filling valve (AST)

Pre-charge (AST) after having fitted the accumulator on the system and having connected it to the additional cylinders.

- Screw the pre-charge PC equipment on the gas valve.
- Connect the equipment to the cylinder of nitrogen or to the pressure reducer with the inflation tube.
- Slowly enter the nitrogen in the accumulator until reaching a pressure slightly higher than the set value (+ 10 ÷ 15%).
- Close the cylinder and remove the connecting pipe from the equipment.
- Wait until the gas temperature has stabilized (2 hours).
- Calibrate the pressure discharging the excess gas.

Make sure that the gas valve, the fittings and the pipes are not subject to losses and, if necessary, use soap and water.

Tighten the protective caps manually.

Demolition and recycling of the accumulator

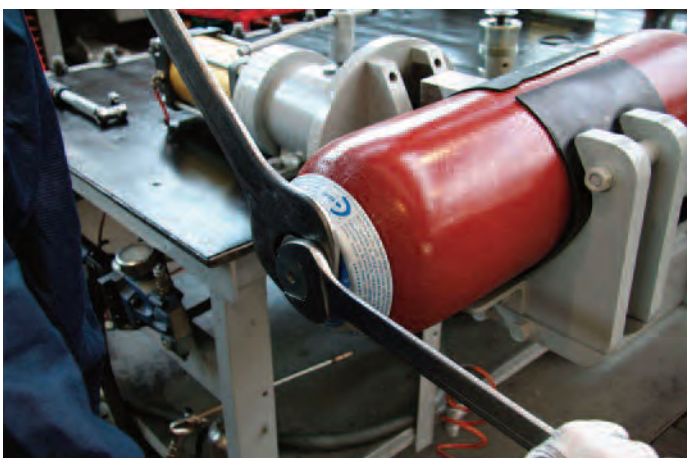
Before accumulator demolition or recycling, you should always discharge completely the pre-charge pressure and remove the gas valve (AST).

If needed, proceed decontaminating in relation to the fluid used prior to demolition.



3.2x

- Mount the bleed screw with its sealing ring



3.2y

- Tighten the hexagon nut SW1 on the gas valve

3.2.12 REPAIR TOOLS

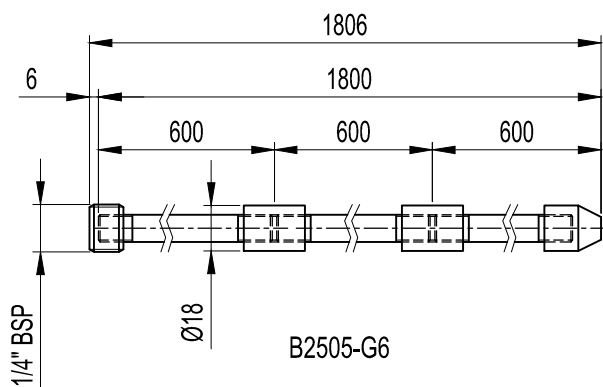
3.2.12.1 BLADDER PULL ROD

The pull rod screwed to the gas valve of the bladder for easy assembly into shell during reassembly. Pull rod is complete with fitting for EPE gas valve and 3 extension segments to accommodate all size of accumulators.

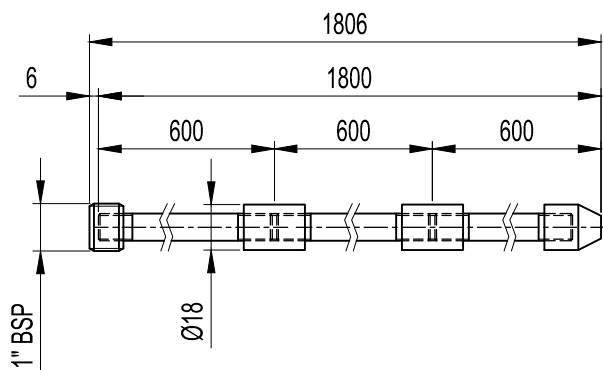
Code for complete kit: B2505-G2 / B2505-G6

Dimension

B2505-G2



B2505-G6



3.2aa

3.2.12.3 LIFTING HOOK

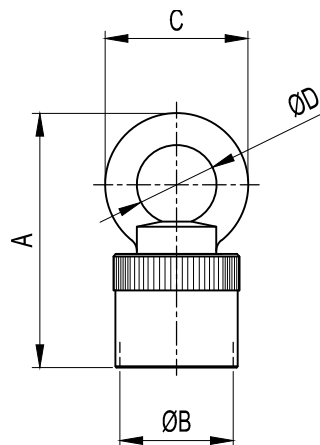
To be used for the safe lifting of mounted accumulators:

For accumulators 0,7÷5 lt (M22x1,5) code B2507/2

For accumulators 10÷55 lt (M50x1,5) code B2507/5

For accumulators V4 (7/8" UNF) code B2507/7

Dimension



3.2ac

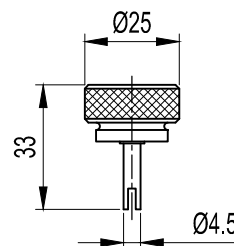
CODE	A	ØB	C	ØD	For Accumulator
B2507/2	100	M22x1,5	63	35	0,7 ÷ 1,5
B2507/5	112	M50x1,5	63	35	3 ÷ 5
B2507/7	100	7/8" UNF	63	35	10 ÷ 55

3.2.12.4 CORE TOOL

The core tool is used to remove and reinstall the valve core type V4.

Code B2508

Dimension



3.2ad

3.2.12.2 SPANNER WRENCH

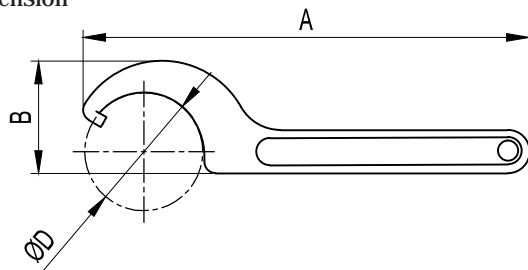
Fits all standard size bladder accumulator, it is used to remove or install lock nut on fluid port assembly.

0,7÷1,5 lt code 2506/58

3÷5 lt code 2506/68

10÷55 lt code 2506/105

Dimension



CODE	A	B	ØD	For Accumulator
B2506/58	241	45	58	0,7 ÷ 1,5
B2506/68	241	43	68	3 ÷ 5
B2506/105	336	82	105	10 ÷ 55

3.2ab

Reproduction is forbidden.

In the spirit of continuous improvement, our products may be changed.

3.3.1 TECHNICAL DATA

MAX OPERATING PRESSURE (PS): 60 bar

PRESSURE TEST (PT): 1.43 x PS

NOMINAL CAPACITIES:

0.7 - 1 - 1.5 - 3 - 5 - 10 - 15 - 20 - 25 - 35 - 55 litres

WORKING TEMPERATURE: -40 ÷ +150 °C

COMPRESSION RATIO (Po : P2): max. 1 : 4

FLUID VISCOSITY RANGE: 10 ÷ 400 cSt

RECOMMENDED VISCOSITY: 36 cSt

FLUID CONTAMINATION DEGREE:

class 21/19/16 according to ISO 4406/99

BODY MATERIAL:

- carbon steel shell painted with rust inhibitor RAL 8012
- nickel coating 25 - 40 µ
- stainless steel AISI 316L

VALVES MATERIAL:

- phosphated or galvanized carbon steel in compliance with Directive 2002/95/EC (RoHS) to resist to corrosion
- stainless steel AISI 316L
- nickel coating 25-40 µ

BLADDER MATERIAL:

- P = Nitrile rubber (NBR)
- F = Low temp. nitrile rubber
- H = Nitrile for hydrocarbons
- K = Hydrogenated nitrile (HNBR)
- B = Butyl (IIR)
- E = Ethylene-propylene (EPDM)
- N = Chloroprene (Neoprene)
- Y = Epichlorohydrin (ECO)
- V = Fluorocarbon (FPM)

See Table 3.3c and/or Chapter 1.5

FILLING VALVE CONNECTION:

- 5/8"-UNF std
- 7/8" UNF
- 1/4" BSP

FLUID PORT CONNECTION: see 3.3db - 3.3eb - 3.3ec - 3.3fb

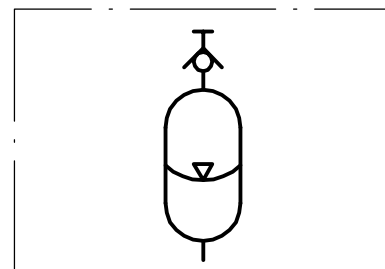
FLOW RATE: see Table 3.3db

WEIGHT: see Table 3.3db



3.3a

3.3.2 HYDRAULIC SYMBOL



3.3b

3.3.3 "ASB" BLADDER ADVANTAGES

- dirt tolerant
- light weight
- compact
- simple construction
- quick response
- works well on water, low lubricity fluids
- quick, easy installation
- low cost

3.3.4 DESCRIPTION

Bladder low pressure type accumulators consist of a welded cylindrical pressure vessel made of steel.

The accumulator is subdivided into a gas and fluid side by an elastic bladder mounted in the interior of the vessel.

The bladder is charged with nitrogen to the specified gas charge pressure P0 by means of gas valve.

When the fluid is pressed into the accumulator, the gas in the bladder is compressed and hence the pressure increased. The gas volume reduces and on the fluid side, the fluid can flow into the accumulator. As soon as the pressure on the fluid side falls below the gas pressure, the accumulator is emptied.

The special oil valve (anti-extrusion plate) prevents draining of the bladder into the oil channel and thus the bladder from being destroyed.

When the minimum operating pressure is reached, a small oil volume is to be maintained between the bladder and the fluid volume (approx. 10% of the nominal capacity of the hydraulic accumulator), in order that the bladder does not hit the valve during every expansion process.

Gas valve consists of external caps, sealing cap, filling valve, gas valve body and rubber coated washer. These parts can be replaced separately.

The nameplate shows the technical data and features of the hydraulic accumulator.

3.3.5 EUROPE MARKET

All hydraulic accumulators are pressure vessels and are subject to the national regulations and directives, valid at the place of installation.

Bladder accumulator type ASB, up to and including 1 litre, must not be CE marked.

For bladder accumulator type ASB, greater than 1 litre, every shipping batch is complete of a conformity declaration and instruction of use and maintenance and/or all documents requested.

All vessel categories (see Table 3.3db) must be protected by means of a pressure relief valve in accordance with Directive 97/23/EC.

3.3.6 ACCESSORIES

For support equipment, see Cap. 7

For gas side's safety equipment, see Cap. 8

For fluid side's safety equipment, see Cap. 9

For pre-loading and charging set, see Cap. 11

For other components, see Cap. 12

3.3.7 BLADDER-TEMPERATURE-LIQUID COMPATIBILITY

When selecting the accumulator variant, pay attention to the following non-binding notes with regard to hydraulic fluid, bladder material and the permissive temperature range. (see Section 1.5)

Code letter	Polymer	ISO	Temperature range (°C)	Some of the liquids compatible with the polymer
P	Standard nitrile (Perburan)	NBR	-20 ÷ +80	Aliphatic hydrocarbons (propane, butane, gasoline, oils, mineral greases, diesel fuel, fuel oil, kerosene), mineral greases and oils, HFA - HFB - HFC fluids, many dilute acids, alkalis, saline solutions, water, water glycol.
F	Low temperature nitrile	NBR	-40 ÷ +70	The same as with standard nitrile + a number of different types of Freon. (This contains less acrylonitrile than the standard and is therefore more suitable for low temperatures, but its chemical resistance is slightly lower).
H	Nitrile for hydrocarbons	NBR	-10 ÷ +90	Regular and premium grade slightly aromatic gasoline (and all the liquids for standard nitrile).
K	Hydrogenated nitrile	HNBR	-30 ÷ +130	The same as with standard nitrile but with excellent performance at high and low temperatures.
B	Butyl	IIR	-30 ÷ +100	Hot water up to 100°C, glycol-based brake fluids, many acids and bases, salt solutions, polar solvents such as alcohols, ketones and esters, polyglycol-based hydraulic fluids (HFC fluids) and bases of esters of phosphoric acid (HFD-R fluids), silicone oils and greases, Skydol 500 and 7000, resistance to ozone, aging and weathering.
E	Ethylene-Propylene	EPDM	-30 ÷ +100	Hot water up to 100°C, glycol-based brake fluids, many organic and inorganic acids, detergents, solutions of sodium and potassium, phosphate ester-based hydraulic fluids, (HFD-R), silicone oils and greases, many polar solvents (alcohol, ketones, esters), Skydol 500 and 7000, resistance to ozone, aging and weathering.
N	Chloroprene (Neoprene)	CR	-30 ÷ +100	Mineral oils of paraffin, silicone oils and greases, water and aqueous solutions, refrigerants (ammonia, carbon dioxide, Freon), naphthenic mineral oils, low molecular aliphatic hydrocarbons (propane, butane, fuel), brake fluids based on glycol, better resistance to ozone, weathering and aging compared to NBR rubber.
Y	Epichloridrin	ECO	-30 ÷ +110	Mineral oils and greases, aliphatic hydrocarbons (propane, butane and gasoline), silicone oils and greases, water at room temperature, resistance to ozone, aging and weathering.
V	Fluorocarbon	FPM	-10 ÷ +150	Mineral oils and greases, non-flammable fluids of HFD group, silicone oils and greases, animal and vegetable oils and greases, aliphatic hydrocarbons (gasoline, butane, propane, natural gas), aromatics hydrocarbons (benzene, toluene), chlorinated hydrocarbons (Tetrachloroethylene, carbon tetrachloride), fuel (regular, super and containing methanol), excellent resistance to ozone, weathering and aging.

For other hydraulic fluid and/or temperatures, please consult us.

3.3c

3.3.8 ORDER CODE

1	2	3	4	5	6	7-8	9	10	11	12	13	14	15	16	
ASB	55	P	30	C	R	G9	V	-	8	-	X	1	X	0	G30 / 10

<p>1 Series</p> <p>Bladder accumulator low pressure = ASB</p>	<p>16 Precharge pressure (bar)</p> <p>Standard 10 bar = 0 ÷ 15 (< PS)</p>
<p>2 Nominal capacity</p> <p>0.2 lt = 0.2 0.7 lt = 0.7 1 lt = 1 1.5 lt = 1.5 3 lt = 3 5 lt = 5 10 lt = 10 15 lt = 15 20 lt = 20 25 lt = 25 35 lt = 35 55 lt = 55</p>	<p>15 Other variants</p> <p>See the table on front page</p>
<p>3 Bladder material</p> <p>Nitrile rubber (NBR) = P Nitrile for low temp. = F Nitril for hydrocarbons = H Hydrogenated nitrile (HNBR) = K Butyl (IIR) = B Ethylene-propylene (EPDM) = E Chloroprene (Neoprene) = N Epichlorohydrin (ECO) = Y Fluorocarbon (FPM) = V</p>	<p>14 Variants of gas side</p> <p>Standard = 0 Only cap in stainless steel = 1 Brass nameplate = 2 Other numbers/variants to be requested EPE</p>
<p>4 Max working pressure (PS)</p> <p>See the table on front page</p>	<p>13 Gas valve material</p> <p>Carbon steel = C Nickel coated carbon steel 25 μ = N Nickel coated carbon steel 40 μ = M Stainless steel = X</p>
<p>5 Body material</p> <p>Carbon steel = C Nickel coated carbon steel 25 μ = N Nickel coated carbon steel 40 μ = M Stainless steel = X</p>	<p>12 Variants of fluid side</p> <p>Standard = 0 Adapter in stainless steel (R) = 1 Button and spring in stainless steel = 2 Other numbers/variants to be requested EPE</p>
<p>6 Fluid port connection</p> <p>0.7÷55 I BSP ISO 228 with chamfer for OR (std) = A 0.7÷55 I adapter * = R * assembled on the fluid valve connection type A</p>	<p>11 Fluid valve material</p> <p>Carbon steel = C Nickel coated carbon steel 25 μ = N Nickel coated carbon steel 40 μ = M Stainless steel = X</p>
<p>7-8 Dimension of the connection fluid or 7+8 table</p> <p>See the table on front page</p>	<p>10 Test and certification</p> <p>Factory testing = 0 TR (Russia) = 1 ML (China) = 3 PED97/23/EC (for capacities greater than 1 l) = 8 ATEX 94/9EC = 9 RTN Passport (Ukraine) = 11 Algeria passport = 12 Standard regulation (NR13) (Brazil) = 13 Tunisia passport = 14</p>
	<p>9 Connection gas side</p> <p>Standard filling valve 5/8" UNF thread = V Standard filling valve with 5/8" UNF thread in stainless steel = VX Without filling valve (thread hole M12x1.5) = V0 Brass filling valve 1/4" BSP = V2 Filling valve 7/8" UNF = V4</p>

Special variants upon request

4 Max working pressure (PS)		
Capacity litres	Carbon steel	Stainless steel
0.7 ÷ 5	60	40
10 ÷ 55	30 - 50 (other pressure related to connections B or U)	25 - 50

15 Other variants	
Adapter + Burst disc set at xxx bar (see Section 8.2)	= Rxxx
Adapter + Safety valve, type VS224TX set at xxx bar	= Gxxx
Adapter + Needle Valve of 1/4" BSP	= EG2
Adapter + Stainless steel needle Valve of 1/4" BSP	= EG2X
Adapter + Excluding device with with full scale pressure gauge of xxx bar	= EMxxx
Adapter + Excluding device of 90° with full scale pressure gauge of xxx bar	= ELMxxx
Flushing with degree of contamination ≤ x (NAS)	= Fx
75-80 μ thick. polyurethane paint with colour to be specified	= Wxxx
Off-shore paint with colour to be specified	= Zxxx
NORSOK System 1 paint with colour to be specified	= K1
NORSOK System 7 paint with colour to be specified	= K7
other variants upon request	

7 Dimension of the fluid connection	
For the type of connection:	
A (0.7 ÷ 5 l) 2"	= 9
(3 ÷ 5 l) 2" 1/2	= 10
(10 ÷ 55 l) 4"	= 13
B (0.7÷55 l)	DIMENSION/RATING
Former. 1" ANSI 150 = 1/150 (Pmax = 20 bar)	
U (0.7÷55 l)	DN/PN
Former. DN50 PN16 = 50/16 (Pmax = 16 bar)	
R (0.7÷55 l) Blind	= 0
R (0.7÷55 l) internal thread	= G*
BSP ISO 228	= P*
NPT-F	= N*
BSPT	
SAE	= S*
Metric	= M*
*Variant in table 8	

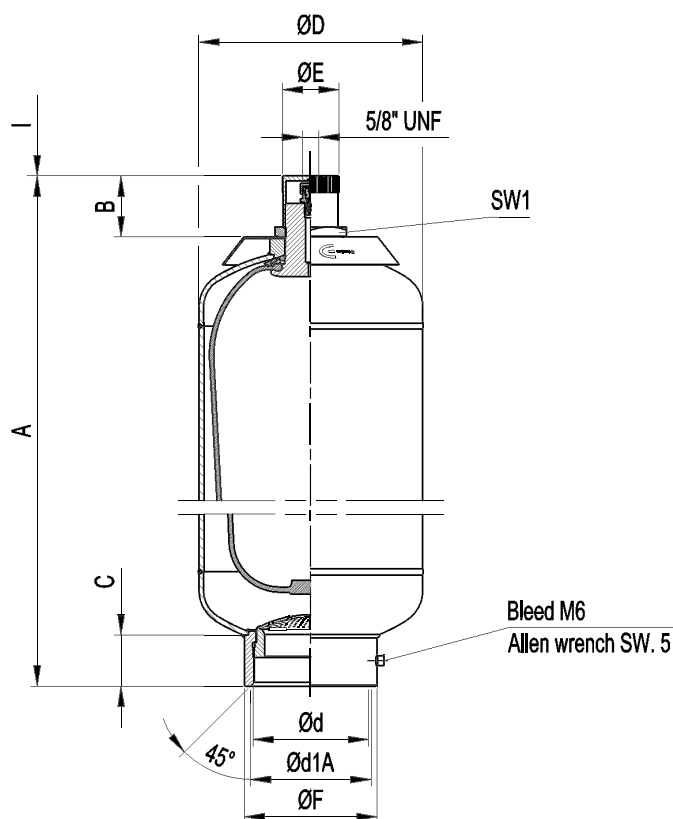
8 Dimension		
1/8" = 1	3/4" = 5	2" = 9
1/4" = 2	1" = 6	2" 1/2" = 10
3/8" = 3	1" 1/4" = 7	3" = 11
1/2" = 4	1" 1/2" = 8	3" 1/2" = 12

Dimension in inch - No.of pitch for inch

Diameter/pitch

Special variants upon request

3.3.9 DIMENSIONS



3.3da

Acc. type ASB in carbon steel	Nominal gas volume litres	Effective gas volume litres	Working pressure bar	Ped category liquids of group 2	Max.diff. pressure P2-P1 bar	Flow rate l/min	Max.comp. ratio P0/P2	A mm	B mm	C mm	Ø D mm	Ø d BSP	Ø d1 mm	Ø E mm	Ø F mm	I mm	SW 1 mm	Acc. dry weight kg
ASB 0.7	0.7	0.7	60 (40)	I	5	100	1:4	235 ±3	47	46	89	1" 1/2	54	25	60	140	32	2.4
ASB 1	1	1	60 (40)	I	5	100	1:4	253 ±3	45	41	114	1" 1/2	54	25	60	140	32	4.2
ASB 1,5	1,5	1,5	60 (40)	I	5	100	1:4	330 ±3	47	45	114	2"	63.35	25	75	140	32	4.8
ASB 3	3	2,95	60 (40)	II (I)	5	100	1:4	510 ± 5	47	45	114	2"	63.35	25	75	140	32	5.5
ASB 5	5	5	60 (40)	II (I)	5	150	1:4	420 ± 10	47	46	168	2" 1/2	79	25	88	140	32	11
ASB 10	10	9,1	30 (25+50)	I	5	300	1:4	475 ± 10	60	50	219	4"	118.4	55	130	140	70	18
ASB 15	15	14,5	30 (25+50)	I	5	300	1:4	615 ± 10	60	50	219	4"	118.4	55	130	140	70	23
ASB 20	20	18,2	30 (25+50)	I	5	300	1:4	755 ± 10	60	50	219	4"	118.4	55	130	140	70	28
ASB 25	25	23,5	30 (25+50)	I	5	300	1:4	900 ± 15	60	50	219	4"	118.4	55	130	140	70	33
ASB 35	35	33,5	30 (25+50)	I	5	300	1:4	1285 ± 15	60	50	219	4"	118.4	55	130	140	70	47
ASB 55	55	50	30 (25+50)	I	5	300	1:4	1765 ± 15	60	50	219	4"	118.4	55	130	140	70	65

* Allen wrench

** Ex. wrench

3.3db

* The maximum differential pressure is the maximum allowable difference between the maximum pressure and the minimum working pressure (P2-P1) to have an infinite life cycle of the accumulator (greater than 2,000,000 cycles).

** Flow rate measured using mineral oil with viscosity of 36 cSt at 50°C and ΔP = 5 bar

3.3.9.1 FLANGE CONNECTION TYPE ANSI / UNI DIN (B/U)

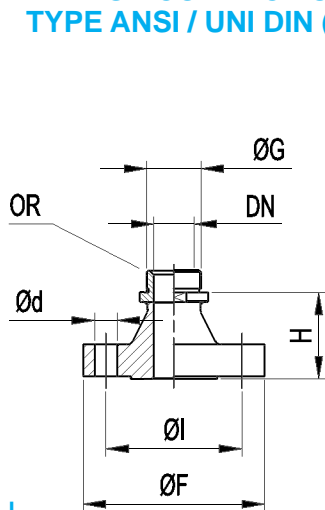


Fig. I

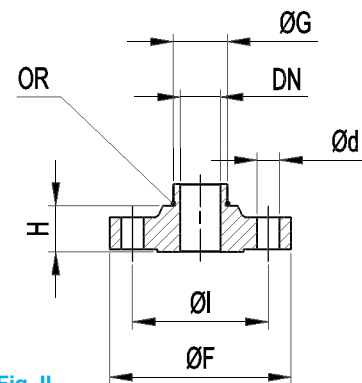
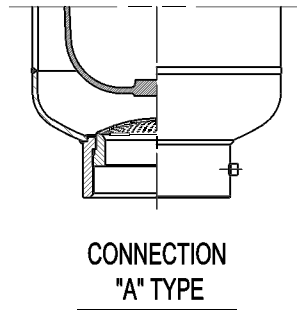


Fig. II

3.3ea

	Accumulator type	Spare flange order code	Ref. Directive		DN mm	PN bar	Fig.	Ø F mm	Ø I mm	Ød mm	N° Holes	H mm	G BSP	OR (Included)
			UNI	DIN										
U (UNI-DIN)	ASB 0.7 - 1	-	-	-	On request								-	-
	ASB 1.5 - 3	F 2222 - ** / *	2284	2635	25	40	I	115	85	14	4	51	2"	0010R3218-*
		F 2227 - ** / *	2284	2635	40	40	I	150	110	18	4	56		
		F 2231 - ** / *	2282	2633	50	16	II	165	125	18	4	23		
	ASB 5	F 2232 - ** / *	2285	2636	65	64	II	185	135	22	4	40	2" 1/2	0010R3281-*
		F 2241 - ** / *	2282	2633		16		185	145	18	4	23		
	ASB 10 ÷ 55	F 2242 - ** / *	2284	2635	50	40	I	165	125	18	4	65	4"	0010R4425-*
		F 2255 - ** / *	2282	2633		16		165	125	18	4	68		
		F 2256 - ** / *	2284	2635	40	165	125	18	4	68				
		F 2259 - ** / *	2282	2633	80	16	II	200	160	18	8	70		
F 2261 - ** / *		2282	2633	100	16	220		180	18	8	31			
F 2262 - ** / *	2284	2635	40	235	190	22	8	44						

* Gasket material

** Flange material

Others size on request

3.3eb

	Accumulator type	Spare flange order code	Ref. Directive	DN inch	PN lbs	Fig.	Ø F mm	Ø I mm	Ød mm	N° Holes	H mm	G BSP	OR (Included)
ASB 1.5 - 3	F 2225 - ** / *	B16.5	1" 300	I	123,5	88,9	19	4	73	2"	0010R3218-*		
	F 2229 - ** / *	B16.5	1" 1/2 300	I	155,6	114,3	22,2	4	79				
	F 2235 - ** / *	B16.5	2" 400	II	165	127	19	8	55				
ASB 5	F 2243 - ** / *	B16.5	2" 150	II	177,8	139,7	19	4	45	2" 1/2	0010R3281-*		
	F 2244 - ** / *	B16.5	300		190,5	149,2	22,2	8	52				
ASB 10 ÷ 55	F 2257 - ** / *	B16.5	2" 150	I	152,4	120,6	19	4	84	4"	0010R4425-*		
	F 2258 - ** / *	B16.5	300		165,1	127	19	8	90				
	F 2263 - ** / *	B16.5	4" 150	II	228,6	190,5	19	8	46				
	F 2264 - ** / *	B16.5	300		254	200	22,2	8	60				

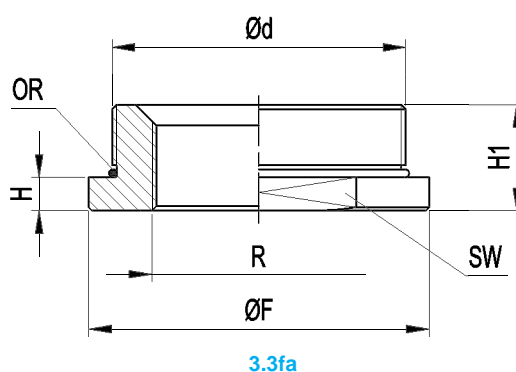
* Gasket material

** Flange material

Others size on request

3.3ec

3.3.9.2 ADAPTERS



Accumulator type	Order code	Ød Acc. connection	R**** Out connections (0 = blind)	SW mm	Ø F mm	H mm	H 1 mm	OR (Included)	Weight Kg
ASB 0,7 - 1	R - A8*** - ** / *	1" 1/2 BSP	1/8" + 1" 1/4 BSP - NPT - BSPT	65	70	15	45	0010R0156 - *	0,6
ASB 1,5 - 3	R - A9*** - ** / *	2" BSP	1/8" + 1" 1/2 BSP - NPT - BSPT	70	75	11	35	0010R3218 - *	0,86
ASB 5	R - A10*** - ** / *	2" 1/2 BSP	1/8" + 2" BSP - NPT - BSPT	80	88	20	44	0010R3281 - *	1,3
ASB 10 + 55	R - A13*** - ** / *	4" BSP	1/8" + 3" 1/2 BSP - NPT - BSPT	120	130	14	35	0010R4425 - *	3

* Gasket material

** Adapter material

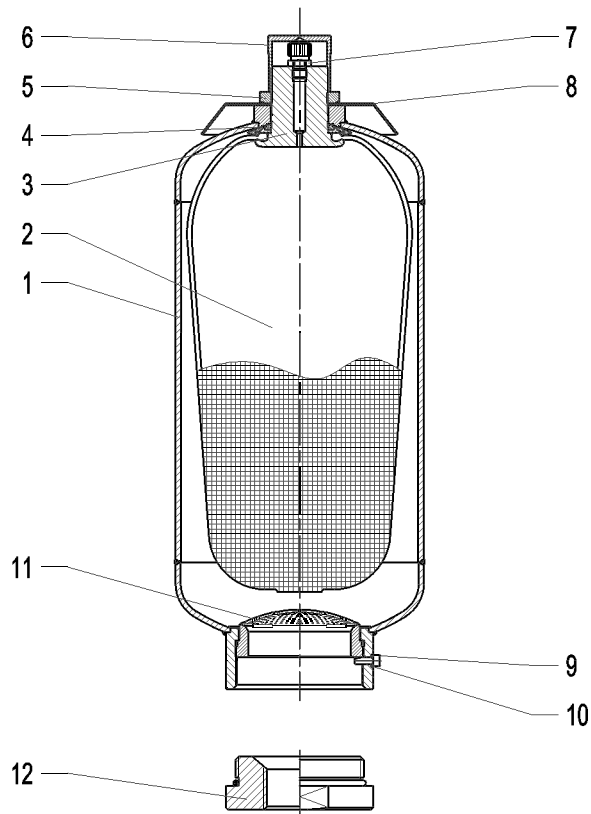
*** See chapter 3.3.8 table 7 - 8

Weigth indicated only for blind version

3.3fb

**** R Out connections type "S" and "M" thread on request

3.3.10. SPARE PARTS CODE



3.3ga

Item	Description	Q.ty	Type			
			ASB 0,7	ASB 1-1,5 - 3	ASB 5	ASB 10 ÷ 55
1	Accumulator shell	1	Not supplied as spare part			
2	Bladder	1	S0,7* - 0	S1* - 0 / S1.5* - 0 / S3* - 0	S5* - 0	S10 + 55* - 0
3	Gas valve body	1	B10107 - **		B10202 - **	B10333 - **
4	Rubber-coated washer	1	B10104 - ** / *	B10106 - ** / *	B10205 - ** / *	B10334 - ** / *
5	Gas valve looknut	1	B10109 - **			B10302 - **
6	Protection cap	1	B10103 - **			B10301 - **
7	Gas fill valve	1	V 2072 - ** - *			
8	Name plate	1	D10300A-A		D10300C-A	D10300E-A
9	Bleed screw	1	B10316 - **			
10	Seal ring	1	B10336 - R			
11	Anti-extrusion plate	1	B11426A - **1	B10159A - **1	B10241A - **1	B10421A - **
12	Adapter	1	See chapter 3.3.9.2 ADAPTER			
Standard gas valve ass. (parts 3 + 7)		1	V 2021 - ** / *	V 2022 - ** / *	V 2042 - ** / *	V 2062 - ** / *
Gasket sets		1	B2082-* <small>0010R2050-* B10341-P B10342-P 0010R4425-* B10336 - R</small>	B2032 - * <small>0010R2050-* B10341-P B10342-P 0010R3218-* B10336 - R</small>	B2052-* <small>0010R2050-* B10341-P B10342-P 0010R3281-* B10336 - R</small>	B2082-* <small>0010R2050-* B10341-P B10342-P 0010R4425-* B10336-R</small>

* Gasket material ** Component material

3.3gb

3.3.11 COMMISSIONING AND MAINTENANCE

Delivery conditions

Bladder accumulators type ASB are delivered pre-charged with nitrogen at a pressure of 10 bar or at value of pressure required at time of order. The pre-charge value is also on the nameplate of the accumulator.

Depending on the size and quantity ordered, the bladder accumulators are shipped in boxes, in cartons, on pallets or wooden boxes on request. Unless otherwise required, certificates and documentation are provided together with the accumulators.

Handling

The original packaging is suitable for handling and general storage. Where necessary, you should use suitable lifting equipment to support the weight of the accumulators.

However protect from impact the packaging and handle it with care.

Storage

During storage in the warehouse, leave the product in its original packaging, keeping it away from heat sources and naked flames. The storage temperature should be between +10 and +40°C.

In addition to six months of storage, the precharge pressure must be to two bar and make sure that inside there is lubrication fluid compatible with bladder polymer.

After six years of storage, it is essential to proceed with the replacement of all elastomeric parts before the commissioning.

Marking on the nameplate of the accumulator

With reference to the PED 97/23/EC classification, Article 3, Paragraph 3 and / or risk categories I or II depending on the volume and maximum working pressure, the accumulator indicates the following data:

- Logo, name and country of the manufacturer
- Month/year of production
- Product code
- Serial number
- Maximum PS pressure and PT test pressure in bar
- Min. and max. TS working temperature in Celsius
- Volume V in litres
- Group of fluids allowed (II)
- CE marking (for volumes exceeding 1 litre) with the identification number of the notified body
- Pre-charge pressure in bar

It is strictly forbidden to:

- weld, rivet or screw any item of the accumulator
- engrave or permanently stamp the surfaces of the accumulator shell and / or carry out other operations that could affect or change the mechanical properties of the accumulator
- use the accumulator as a structural element: it should not be subjected to stresses or loads
- change the data of the nameplate and / or accumulator without the permission of the manufacturer
- use a (dangerous) fluid of Group 1 with equipment designed and manufactured for fluids of Group 2.

Installation

Before installation, you must perform a visual check to verify that the accumulator has not suffered any damage during shipping / handling.

Verify that the requested type matches with what stamped on the nameplate. We recommend using the accumulator with a suitable security valve (see Chapter 8) or a security block type BS (see Chapter 9). This device provides user and equipment protection against possible damage caused by pressure surges and also makes the maintenance of the accumulator easier, facilitating the interception and the discharge. Provide for a space of 200 mm above the gas pre-charge valve to allow access to and control of the pre-charge equipment (see Chap.11.1). The accumulators type ASB may be installed in any position from horizontal to vertical (preferably with the pre-charge valve at the top), and the nameplate must be visible. Proceed to the assembly so that no abnormal force affects the pipes connected directly or indirectly to the accumulator, so we recommend the use of supporting components and also fastening (please see Chapter 7) to avoid the transmission of vibrations. If are not used EPE safety blocks, make sure that the accumulator is connected to the hydraulic circuit by suitable connection devices. Make sure the fluid is compatible with the elastomer of the bladder. Check that the max. allowed accumulator pressure is equal to or greater than that of the hydraulic circuit and that the temperature during operation is maintained within the range expected. Make sure the fluid does not contain contaminants and/or abrasive.

Pre-charge of nitrogen

Normally, the bladder accumulators are delivered pre-charged with pressurized gas. The pre-charge of gas can be controlled and / or adjusted before or after installation of the accumulator in the hydraulic circuit.

For the pre-charge, use only industrial dry nitrogen with a purity of min. 99%. It is important to use the nitrogen from a bottle equipped with a pressure reducing valve (see Chap.11.3). Use the EPE pre-charge and charging set type PC to check the charging pressure required, and adjust if necessary. If the pre-charge pressure is lower than required, connect the harging hose on one side and the other side connect it to the nitrogen bottle or to the pressure reducer. Slowly fill the nitrogen in the accumulator until reaching a pressure slightly higher than that set value (+ 10 ÷ 15%). Close the bottle and remove the charging hose from the pre-loading set; wait until the gas temperature has stabilized (2 hours) and calibrate the pressure, discharging the excess gas. Make sure that the gas valve is not subject to losses and, if necessary, use soap and water.

Tighten the protective caps manually.

Hydraulic pressurization

- Check that the pre-charge pressure is adequate for the application
- Ensure that the hydraulic pressure never exceeds the max pressure allowed (PS) shown on the accumulator shell.

To avoid this risk, use a safety device (see Chap. 9).

Maintenance

- Periodically check the pre-charge pressure of the gas: after the commissioning, check after 2-3 weeks of operation and if there were no leaks, repeat the operation after 3 months; if the pressure at the same temperature was stable, repeat the test yearly. For heavy-duty applications, check the pre-charge every 6 months.
- Periodically (yearly) carry out a visual inspection of the accumulator in order to detect any early signs of deterioration such as corrosion, deformation, etc.
- Comply with the requirements of the regulations concerning the verification of the functionality of the equipment according to the country of installation of the accumulator.

Repair

If for failure, scheduled check or retest it is necessary to remove the accumulator from the system, prior to removal, isolate the accumulator from the installation and discharge pressure of the liquid.

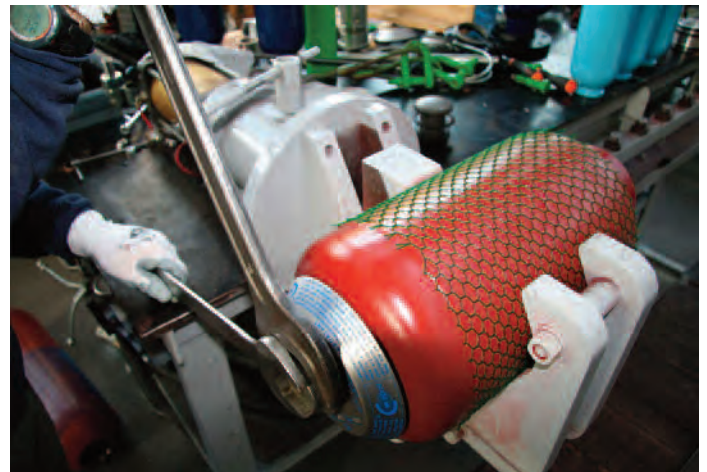
All bladder EPE accumulators of the ASB series may be repaired.

It may consist in replacing the bladder, the seals, the pre-charge valve and/or the parts of the gas and fluid valve.

For reasons of functionality and security, it is recommended to use only original spare parts.

Disassembly

- Fasten the accumulator firmly in a vice or on a bench in a horizontal position, taking care not to damage the outer surface.



3.3i

- Remove gas valve, fastening the nut on the gas valve and remove the nameplate



3.3h

- If you have not already carried out, unscrew the cap nut first and then the valve cap of the gas valve.



3.3m

- Unscrew the vent screw



3.3i

- Allow gas escapes from the bladder with the help of the check valve until a pressure of 0 is displayed. Check if the bladder is now de-pressurizing an open valve.



3.3n

- Using a suitable wrench, unscrew the fluid valve (anti-extrusion plate)



3.3o

- Remove the oil valve



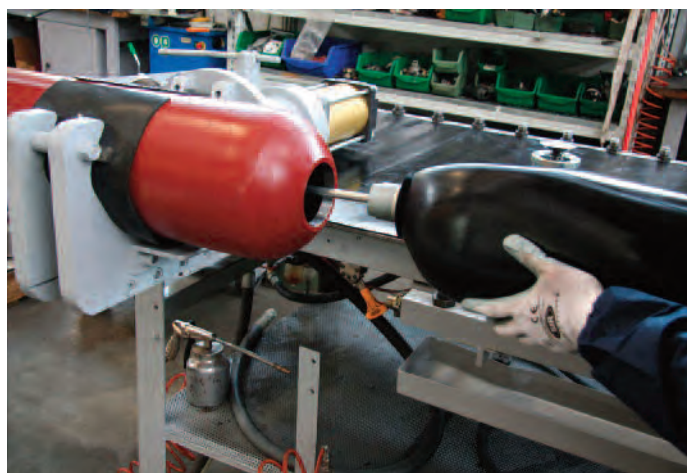
3.3q

- Drain air from bladder by pressing together



3.3p

- Fold bladder somewhat and withdraw by turning it slightly



3.3r

- Carefully moisten the inside of the bladder and the container with used medium (roll container)

Refitting

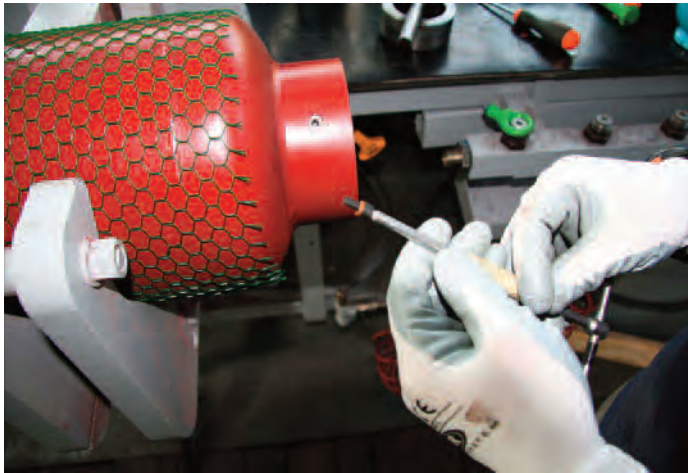
Tightening torques in Nm			
	0.7-1.5 l	3 - 5 l	10-55 l
Fluid port ring nut	100 +20	200 +50	450 +50
Bleed screw	5 +1	5 +1	30 +10
Gas valve locknut	80 +20	100 +20	150 +30
Filling valve V - VX - V2	30 +5	30 +5	30 +5
Valve insert V4	0.3 +0.,2	0.3 +0.2	0.3 +0.2

- Cleaning and testing: clean all metallic parts on accumulator using an organic reducer – visual inspection of valves– Clean bladder, i.e. using isopropanol. Visual inspection of bladder for faults – inner inspection of container for signs of corrosion. In event of coated containers, check the condition of the coating. Replace the parts deemed to be bad; the o-rings must always be replaced (see spare parts Section 3.3.9).



3.3s

- Install the anti extrusion plate.



3.3t

- Mount the bleed screw with its sealing ring



3.3u

- Tighten the hexagon nut SW1 on the gas valve



3.3v

- Mount the filling valve

Pre-charge



3.3z

- Screw the pre-charge PC equipment on the gas valve.
- Connect the equipment to the cylinder of nitrogen or to the pressure reducer with the inflation tube.
- Slowly enter the nitrogen in the accumulator until reaching a pressure slightly higher than the set value (+ 10 ÷ 15%).
- Close the cylinder and remove the connecting pipe from the equipment.
- Wait until the gas temperature has stabilized (2 hours).
- Calibrate the pressure discharging the excess gas.

Make sure that the gas valve is not subject to losses and, if necessary, use soap and water.

Tighten the protective caps manually.

Demolition and recycling of the accumulator

Before accumulator demolition or recycling, you should always discharge completely the pre-charge pressure and remove the gas valve.

If needed, proceed decontaminating in relation to the fluid used prior to demolition.

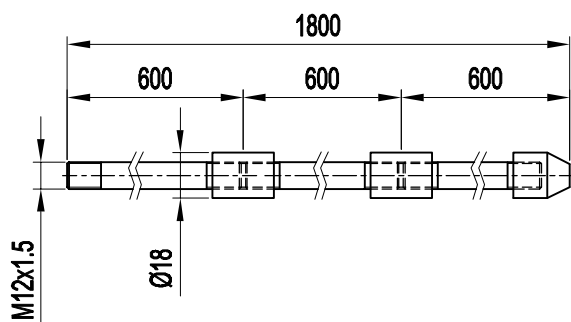
3.3.12 REPAIR TOOLS

3.3.12.1 BLADDER PULL ROD

The pull rod screwed to the gas valve of the bladder for easy assembly into shell during reassembly. Pull rod is complete with fitting for EPE gas valve and 3 extension segments to accommodate all size of accumulators.

Code for complete kit: B2505

Dimension

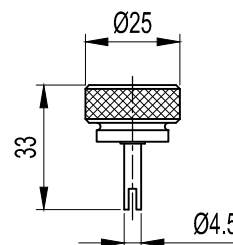


3.3aa

3.3.12.3 CORE TOOL

The core tool is used to remove and reinstall the valve core type V4. Code B2508

Dimension



3.3ac

3.3.12.2 LIFTING HOOK

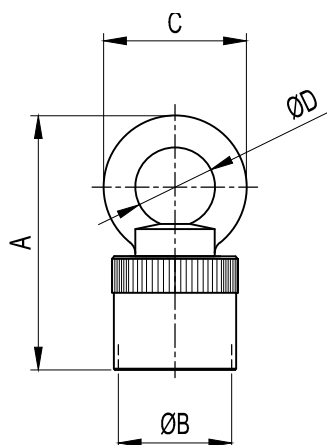
To be used for the safe lifting of mounted accumulators:

For accumulators 0,7÷5 lt (M22x1,5) code B2507/2

For accumulators 10÷55 lt (M50x1,5) code B2507/5

For accumulators type V4 (7/8" UNF) code B2507/7

Dimension



3.3ab

CODE	A	ØB	C	ØD	For Accumulator
B2507/2	100	M22x1.5	63	35	0.7 ÷ 1.5
B2507/5	112	M50x1.5	63	35	3 ÷ 5
B2507/7	100	7/8" UNF	63	35	10 ÷ 55

Reproduction is forbidden.

In the spirit of continuous improvement, our products may be changed.

3.4.1 TECHNICAL DATA

MAX OPERATING PRESSURE (PS): 60 bar

PRESSURE TEST (PT): 1.43 x PS

NOMINAL CAPACITIES:

ASBL: 0.7 - 1 - 1.5 - 3 - 5 - 10 - 15 - 20 - 25 - 35 - 55 litres

ASBT: 1 - 1.5 - 3 - 5 - 10 - 15 - 20 - 25 - 35 - 55 litres

WORKING TEMPERATURE: -40 ÷ +150 °C

FLUID VISCOSITY RANGE: 10 ÷ 400 cSt

RECOMMENDED VISCOSITY: 36 cSt

FLUID CONTAMINATION DEGREE:
class 21/19/16 according to ISO 4406/99

BODY MATERIAL:

- carbon steel shell painted with rust inhibitor RAL 8012
- nickel coating 25 - 40 µ
- stainless steel AISI 316L

VALVES MATERIAL:

- phosphated or galvanized carbon steel in compliance with Directive 2002/95/EC (RoHS) to resist to corrosion
- stainless steel AISI 316L
- nickel coating 25-40 µ

BLADDER MATERIAL:

- P = Nitrile rubber (NBR)
- F = Low temp. nitrile rubber
- H = Nitril for hydrocarbons
- K = Hydrogenated nitrile (HNBR)
- B = Butyl (IIR)
- E = Ethylene-propylene (EPDM)
- N = Chloroprene (Neoprene)
- Y = Epichlorohydrin (ECO)
- V = Fluorocarbon (FPM)

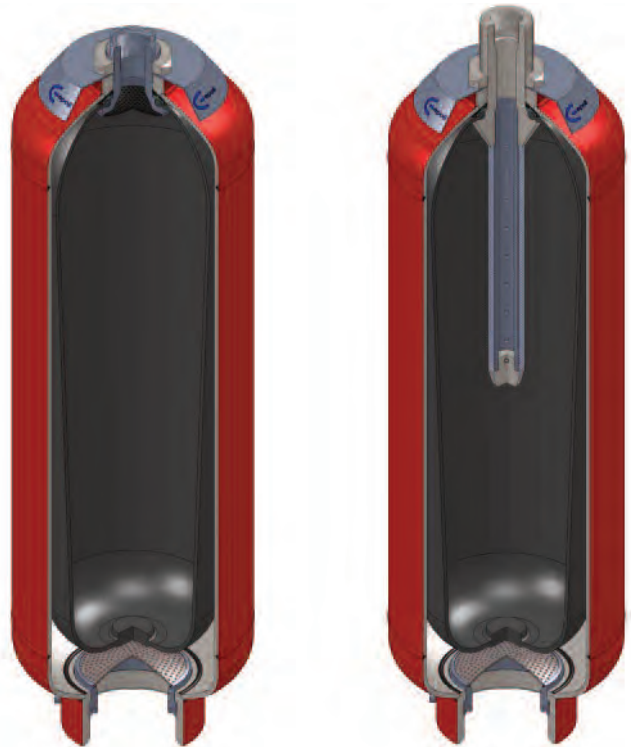
See Table 3.4c and/or Chapter 1.5

GAS VALVE CONNECTION: see Table 3.4db - 3.4dd

FLUID PORT CONNECTION: - see Table 3.4db - 3.4dd - 3.4eb
3.4ec - 3.4fb

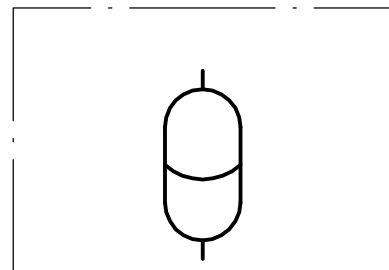
FLOW RATE: see Table 3.4db - 3.4dd

WEIGHT: see Table 3.4db - 3.4dd



3.4a

3.4.2 HYDRAULIC SYMBOL



3.4b

3.4.3 “ASBL and ASBT” BLADDER ADVANTAGES

- dirt tolerant
- light weight
- compact
- simple construction
- quick response
- works well on water, low lubricity fluids
- quick, easy installation
- low cost

3.4.4 DESCRIPTION

Bladder low pressure ASBL and ASBT type accumulators consist of a welded cylindrical pressure vessel made of steel.

The accumulators are subdivided into a gas and fluid side by an elastic bladder mounted in the interior of the vessel.

In the ASBL type, the liquid is also inside the bladder.

The transfer accumulator ASBT type is designed especially for connecting to nitrogen bottle. A diffuser rod prevents damages to the bladder when the accumulator works.

Nitrogen bottle used as back-ups increase the gas volume in the accumulator. This means that smaller accumulators can be used for the same gas volume and costs can be reduced.

When the fluid is pressed into the accumulator, the gas in the bladder is compressed and hence the pressure increased. The gas volume reduces and on the fluid side, the fluid can flow into the accumulator. As soon as the pressure on the fluid side falls below the gas pressure, the accumulator is emptied.

Oil valve is provided in the oil port of the bladder-type accumulator and closes when the pressure on the gas side is higher than the one on the fluid side. This prevents draining of the bladder into the oil channel and thus the bladder from being destroyed.

When the minimum operating pressure is reached, a small oil volume is to be maintained between the bladder and the fluid volume (approx. 10% of the nominal capacity of the hydraulic accumulator), in order that the bladder does not hit the valve during every expansion process.

The gas valve body of ASBL type accumulator is complete with anti-extrusion in addition to the rubber washer and locknut.

The gas valve body of ASBT type accumulator is complete with diffuser rod in addition to the rubber washer and locknut.

These parts can be replaced separately.

The nameplate shows the technical data and features of the hydraulic accumulator.

3.4.5 EUROPE MARKET

All hydraulic accumulators are pressure vessels and are subject to the national regulations and directives, valid at the place of installation.

Bladder accumulator type ASBL e ASBT, up to and including 1 liter must not be CE marked.

For bladder accumulator type ASBL e ASBT, greater than 1 liter, every shipping batch is complete of a conformity declaration and instruction of use and maintenance and/or all documents requested.

All vessel categories (see Table 3.4db, 3.4dd) must be protected by means of a pressure relief valve in accordance with Directive 97/23/EC.

3.4.6 ACCESSORIES

For additional cylinders, see Section 6

For support equipment, see Cap. 7

For gas side's safety equipment, see Cap. 8

For fluid side's safety equipment, see Cap. 9

For pre-loading and charging set, see Cap. 11

For other components, see Cap. 12

3.4.7 BLADDER-TEMPERATURE-LIQUID COMPATIBILITY

When selecting the accumulator variant, pay attention to the following non-binding notes with regard to hydraulic fluid, bladder material and the permissive temperature range. (see Section 1.5)

Code letter	Polymer	ISO	Temperature range (°C)	Some of the liquids compatible with the polymer
P	Standard nitrile (Perburan)	NBR	-20 ÷ +80	Aliphatic hydrocarbons (propane, butane, gasoline, oils, mineral greases, diesel fuel, fuel oil, kerosene), mineral greases and oils, HFA - HFB - HFC fluids, many dilute acids, alkalis, saline solutions, water, water glycol.
F	Low temperature nitrile	NBR	-40 ÷ +70	The same as with standard nitrile + a number of different types of Freon. (This contains less acrylonitrile than the standard and is therefore more suitable for low temperatures, but its chemical resistance is slightly lower).
H	Nitrile for hydrocarbons	NBR	-10 ÷ +90	Regular and premium grade slightly aromatic gasoline (and all the liquids for standard nitrile).
K	Hydrogenated nitrile	HNBR	-30 ÷ +130	The same as with standard nitrile but with excellent performance at high and low temperatures.
B	Butyl	IIR	-30 ÷ +100	Hot water up to 100°C, glycol-based brake fluids, many acids and bases, salt solutions, polar solvents such as alcohols, ketones and esters, polyglycol-based hydraulic fluids (HFC fluids) and bases of esters of phosphoric acid (HFD-R fluids), silicone oils and greases, Skydol 500 and 7000, resistance to ozone, aging and weathering.
E	Ethylene-Propylene	EPDM	-30 ÷ +100	Hot water up to 100°C, glycol-based brake fluids, many organic and inorganic acids, detergents, solutions of sodium and potassium, phosphate ester-based hydraulic fluids, (HFD-R), silicone oils and greases, many polar solvents (alcohol, ketones, esters), Skydol 500 and 7000, resistance to ozone, aging and weathering.
N	Chloroprene (Neoprene)	CR	-30 ÷ +100	Mineral oils of paraffin, silicone oils and greases, water and aqueous solutions, refrigerants (ammonia, carbon dioxide, Freon), naphthenic mineral oils, low molecular aliphatic hydrocarbons (propane, butane, fuel), brake fluids based on glycol, better resistance to ozone, weathering and aging compared to NBR rubber.
Y	Epichloridrin	ECO	-30 ÷ +110	Mineral oils and greases, aliphatic hydrocarbons (propane, butane and gasoline), silicone oils and greases, water at room temperature, resistance to ozone, aging and weathering.
V	Fluorocarbon	FPM	-10 ÷ +150	Mineral oils and greases, non-flammable fluids of HFD group, silicone oils and greases, animal and vegetable oils and greases, aliphatic hydrocarbons (gasoline, butane, propane, natural gas), aromatics hydrocarbons (benzene, toluene), chlorinated hydrocarbons (Tetrachloroethylene, carbon tetrachloride), fuel (regular, super and containing methanol), excellent resistance to ozone, weathering and aging.

For other hydraulic fluid and/or temperatures, please consult us.

3.4c

3.4.8 ORDER CODE

1	2	3	4	5	6	7-8	9	10	11	12	13	14	15		
ASBL	25	P	25	X	R	G10	G6	-	8	-	X	1	X	0	F6

<p>1 Series</p> <p>Bladder accumulator low pressure liquid separator = ASBL Bladder accumulator low pressure transfer = ASBT</p>	<p>15 Other variants</p> <p>See the table on front page</p>
<p>2 Nominal capacity</p> <p>0.7 lt = 0.7 1 lt = 1 1.5 lt = 1.5 3 lt = 3 5 lt = 5 10 lt = 10 15 lt = 15 20 lt = 20 25 lt = 25 35 lt = 35 55 lt = 55</p>	<p>14 Variants of gas side</p> <p>Standard = 0 Only cap in stainless steel = 1 Brass nameplate = 2 Other numbers/variants to be requested EPE</p>
<p>3 Bladder material</p> <p>Nitrile rubber (NBR) = P Nitrile for low temp. = F Nitril for hydrocarbons = H Hydrogenated nitrile (HNBR) = K Butyl (IIR) = B Ethylene-propylene (EPDM) = E Chloroprene (Neoprene) = N Epichlorohydrin (ECO) = Y Fluorocarbon (FPM) = V</p>	<p>13 Gas valve material</p> <p>Carbon steel = C Nickel coated carbon steel 25 μ = N Nickel coated carbon steel 40 μ = M Stainless steel = X</p>
<p>4 Max working pressure (PS)</p> <p>See the table on front page</p>	<p>12 Variants of fluid side</p> <p>Standard = 0 Adapter in stainless steel (R) = 1 Other numbers/variants to be requested EPE</p>
<p>5 Body material</p> <p>Carbon steel = C Nickel coated carbon steel 25 μ = N Nickel coated carbon steel 40 μ = M Stainless steel = X</p>	<p>11 Fluid valve material</p> <p>Carbon steel = C Nickel coated carbon steel 25 μ = N Nickel coated carbon steel 40 μ = M Stainless steel = X</p>
<p>6 Fluid port connection</p> <p>0.7÷55 I BSP ISO 228 with chamfer for OR (std) = A 0.7÷55 I adapter * = R * assembled on the fluid valve connection type A</p>	<p>10 Test and certification</p> <p>Factory testing = 0 TR (Russia) = 1 ML (China) = 3 PED97/23/EC (for capacities greater than 1 l) = 8 ATEX 94/9EC = 9 RTN Passport (Ukraine) = 11 Algeria passport = 12 Standard regulation (NR13) (Brazil) = 13 Tunisia passport = 14</p>
<p>7-8 Dimension of the connection fluid or 7+8 table</p> <p>See the table on front page</p>	<p>9 Connection gas side</p> <p>Capacity 0.7 ÷ 5 l = G2 Capacity 10 ÷ 55 l = G6</p>

Special variants upon request / Versioni speciali su richiesta

4 Max working pressure (PS)		
Capacity litres	Carbon steel	Stainless steel
0.7 ÷ 5 10 ÷ 55	60 30 - 50 (other pressure related to connections B or U)	40 25 - 50

6 Fluid port connection	
For ASxx 0.7÷55BSP ISO 228 with chamfer for OR (std)	= A
For ASxx 0.2 BSP ISO 228 (std)	= G
For ASxx 3÷55 Metric	= M
For ASxx 0.7÷55 NPT-F	= P
For ASxx 3÷55 internal thread SAE	= S
For ASxx 3÷55 adapter for flange SAE 3000 Psi	= L
For ASxx 3÷55 adapter for flange SAE 6000 Psi	= H
For ASxx 0.7÷55 flange ANSI	= B
For ASxx 0.7÷55 flange UNI	= U
For ASxx 0.7÷55 square flange	= Q
For ASxx 0.7÷55 adapter *	= R
* assembled on the fluid valve connection type A	

15 Other variants	
Rupture disc set at xxx bar, laterally on AST (see Section...)	= Rxxx
Needle Valve of ¼" BSP, laterally on AST	= EG2
Flushing with degree of contamination ≤ x	= Fx
75-80 μ thick polyurethane paint with colour to be specified	= Wxxx
Off-shore paint with colour to be specified	= Zxxx
NORSOK System 1 paint with colour to be specified	= K1
NORSOK System 7 paint with colour to be specified	= K7
other variants upon request	

7 Dimension of the fluid connection	
For the type of connection:	
A (0.7 ÷ 5 l) 2"	= 9
(3 ÷ 5 l) 2" 1/2	= 10
(10 ÷ 55 l) 4"	= 13
B (0.7÷55 l)	DIMENSION/RATING
Former. 1" ANSI 150 = 1/150 (Pmax = 20 bar)	
U (0.7÷55 l)	DN/PN
Former. DN50 PN16 = 50/16 (Pmax = 16 bar)	
R (0.7÷55 l) Blind	= 0
R (0.7÷55 l) internal thread	= G*
BSP ISO 228	= P*
NPT-F	= N*
BSPT	
SAE	= S*
Metric	= M*
*Variant in table 8	

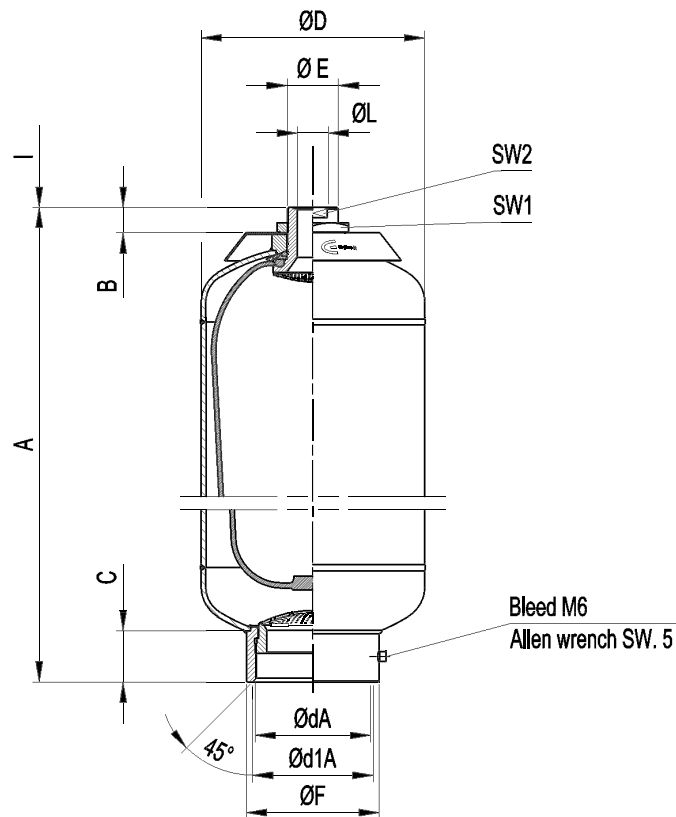
8 Dimension					
1/8"	= 1	3/4"	= 5	2"	= 9
1/4"	= 2	1"	= 6	2" ½"	= 10
3/8"	= 3	1" ¼"	= 7	3"	= 11
1/2"	= 4	1" ½"	= 8	3" ½"	= 12

Dimension in inch - No.of pitch for inch

Diameter/pitch

Special variants upon request

3.4.9 DIMENSIONS ASBL VERSION



3.4da

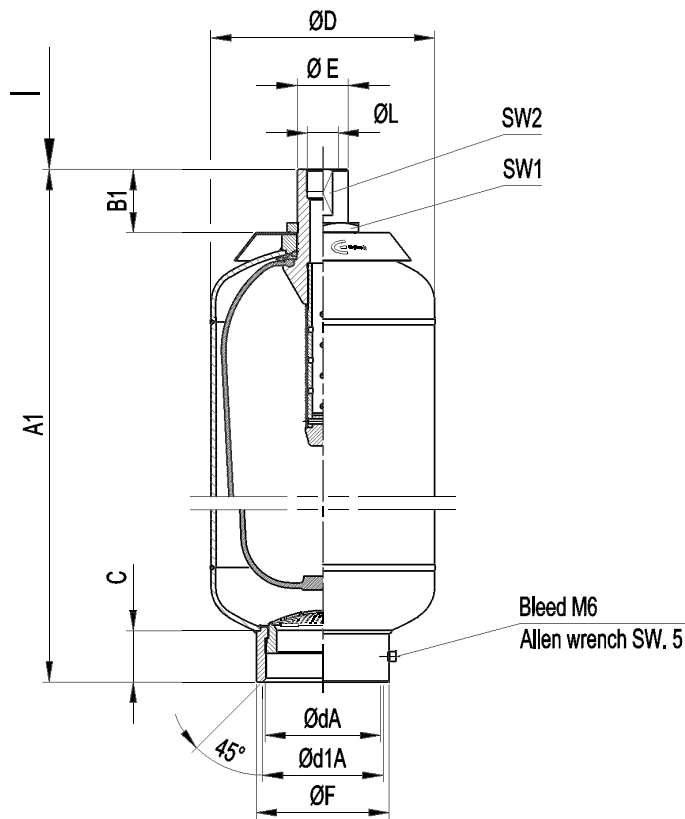
Acc. type ASBL in carbon steel	Nominal gas volume litres	Effective gas volume litres	Working pressure bar	Ped category liquids of group 2	Max.diff. pressure P2-P1 bar	Flow rate l/min	Max.comp. ratio P0/P2	A mm	B mm	C mm	$\varnothing D$ mm	$\varnothing d$ BSP	$\varnothing d1$ mm	$\varnothing E$ M	$\varnothing F$ mm	$\varnothing L$ BSP	I mm	SW 1 mm	SW 2 mm	Acc. dry weight kg
ASBL 0,7	0,7	0,7	60 (40)	I	5	100	1:4	209 ± 3	21	41	89	1" 1/2	54	22x1.5	60	1/4"	140	32	18	2.2
ASBL 1	1	1	60 (40)	I	5	100	1:4	228 ± 3	21	41	114	1" 1/2	54	22x1.5	60	1/4"	140	32	18	4
ASBL 1,5	1,5	1,5	60 (40)	I	5	100	1:4	297 ± 3	20	45	114	2"	63.35	22x1.5	75	1/4"	140	32	18	4.8
ASBL 3	3	2,95	60 (40)	II (I)	5	100	1:4	477 ± 3	20	45	114	2"	63.35	22x1.5	75	1/4"	140	32	18	5.5
ASBL 5	5	5	60 (40)	II (I)	5	150	1:4	392 ± 10	19	46	168	2" 1/2	79	22x1.5	88	1/4"	140	32	18	11
ASBL 10	10	9,1	30 (25+50)	II	5	300	1:4	443 ± 10	28	50	219	4"	118.4	50x1.5	130	1"	140	70	41	18
ASBL 15	15	14,5	30 (25+50)	II	5	300	1:4	583 ± 10	28	50	219	4"	118.4	50x1.5	130	1"	140	70	41	23
ASBL 20	20	18,2	30 (25+50)	II	5	300	1:4	723 ± 10	28	50	219	4"	118.4	50x1.5	130	1"	140	70	41	28
ASBL 25	25	23,5	30 (25+50)	II	5	300	1:4	868 ± 15	28	50	219	4"	118.4	50x1.5	130	1"	140	70	41	33
ASBL 35	35	33,5	30 (25+50)	II	5	300	1:4	1253 ± 15	28	50	219	4"	118.4	50x1.5	130	1"	140	70	41	47
ASBL 55	55	50	30 (25+50)	III	5	300	1:4	1733 ± 15	28	50	219	4"	118.4	50x1.5	130	1"	140	70	41	65

3.4db

* The maximum differential pressure is the maximum allowable difference between the maximum pressure and the minimum working pressure (P2-P1) to have an infinite life cycle of the accumulator (greater than 2,000,000 cycles).

** Flow rate measured using mineral oil with viscosity of 36 cSt at 50°C and $\Delta P = 5$ bar

ASBT VERSION



3.4dc

Acc. type ASBL in carbon steel	Nominal gas volume litres	Effective gas volume litres	Working pressure bar	Ped category liquids of group 2	Max.diff. pressure P2-P1 bar	Flow rate l/min	Max.comp. ratio P0/P2	A1 mm	B1 mm	C mm	Ø D mm	Ø d BSP	Ø d1 mm	Ø E M	Ø F mm	Ø L BSP	I mm	SW 1 mm	SW 2 mm	Acc. dry weight kg
ASBT 1,5	1,5	1,5	60 (40)	I	5	100	1:4	305 ± 3	28	45	114	2"	63.35	22x1.5	75	1/4"	140	32	18	4.8
ASBT 3	3	2,95	60 (40)	II (I)	5	100	1:4	485 ± 3	28	45	114	2"	63.35	22x1.5	75	1/4"	140	32	18	5.5
ASBT 5	5	5	60 (40)	II (I)	5	150	1:4	396 ± 10	23	46	168	2" 1/2	79	22x1.5	88	1/4"	140	32	18	11.2
ASBT 10	10	9,1	30 (25+50)	II	5	300	1:4	464 ± 10	49	50	219	4"	118.4	50x1.5	130	1"	140	70	46	18
ASBT 15	15	14,5	30 (25+50)	II	5	300	1:4	604 ± 10	49	50	219	4"	118.4	50x1.5	130	1"	140	70	46	23
ASBT 20	20	18,2	30 (25+50)	II	5	300	1:4	744 ± 10	49	50	219	4"	118.4	50x1.5	130	1"	140	70	46	28
ASBT 25	25	23,5	30 (25+50)	II	5	300	1:4	889 ± 15	49	50	219	4"	118.4	50x1.5	130	1"	140	70	46	33
ASBT 35	35	33,5	30 (25+50)	II	5	300	1:4	1274 ± 15	49	50	219	4"	118.4	50x1.5	130	1"	140	70	46	47
ASBT 55	55	50	30 (25+50)	III	5	300	1:4	1754 ± 15	49	50	219	4"	118.4	50x1.5	130	1"	140	70	46	65

3.4dd

* The maximum differential pressure is the maximum allowable difference between the maximum pressure and the minimum working pressure (P2-P1) to have an infinite life cycle of the accumulator (greater than 2,000,000 cycles).

** Flow rate measured using mineral oil with viscosity of 36 cSt at 50°C and ΔP = 5 bar

3.4.9.1 FLANGE CONNECTION TYPE ANSI / UNI DIN (B/U)

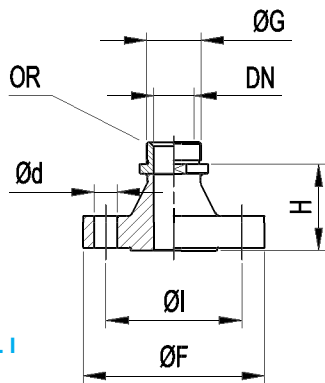


Fig. I

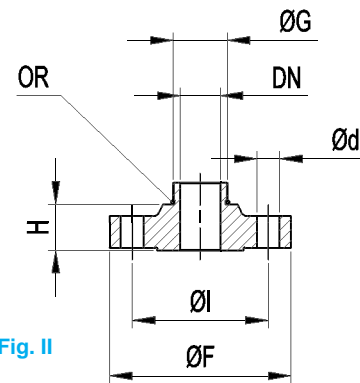
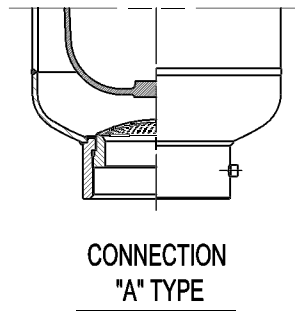


Fig. II

3.4ea

	Accumulator type	Spare flange order code	Ref. Directive		DN mm	PN bar	Fig.	Ø F mm	Ø I mm	Ø d mm	N° Holes	H mm	G BSP	OR (Included)
			UNI	DIN										
U (UNI-DIN)	ASBL / ASBT 1.5 - 3	F 2222 - ** / *	2284	2635	25	40	I	115	85	14	4	51	2"	0010R3218-*
		F 2223 - ** / *	6086	2628		250		150	105	22	4	76		
		F 2227 - .	2284	2635	40	40	I	150	110	18	4	56		
		F 2228 - ** / *	6086	2628		250		185	135	25	4	91		
		F 2231 - ** / *	2282	2633	50	16	II	165	125	18	4	23		
		F 2232 - ** / *	2285	2636		64		185	135	22	4	40		
	F 2233 - ** / *	6086	2628	250		200		150	25	8	61			
	ASBL / ASBT 5	F 2241 - ** / *	2282	2633	65	16	II	185	145	18	4	23	2" 1/2	0010R3218-*
		F 2242 - ** / *	2284	2635		40		185	145	18	8	30		
	ASBL / ASBT 10 ÷ 55	F 2255 - ** / *	2282	2633	50	16	I	165	125	18	4	65	4"	0010R4425-*
			2284	2635		40		165	125	18	4	68		
		F 2259 - ** / *	2282	2633	80	16	II	200	160	18	8	70		
		F 2261 - ** / *	2282	2633	100	16		220	180	18	8	31		
		F 2262 - ** / *	2284	2635		40		235	190	22	8	44		

* Gasket material

** Flange material

Others size on request

3.4eb

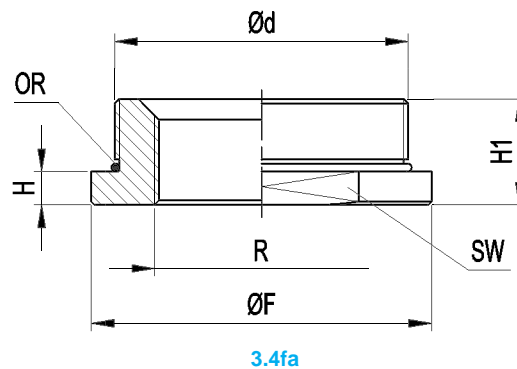
	Accumulator type	Spare flange order code	Ref. Directive	DN inch	PN lbs	Fig.	Ø F mm	Ø I mm	Ø d mm	N° Holes	H mm	G BSP	OR
B (ANSI)	ASBL / ASBT 1.5 - 3	F 2225 - ** / *	B16.5	1"	300	I	123,5	88,9	19	4	73	2"	0010R3218-*
		F 2226 - ** / *	B16.5		1500		149,5	101,6	25,4	4	90		
		F 2229 - ** / *	B16.5	300	1" 1/2	I	155,6	114,3	22,2	4	79		
		F 2230 - ** / *	B16.5	1500			178	123,8	28,5	4	100		
	ASBL / ASBT 5	F 2235 - ** / *	B16.5	400	2"	II	165	127	19	8	55	2" 1/2	0010R3281-*
		F 2236 - ** / *	B16.5	1500			216	165,1	25,4	8	83		
	ASBL / ASBT 10 ÷ 55	F 2243 - ** / *	B16.5	150	2" 1/2	II	177,8	139,7	19	4	45	4"	0010R4425-*
			B16.5	300			190,5	149,2	22,2	8	52		
		F 2257 - ** / *	B16.5	150	2"	I	152,4	120,6	19	4	84		
			B16.5	300			165,1	127	19	8	90		
F 2263 - ** / *	B16.5	150	4"	II	228,6	190,5	19	8	46				
	B16.5	300			254	200	22,2	8	60				

* Gasket material

** Flange material

Others size on request

3.4ec

3.4.9.2 ADAPTERS


Accumulator type	Order code	Ød Acc. connection	R**** Out connections (0 = blind)	SW mm	Ø F mm	H mm	H 1 mm	OR (Included)	Weight Kg
ASBL 0,7 - 1 / ASBT 1	R - A8*** - ** / *	1" 1/2 BSP	1/8" + 1" 1/4 BSP - NPT - BSPT	65	70	15	45	0010R0156 - *	0,6
ASBL \ ASBT 1,5 - 3	R - A9*** - ** / *	2" BSP	1/8" + 1" 1/2 BSP - NPT - BSPT	70	75	11	11	0010R3218 - *	0,86
ASBL \ ASBT 5	R - A10*** - ** / *	2" 1/2 BSP	1/8" + 2" BSP - NPT - BSPT	80	88	11	11	0010R3281 - *	1,3
ASBL \ ASBT 10 + 55	R - A13*** - ** / *	4" BSP	1/8" + 3" 1/2 BSP - NPT - BSPT	120	130	14	14	0010R4425 - *	3

* Gasket material

** Adapter material

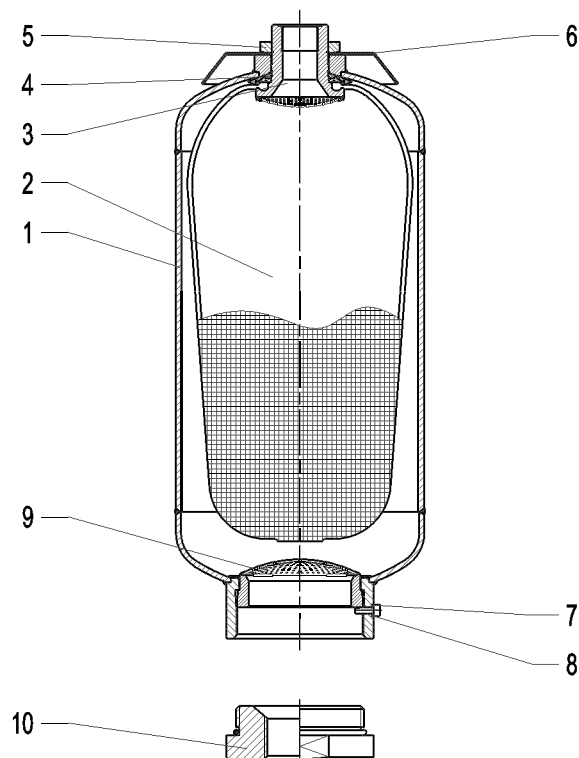
*** See chapter 3.4.8 table 7 - 8

Weigth indicated only for blind version

3.4fb

**** R Out connections type "S" and "M" thread on request

3.4.10. SPARE PARTS CODE ASBL VERSION



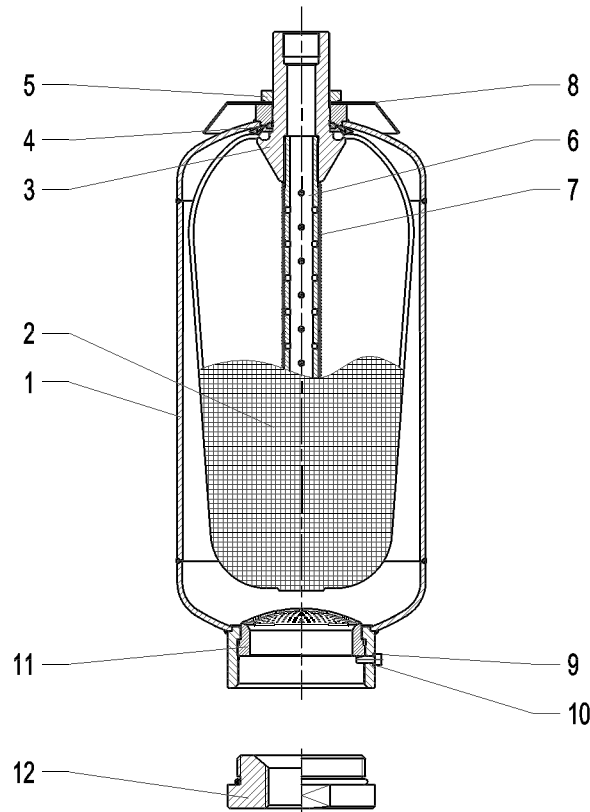
3.3ga

Item	Description	Q.ty	Type			
			ASBL 0,7	ASBL 1 - 1,5 - 3	ASBL 5	ASBL 10 + 55
1	Accumulator shell	1		Not supplied as spare part		
2	Bladder	1	S0,7* - 0	S1* - 0 / S1.5* - 0 / S3* - 0	S5* - 0	S10 + 55* - 0
3	Gas valve body	1	B10132A - **		B10229A - **	B10431A - **
4	Rubber-coated washer	1	B10104 - ** / *	B10106 - ** / *	B10205 - ** / *	B10334 - ** / *
5	Gas valve looknut	1	B10109 - **			B10302 - **
6	Name plate	1	D10300B-A		D10300C-A	D10300D-A
7	Bleed screw	1	B10316 - **			
8	Seal ring	1	B10336 - R			
9	Anti-extrusion plate	1	B11431 - **	B10159 - 1 - **	B10241 - 1 - **	B10421 - 1 - **
10	Adapter	1	See chapter 3.4.9.2 ADAPTER			
Standard gas valve ass. (parts 3 + 7)****		1	V 2027 - 1 - ** / *	V 2027 - ** / *	V 2048 - ** / *	V 2073 - ** / *
Gasket sets		1	B2449-1* $\left\{ \begin{array}{l} B10336-R \\ 0010R4175* \end{array} \right.$	B2032-1* $\left\{ \begin{array}{l} B10336-R \\ 0010R3218* \end{array} \right.$	B2052-1* $\left\{ \begin{array}{l} B10336-R \\ 0010R3281* \end{array} \right.$	B2082-1* $\left\{ \begin{array}{l} B10336-R \\ 0010R4425* \end{array} \right.$

* Gasket material ** Component material

3.3gb

ASBT VERSION



3.4gc

Item	Description	Q.ty	Type			
			ASBT 1,5	ASBT 3	ASBT 5	ASBT 10 + 55
1	Accumulator shell	1	Not supplied as spare part			
2	Bladder	1	S1,5* - 0	S3* - 0	S5* - 0	S10 + 55* - 0
3	Gas valve body	1	B10107T - **		B10219 - **	B10420 - **
4	Rubber-coated washer	1	B10106 - ** / *		B10205 - ** / *	B10334 - ** / *
5	Gas valve looknut	1	B10109 - **			B10302 - **
6	Holed pipe	1	B10141 - **	B10142 - **	B10220 - **	ASBT 10-15 = B10409 - 3 - ** ASBT 20-25 = B10409 - 4 - ** ASBT 35-55 = B10409 - 5 - **
7	Spring	1	B10218-1 - **	B10218-2 - **	B10218 - **	ASBT 10-15 = B10411-1 - ** ASBT 20-25 = B10411 - 2 - ** ASBT 35-55 = B10411 - **
8	Name plate	1	D10300B-A		D10300C-A	D10300D-A
9	Bleed screw	1	B10316 - **			
10	Seal ring	1	B10336 - R			
11	Anti-extrusion plate	1	B10159 - 1 - **		B10241 - 1 - **	B10421 - 1 - **
12	Adapter	1	See chapter 3.4.9.2 ADAPTER			
Standard gas valve ass. (parts 3 ÷ 7)		1	V 2026 - ** / *	V 2029 - ** / *	V 2043 - ** / *	AST 10-15 = V 2065 - ** / * AST 20-25 = V 2066 - ** / * AST 35-55 = V 2067 - ** / *
Gasket sets		1	B2032-1* { B10336-R 0010R3218.*		B2052-1* { B10336-R 0010R3281.*	B2082-1* { B10336-R 0010R4425.*

* Gasket material ** Component material

3.3gd

3.4.11 COMMISSIONING AND MAINTENANCE

Delivery conditions

The bladder accumulators' type ASL and AST cannot be delivered with the pre-charge.

Depending on the size and quantity ordered, the bladder are shipped in boxes, in cartons, on pallets or wooden boxes on request.

Unless otherwise required, certificates and documentation are provided together with the accumulators.

Handling

The original packaging is suitable for handling and storage.

Where necessary, you should use suitable lifting equipment to support the weight of the accumulators.

However protect from impact the packaging and handle it with care.

Storage

During storage in the warehouse, leave the product in its original packaging, keeping it away from heat sources and naked flames. The storage temperature should be between +10 and +40°C.

In addition to six months of storage, the precharge pressure must be to two bar and make sure that inside there is lubrication fluid compatible with bladder polymer.

After six years of storage, it is essential to proceed with the replacement of all elastomeric parts before the commissioning.

Marking on the nameplate of the accumulator

With reference to the PED 97/23/EC classification, Article 3, Paragraph 3 and / or risk categories I or II depending on the volume and maximum working pressure, the accumulator indicates the following data:

- Logo, name and country of the manufacturer
- Month/year of production
- Product code
- Serial number
- Maximum PS pressure and PT test pressure in bar
- Min. and max. TS working temperature in Celsius
- Volume V in litres
- Group of fluids allowed (II)
- CE marking (for volumes exceeding 1 litre) with the identification number of the notified body

It is strictly forbidden to:

- weld, rivet or screw any item of the accumulator
- engrave or permanently stamp the surfaces of the accumulator shell and / or carry out other operations that could affect or change the mechanical properties of the accumulator
- use the accumulator as a structural element: it should not be subjected to stresses or loads
- change the data of the nameplate and / or accumulator without the permission of the manufacturer
- use a (dangerous) fluid of Group 1 with equipment designed and manufactured for fluids of Group 2.

Installation

Before installation, you must perform a visual check to verify that the accumulator has not suffered any damage during shipping / handling.

Verify that the requested type matches with what stamped on the nameplate. We recommend using the accumulator with a suitable lock-off and security block type BS (see Chap. 9). This device provides the user pro-

tection and equipment against damage caused by pressure peaks and also makes easy and safe the maintenance of the accumulator, simplifying the interception and discharging. The accumulators type AS may be installed in any position from horizontal to vertical (preferably with the gas valve at the top), and the nameplate must be visible. Proceed to the assembly so that no abnormal force affects the pipes connected directly or indirectly to the accumulator, so we recommend the use of supporting components and also fastening (please see Chapter 7) to avoid the transmission of vibrations. If there are not used EPE safety blocks, make sure that the accumulator is connected to the hydraulic circuit by suitable connection devices. Make sure the fluid is compatible with the elastomer of the bladder. Check that the max. allowed accumulator pressure is equal to or greater than that of the hydraulic circuit and that the temperature during operation is maintained within the range expected. Make sure the fluid does not contain contaminants and/or abrasive.

Pre-charge of nitrogen (type AST)

The pre-charge of gas should be performed after the connection to the additional cylinders and after the installation of the accumulator in the hydraulic circuit. For the pre-charge, use only industrial dry nitrogen with a purity of min. 99%. It is important to use the nitrogen from a bottle equipped with a pressure reducing valve (see Chap.11.3). Use the EPE pre-charge and charging set type PC to check the charging pressure required, and adjust if necessary. If the pre-charge pressure is lower than required, connect the charging hose on one side and the other side connect it to the nitrogen bottle or to the pressure reducer. Slowly fill the nitrogen in the accumulator until reaching a pressure slightly higher than that set value (+10 ÷ 15%). Close the bottle and remove the charging hose from the pre-loading set; wait until the gas temperature has stabilized (2 hours) and calibrate the pressure, discharging the excess gas.

Make sure that the pre-charge valve, fittings, pipes and anything else are not subject to losses, by using, if necessary, soap and water.

Tighten the protective caps manually.

Hydraulic pressurization

- Check that the pre-charge pressure is adequate for the application
- Ensure that the hydraulic pressure never exceeds the max pressure allowed (PS) shown on the accumulator shell.

To avoid this risk, use a safety device (see Chap. 9).

Maintenance

- Periodically check the pre-charge pressure of the gas: after the commissioning, check after 2-3 weeks of operation and if there were no leaks, repeat the operation after 3 months; if the pressure at the same temperature was stable, repeat the test yearly. For heavy-duty applications, check the pre-charge every 6 months.
- Periodically (yearly) carry out a visual inspection of the accumulator in order to detect any early signs of deterioration such as corrosion, deformation, etc.
- Comply with the requirements of the regulations concerning the verification of the functionality of the equipment according to the country of installation of the accumulator.

Repair

If for failure, scheduled check or retest it is necessary to remove the accumulator from the system, prior to removal, isolate the accumulator from the installation and discharge pressure of the liquid. All bladder EPE accumulators of the ASL and AST series may be repaired.

It may consist in replacing the bladder, the seals, the pre-charge valve (AST) and/or the parts of the gas and fluid valve.
For reasons of functionality and security, it is recommended to use only original spare parts.

Disassembly

- Fasten the accumulator firmly in a vice or on a bench in a horizontal position, taking care not to damage the outer surface.



3.4m

- Remove the anti-extrusion plate



3.4h

- Remove gas valve, fastening the nut on the gas valve and remove the nameplate



3.4n

- Fold bladder somewhat and withdraw by turning it slightly



3.4i

- Unscrew the vent screw



3.4l

- Using a suitable wrench, unscrew the fluid valve (anti-extrusion plate)

Refitting

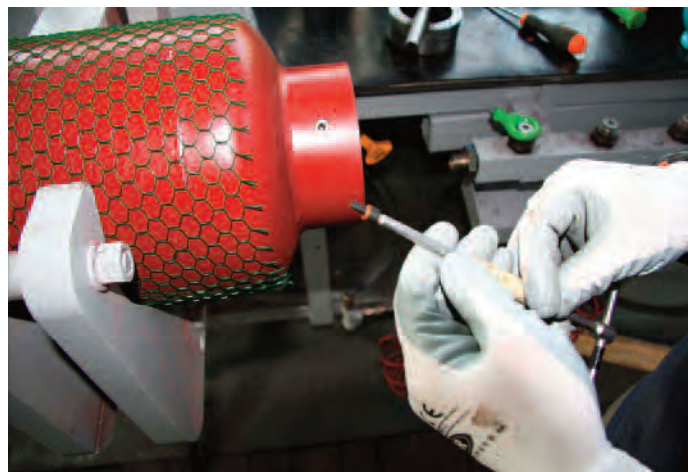
Tightening torques in Nm			
	0.7-1.5 l	3 - 5 l	10-55 l
Fluid port anti-extrusion plate	50 + 5	60 + 60	100 +10
Bleed screw	10 +2	10 +2	10 +2
Gas valve locknut	80 +20	100 +20	150 +30
Filling valve (AST)	-	-	30 +5

- Cleaning and testing : clean all metallic parts on accumulator using an organic reducer – visual inspection of valves– Clean bladder, i.e. using isopropanol. Visual inspection of bladder for faults – inner inspection of container for signs of corrosion. In event of coated containers, check the condition of the coating. Replace the parts deemed to be bad: the o-rings must always be replaced (see spare parts Section 3.4.10).



3.4o

- Drain air from bladder by pressing together



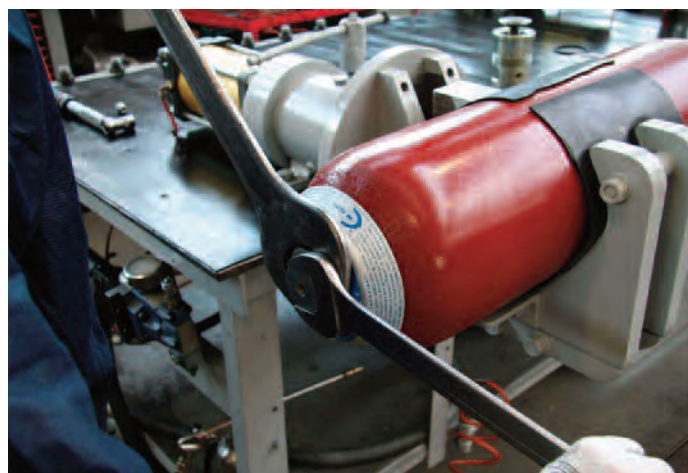
3.4r

- Bleed screw with sealing ring
- Mount the bleed screw with its sealing ring



3.4p

- Carefully moisten the inside of the bladder and the container with used medium (roll container)



3.4s

- Tighten the hexagon nut SW1 on the gas valve
- Mount the filling valve (ASBT)



3.4q

- Install the anti extrusion plate.

Pre-charge (ASBT) after having fitted the accumulator on the system and having connected it to the additional cylinders.

- Screw the pre-charge PC equipment on the gas valve.
- Connect the equipment to the cylinder of nitrogen or to the pressure reducer with the inflation tube.
- Slowly enter the nitrogen in the accumulator until reaching a pressure slightly higher than the set value (+ 10 ÷ 15%).
- Close the cylinder and remove the connecting pipe from the equipment.
- Wait until the gas temperature has stabilized (2 hours).
- Calibrate the pressure discharging the excess gas.

Make sure that the gas valve, the fittings and the pipes are not subject to losses and, if necessary, use soap and water. Tighten the protective caps manually.

Demolition and recycling of the accumulator

Before accumulator demolition or recycling, you should always discharge completely the pre-charge pressure and remove the gas valve (ASBT). If you need, proceed decontaminating in relation to the fluid used prior to demolition.

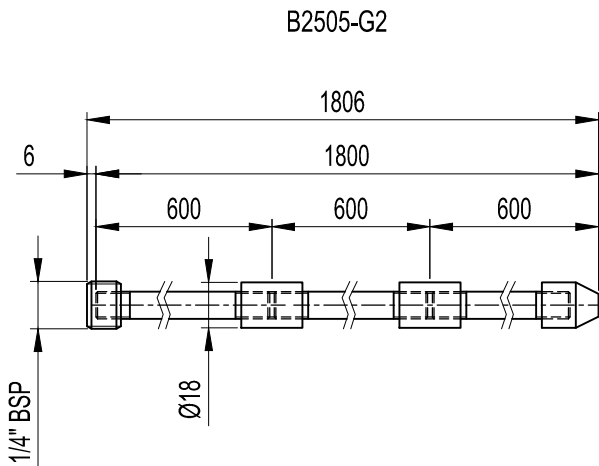
3.4.12 REPAIR TOOLS

3.4.12.1 BLADDER PULL ROD

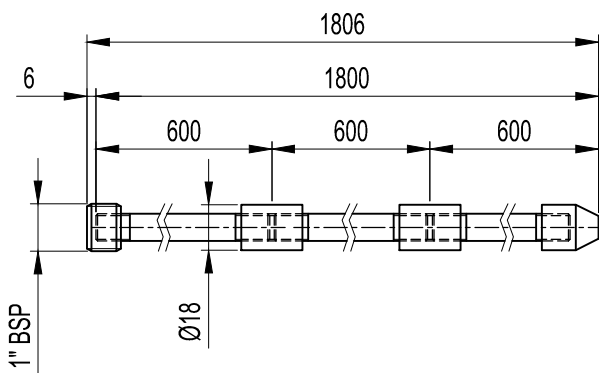
The pull rod screwed to the gas valve of the bladder for easy assembly into shell during reassembly. Pull rod is complete with fitting for EPE gas valve and 3 extension segments to accommodate all size of accumulators.

Code for complete kit: B2505-G2 / B2505-G6

Dimension



B2505-G6



3.4aa

3.4.12.2 LIFTING HOOK

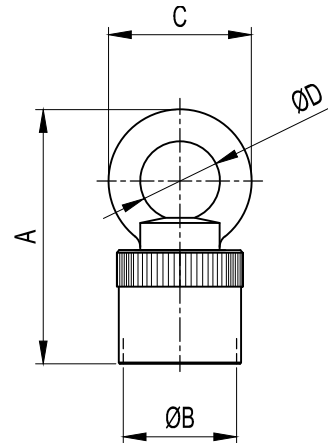
To be used for the safe lifting of mounted accumulators:

For accumulators 0,7÷5 It (M22x1,5) code B2507/2

For accumulators 10÷55 It (M50x1,5) code B2507/5

For accumulators V4 (7/8" UNF) code B2507/7

Dimension



CODE	A	ØB	C	ØD	For Accumulator
B2507/2	100	M22x1.5	63	35	0.7 ÷ 1.5
B2507/5	112	M50x1.5	63	35	3 ÷ 5
B2507/7	100	7/8" UNF	63	35	10 ÷ 55

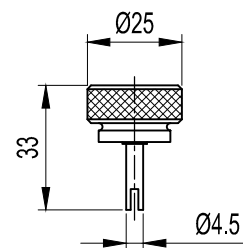
3.4ab

3.4.12.3 CORE TOOL

The core tool is used to remove and reinstall the valve core type V4.

Code B2508

Dimension



3.4ac

Reproduction is forbidden.

In the spirit of continuous improvement, our products may be changed.

3.5.1 TECHNICAL DATA

MAX OPERATING PRESSURE (PS): 4000 PSI

PRESSURE TEST (PT): 1.5 x PS

NOMINAL CAPACITIES: 1/4 - 1 - 2.5 - 5 - 10 - 15 gallons

WORKING TEMPERATURE: -40 ÷ +200 °F (-40 ÷ +93 °C)

COMPRESSION RATIO (Po : P2): max. 1 : 4

FLUID VISCOSITY RANGE: 10 ÷ 400 cSt

RECOMMENDED VISCOSITY: 36 cSt

FLUID CONTAMINATION DEGREE:
class 21/19/16 according to ISO 4406/99

BODY MATERIAL:

- carbon steel shell (SA 372 grade E class 70)
 painted with rust inhibitor RAL 8012
- nickel coating 25 - 40 µ
- internal and external coating with RILSAN th. 0.6 mm

VALVES MATERIAL:

- phosphated or galvanized carbon steel in compliance
 with Directive 2002/95/EC (RoHS) to resist to corrosion
- stainless steel AISI 316L
- nickel coating 25-40 µ

BLADDER MATERIAL:

- P = Nitrile rubber (NBR)
- F = Low temp. nitrile rubber
- H = Nitrile for hydrocarbons
- K = Hydrogenated nitrile (HNBR)
- B = Butyl (IIR)
- E = Ethylene-propylene (EPDM)
- N = Chloroprene (Neoprene)
- Y = Epichlorohydrin (ECO)
- V = Fluorocarbon (FPM)

See Table 3.5c and/or Chapter 1.5

FILLING VALVE CONNECTION:

- 5/8"-UNF std
- 7/8" UNF
- 1/4" BSP

FLUID PORT CONNECTION: see Table 3.5dc - 3.5df - 3.5eb - 3.5ec

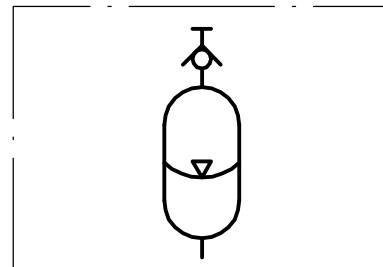
FLOW RATE: see Table 3.5db

WEIGHT: see Table 3.5db - 3.5df



3.5a

3.5.2 HYDRAULIC SYMBOL



3.5b

3.5.3 “ASA” BLADDER ADVANTAGES

- dirt tolerant
- light weight
- compact
- simple construction
- quick response
- works well on water, low lubricity fluids
- quick, easy installation
- low cost

3.5.4 DESCRIPTION

ASA Bladder-type accumulators consist of a seamless cylindrical pressure vessel made of high-tensile steel.

The accumulator is subdivided into a gas and fluid side by an elastic bladder mounted in the interior of the vessel.

The bladder is charged with nitrogen to the specified gas charge pressure P_0 by means of gas valve.

When the fluid is pressed into the accumulator, the gas in the bladder is compressed and hence the pressure increased. The gas volume reduces and on the fluid side, the fluid can flow into the accumulator. As soon as the pressure on the fluid side falls below the gas pressure, the accumulator is emptied.

Oil valve is provided in the oil port of the bladder-type accumulator and closes when the pressure on the gas side is higher than the one on the fluid side. This prevents draining of the bladder into the oil channel and thus the bladder from being destroyed.

When the minimum operating pressure is reached, a small oil volume is to be maintained between the bladder and the fluid volume (approx. 10% of the nominal capacity of the hydraulic accumulator), in order that the bladder does not hit the valve during every expansion process.

Gas valve consists of external caps, sealing cap, filling valve, gas valve body and rubber coated washer. These parts can be replaced separately.

The nameplate shows the technical data and features of the hydraulic accumulator.

3.5.5 ACCESSORIES

For support equipment, see Cap. 7

For gas side's safety equipment, see Cap. 8

For fluid side's safety equipment, see Cap. 9

For pre-loading and charging set, see Cap. 11

For other components, see Cap. 12

3.5.6 BLADDER-TEMPERATURE-LIQUID COMPATIBILITY

When selecting the accumulator variant, pay attention to the following non-binding notes with regard to hydraulic fluid, bladder material and the permissible temperature range. (see Section 1.5)

Code letter	Polymer	ISO	Temperature range (°C)	Some of the liquids compatible with the polymer
P	Standard nitrile (Perburan)	NBR	-20 ÷ +80	Aliphatic hydrocarbons (propane, butane, gasoline, oils, mineral greases, diesel fuel, fuel oil, kerosene), mineral greases and oils, HFA - HFB - HFC fluids, many dilute acids, alkalis, saline solutions, water, water glycol.
F	Low temperature nitrile	NBR	-40 ÷ +70	The same as with standard nitrile + a number of different types of Freon. (This contains less acrylonitrile than the standard and is therefore more suitable for low temperatures, but its chemical resistance is slightly lower).
H	Nitrile for hydrocarbons	NBR	-10 ÷ +90	Regular and premium grade slightly aromatic gasoline (and all the liquids for standard nitrile).
K	Hydrogenated nitrile	HNBR	-30 ÷ +130	The same as with standard nitrile but with excellent performance at high and low temperatures.
B	Butyl	IIR	-30 ÷ +100	Hot water up to 100°C, glycol-based brake fluids, many acids and bases, salt solutions, polar solvents such as alcohols, ketones and esters, polyglycol-based hydraulic fluids (HFC fluids) and bases of esters of phosphoric acid (HFD-R fluids), silicone oils and greases, Skydol 500 and 7000, resistance to ozone, aging and weathering.
E	Ethylene-Propylene	EPDM	-30 ÷ +100	Hot water up to 100°C, glycol-based brake fluids, many organic and inorganic acids, detergents, solutions of sodium and potassium, phosphate ester-based hydraulic fluids, (HFD-R), silicone oils and greases, many polar solvents (alcohol, ketones, esters), Skydol 500 and 7000, resistance to ozone, aging and weathering.
N	Chloroprene (Neoprene)	CR	-30 ÷ +100	Mineral oils of paraffin, silicone oils and greases, water and aqueous solutions, refrigerants (ammonia, carbon dioxide, Freon), naphthenic mineral oils, low molecular aliphatic hydrocarbons (propane, butane, fuel), brake fluids based on glycol, better resistance to ozone, weathering and aging compared to NBR rubber.
Y	Epichloridrin	ECO	-30 ÷ +110	Mineral oils and greases, aliphatic hydrocarbons (propane, butane and gasoline), silicone oils and greases, water at room temperature, resistance to ozone, aging and weathering.
V	Fluorocarbon	FPM	-10 ÷ +150	Mineral oils and greases, non-flammable fluids of HFD group, silicone oils and greases, animal and vegetable oils and greases, aliphatic hydrocarbons (gasoline, butane, propane, natural gas), aromatics hydrocarbons (benzene, toluene), chlorinated hydrocarbons (Tetrachloroethylene, carbon tetrachloride), fuel (regular, super and containing methanol), excellent resistance to ozone, weathering and aging.

For other hydraulic fluid and/or temperatures, please consult us.

3.5c

3.5.7 ORDER CODE

1	2	3	4	5	6	7-8	9	10	11	12	13	14	15	16	
ASA	15	P	4000	C	R	P5	V4	-	7	-	C	0	C	0	R250 / 435

1	Series
Bladder accumulator with ASME U-STAMP = ASA	

2	Nominal capacity (gallons)
1/4 gal (0.95 lt) = 1/4	
1 gal (3.78 lt) = 1	
2.5 gal (9.46 lt) = 2.5	
5 gal (18.93 lt) = 5	
10 gal (37.85 lt) = 10	
15 gal (56.78 lt) = 15	

3	Bladder material
Nitrile rubber (NBR) = P	
Nitrile for low temp. = F	
Nitril for hydrocarbons = H	
Hydrogenated nitrile (HNBR) = K	
Butyl (IIR) = B	
Ethylene-propylene (EPDM) = E	
Chloroprene (Neoprene) = N	
Epichlorohydrin (ECO) = Y	
Fluorocarbon (FPM) = V	

4	Max working pressure (PS)
4000 PSI (275 bar) = 4000	
(3000 only for the version with connection L or other pressure related to connections B or U)	

5	Body material
Carbon steel = C	
Nickel coated carbon steel 25 μ = N	
Nickel coated carbon steel 40 μ = M	
Stainless steel = X	
Rilsan coating = V	

6	Fluid port connection
See the table on front page	

7-8	Dimension of the connection fluid or 7+8 table
See the table on front page	

16	Precharge pressure (bar)
Standard 435 PSI = 0 ÷ 3600 PSI (30 bar)	

15	Other variants
See the table on front page	

14	Variants of gas side
Standard = 0	
Only cap in stainless steel = 1	
Brass nameplate = 2	
Other numbers/variants to be requested EPE	

13	Gas valve material
Carbon steel = C	
Nickel coated carbon steel 25 μ = N	
Nickel coated carbon steel 40 μ = M	
Stainless steel = X	

12	Variants of fluid side
Standard = 0	
Adapter in stainless steel (R) = 1	
Button and spring in stainless steel = 2	
Other numbers/variants to be requested EPE	

11	Fluid valve material
Carbon steel = C	
Nickel coated carbon steel 25 μ = N	
Nickel coated carbon steel 40 μ = M	
Stainless steel = X	

10	Testing and certification
ASME U-STAMP (ASME VIII div.1 appendix 22) = 7	

9	Connection gas side
Standard filling valve 5/8" UNF thread = V	
Standard filling valve with 5/8" UNF thread in stainless steel = VX	
Without filling valve (thread hole M12x1.5) = V0	
Brass filling valve 1/4" BSP = V2	
Filling valve 7/8" UNF = V4	

Special variants upon request

6	Fluid port connection
	For ASA 1/4÷15 gallons BSP ISO 228 with chamfer for OR (std) = A
	For ASA 1÷15 gallons Metric = M
	For ASA 1/4÷15 gallons NPT-F = P
	For ASA 1÷15 gallons internal thread SAE = S
	For ASA 1÷15 gallons adapter for flange SAE 3000 Psi = L
	For ASA 1÷15 gallons adapter for flange SAE 6000 Psi = H
	For ASA 1/4÷15 gallons flange ANSI = B
	For ASA 1/4÷15 gallons flange UNI = B
	For ASA 1/4÷15 gallons square flange = Q
	For ASA 1/4÷15 gallons adapter * = R
	* assembled on the fluid valve connection type A

15	Other variants
	Adapter + Burst disc set at xxx bar = Rxxx (see Section 8.2)
	Adapter + Safety valve, type VS224TX set at xxx bar = Gxxx
	Adapter + Needle Valve of 1/4" BSP = EG2
	Adapter + Stainless steel needle Valve of 1/4" BSP = EG2X
	Adapter + Excluding device with with full scale pressure gauge of xxx bar = EMxxx
	Adapter + Excluding device of 90° with full scale pressure gauge of xxx bar = ELMxxx
	Flushing with degree of contamination ≤ x = Fx
	75-80 μ thick. polyurethane paint with colour to be specified = Wxxx
	Off-shore paint with colour to be specified = Zxxx
	NORSOK System 1 paint with colour to be specified = K1
	NORSOK System 7 paint with colour to be specified = K7
	other variants upon request

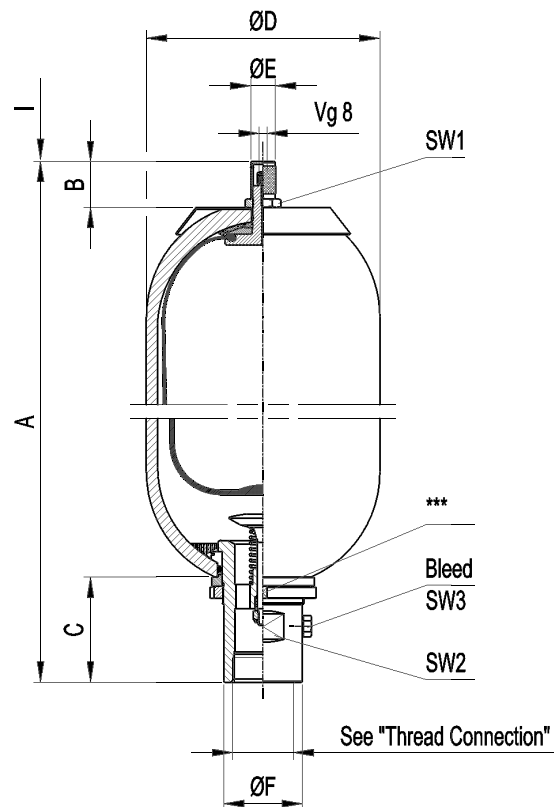
7	Dimension of the fluid connection
	For the type of connection:
	A (1/4 gallon) 1" 1/4 = 7 (2.5 ÷15 gallons) 2" = 9
	M (1/4 gallon) 40x1.5 = 40/1.5 (2.5 ÷15 gallons) 50x1.5 = 50/1.5
	P (1/4 gallon) 1" 1/4 = 7 (2.5 ÷15 gallons) 2" = 9
	S (1/4 gallon) 1" 5/8 12UN = 1 5/8-12 (2.5 ÷15 gallons) 1" 7/8 12UN = 1 7/8-12
	L (1/4 gallon) 1" 1/4 SAE3000 = 7 (Pmax = 3000) (2.5 ÷15 gallons) 1" 1/2 SAE 3000 = 8 (Pmax = 3000) 2" SAE 3000 = 9
	H (1/4 gallon) 1" 1/4 SAE6000 = 7 (2,5 ÷15 gallons) 1" 1/2 SAE 6000 = 8 2" SAE 6000 = 9
	B = DIMENSION/RATING Former. 1" ANSI 600 = 1/600 (Pmax =600)
	U = DN/PN Former. DN50 PN100 = 50/1450 (Pmax =1450)
	Q (1/4 gallon) 1" 1/4 = 7 (2.5 ÷15 gallons) 2" = 9
	R Blind = 0 R internal thread = G* BSP ISO 228 = P* NPT-F = P* BSPT = N*
	SAE = S* Metric = M*
	*Variant in table 8

8	Dimension		
1/8"	= 1	3/4"	= 5
1/4"	= 2	1"	= 6
3/8"	= 3	1" 1/4"	= 7
1/2"	= 4	1" 1/2"	= 8

Dimension in inch - No.of pitch for inch
Diameter/pitch

Special variants upon request

3.5.9 DIMENSIONS



3.5da

Acc. type ASA in carbon steel	Nominal gas volume gallons	Effective gas volume litres	Working pressure bar	Max.diff. pressure P2-P1 psi	Flow rate l/min	Max.comp. ratio P0/P2	A mm	B mm	C mm	Ø D mm	Ø E mm	Ø F mm	I mm	SW 1 mm	SW 2 mm	SW 3 mm	Bleed	Acc. dry weight kg
ASA 1/4	1/4	1	4000	1450	300	1:4	272 ± 5	26	52	114	20	36	140	24	32	4*	M5	5.2
ASA 1	1	3,5	4000	1450	600	1:4	391 ± 10	47	65	168	25	53	140	32	50	4*	M5	13
ASA 2,5	2,5	9,1	4000	1450	1000	1:4	544 ± 10	47	101	229	25	77	140	32	70	19**	1/4" BSP	37
ASA 5	5	18,2	4000	1450	1000	1:4	848 ± 10	47	101	229	25	77	140	32	70	19**	1/4" BSP	58
ASA 10	10	33,5	4000	1450	1000	1:4	1382 ± 10	47	101	229	25	77	140	32	70	19**	1/4" BSP	96
ASA 15	15	50	4000	1450	1000	1:4	1903 ± 10	47	101	229	25	77	140	32	70	19**	1/4" BSP	133

* Allen wrench

** Ex. wrench

*** see chapter 3.5.12.2 table 3.5ab

3.5db

* The maximum differential pressure is the maximum allowable difference between the maximum pressure and the minimum working pressure (P2-P1) to have an infinite life cycle of the accumulator (greater than 2,000,000 cycles).

** Flow rate measured using mineral oil with viscosity of 36 cSt at 50°C and $\Delta P = 5$ bar

3.5.9.1 STANDARD THREAD CONNECTIONS

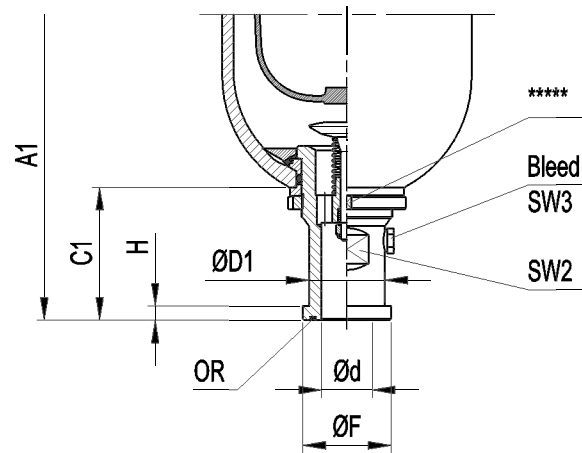
Dimensions	Connection Type	Accumulator type	Complete spare valve order code	Ød	ØD mm	ØF mm	H mm
	A BSP ISO 228 with chamfer for OR	ASA 0,2	-	-	-	-	-
		ASA 0,7	V 2023-A5-**/*	3/4" BSP	28,8	36	19
		ASA 1	V 2024-A5-**/*				
		ASA 1,5					
		ASA 3	V 2025-A7-**/*	1" 1/4 BSP	46	53	25
		ASA 5	V 2044-A7-**/*				
		ASA 10 ÷ 55	V 2064-A9- **/*	2" BSP	63,35	77	28
	G BSP ISO 228	ASA 0,2	V 2004-G4-**/*	1/2" BSP	-	26	15
		ASA 0,7	-	-	-	-	-
		ASA 1	-	-	-	-	-
		ASA 1,5	-	-	-	-	-
		ASA 3	-	-	-	-	-
		ASA 5	-	-	-	-	-
		ASA 10 ÷ 55	-	-	-	-	-
	M Metric	ASA 0,2	-	-	-	-	
		ASA 0,7					
		ASA 1					
		ASA 1,5	V 2025-M40x1.5-**/*	M40x1,5	-	53	25
		ASA 3					
		ASA 5	V 2044-M40/1.5-**/*				
		ASA 10 ÷ 55	V 2064-M50/1.5-**/*	M50x1,5	-	77	28
	P NPT-F	ASA 0,2	-	-	-	-	
		ASA 0,7	V 2023-P5-**/*	3/4" NPT-F	-	36	Thread plug gage
		ASA 1	V 2024-P5-**/*				
		ASA 1,5					
		ASA 3	V 2025-P7-**/*	1" 1/4 NPT-F	-	53	
		ASA 5	V 2044-P7-**/*				
		ASA 10 ÷ 55	V 2064-A9- **/*	2" NPT-F	-	77	
	S SAE thread	ASA 0,2	-	-	-	-	
		ASA 0,7	V 2023-S1 /16-12-**/*	1" 1/16 12 UN	29,16	36	19
		ASA 1	V 2024-S1 /16-12-**/*				
		ASA 1,5					
		ASA 3	V 2025-S1 5/8-12-**/*	1" 5/8 12 UN	43,5	53	23
		ASA 5	V 2044-S1 5/8-12-**/*				
		ASA 10 ÷ 55	V 2064-S1 7/8-12-**/*	1" 7/8 12 UN	49,84	77	26

* Gasket material

** Component material

3.5dc

3.5.9.2 ADAPTER FOR FLANGE SAE 3000/6000 PSI (L/H)



3.5de

Acc. type ASA in carbon steel	Dim.	A1 mm	C1 mm	SW2 mm	SW3 mm	Bleed	Ød mm	SAE 3000 (L)				SAE6000 (H)				OR (Included)	Acc. dry weight kg
								Spare valve order code	ØD1 mm	ØF mm	H mm	Spare valve order code	ØD1 mm	ØF mm	H mm		
ASA 1/4	-	-	-	-	-	-	-	-	-	-	-	-	-	-	-	-	-
ASA 1	1"	493 ± 10	100	38	4****	M5	31	V 2044-L7-***	43	50,8	8	V 2044-H6-***	38	47,6	9,5	0010R4131-*	13
	1 1/4"	482 ± 10	89	38	4****	M5	31	V 2044-L7-***	43	50,8	8	V 2044-H7-***	44	53,3	10,3	0010R4150-*	
ASA 2.5	1 1/2"	583 ± 10	115	42	19****	1/4"	32	V 2064-L8-***	50	60,3	8	V 2064-H8-***	51	63,5	12,5	0010R4187-*	37
	2"			55	BSP	45	V 2064-L9-***	62	71,5	9,5	V 2064-H9-***	67	77,6	0010R4225-*			
ASA 5	1 1/2"	733 ± 10	115	42	19****	1/4"	32	V 2064-L8-***	50	60,3	8	V 2064-H8-***	51	63,5	12,5	0010R4187-*	58
	2"			55	BSP	45	V 2064-L9-***	62	71,5	9,5	V 2064-H9-***	67	77,6	0010R4225-*			
ASA 10	1 1/2"	893 ± 10	115	42	19****	1/4"	32	V 2064-L8-***	50	60,3	8	V 2064-H8-***	51	63,5	12,5	0010R4187-*	96
	2"			55	BSP	45	V 2064-L9-***	62	71,5	9,5	V 2064-H9-***	67	77,6	0010R4225-*			
ASA 15	1 1/2"	1058 ± 15	115	42	19****	1/4"	32	V 2064-L8-***	50	60,3	8	V 2064-H8-***	51	63,5	12,5	0010R4187-*	133
	2"			55	BSP	45	V 2064-L9-***	62	71,5	9,5	V 2064-H9-***	67	77,6	0010R4225-*			

* Gasket material

** Component material

*** Allen wrench

**** Ex. Wrench

***** see chapter 3.5.12.2 table 3.5ab

3.5df

3.5.9.3 FLANGE CONNECTION TYPE ANSI / UNI DIN (B/U)

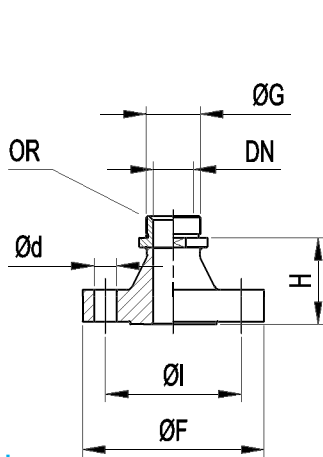


Fig. I

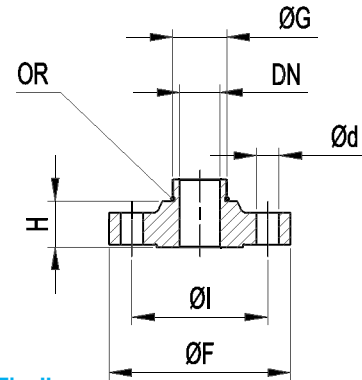
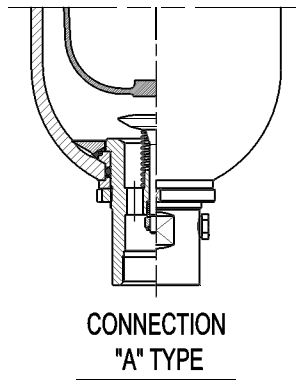


Fig. II

3.5ea

	Accumulator type	Spare flange order code	Ref. Directive		DN mm	PN bar	Fig.	Ø F mm	Ø I mm	Ø d mm	N° Holes	H mm	G BSP	OR (Included)
			UNI	DIN										
U (UNI-DIN)	ASA 1/4	F 2205 - ** / *	2284	2635	20	40	II	105	75	14	4	23	3/4"	0010R2093-*
		F 2206 - ** / *	6086	2628		250		135	95	18	4	45		
	ASA 1	F 2211 - ** / *	2284	2635	25	40	I	115	85	14	4	51	1 1/4"	0010R3150-*
		F 2212 - ** / *	6086	2628		250		150	105	22	4	76		
		F 2215 - ** / *	2284	2635	32	40	II	140	100	18	4	22		
		F 2216 - ** / *	6086	2628		250		165	120	22	4	55		
	ASA 2.5 + 15	F 2221 - ** / *	2282	2633	25	16	I	115	85	14	4	49	2"	0010R3218-*
		F 2222 - ** / *	2284	2635		40		115	85	14	4	51		
		F 2223 - ** / *	6086	2628		250		150	105	22	4	76		
		F 2227 - ** / *	2284	2635	40	40	I	150	110	18	4	56		
		F 2228 - ** / *	6086	2628		250		185	135	25	4	91		
		F 2231 - ** / *	2282	2633	50	16	II	165	125	18	4	23		
		F 2232 - ** / *	2285	2636		64		185	135	22	4	40		
		F 2233 - ** / *	6086	2628		250		200	150	25	8	61		

* Gasket material

** Flange material

Others size on request

3.5eb

	Accumulator type	Spare flange order code	Ref. Directive	DN inch	PN lbs	Fig.	Ø F mm	Ø I mm	Ø d mm	N° Holes	H mm	G BSP	OR (Included)
F 2208 - ** / *	B16.5	1500	130	88,9	22,5	4	59						
ASA 1	F 2213 - ** / *	B16.5	1"	300	I	123,5	88,9	22,5	4	73	1 1/4"	0010R3150-*	
	F 2214 - ** / *	B16.5		1500		149,5	101,6	25,4	4	90			
	F 2217 - ** / *	B16.5	1 1/4"	300	II	133,3	98,4	19	4	44			
	F 2218 - ** / *	B16.5		1500		159	111,1	25,4	4	58			
ASA 2.5 + 15	F 2225 - ** / *	B16.5	1"	300	I	123,5	88,9	19	4	73	2"	0010R3218-*	
	F 2226 - ** / *	B16.5		1500		149,5	101,6	25,4	4	90			
	F 2229 - ** / *	B16.5	1 1/2"	300	I	155,6	114,3	22,2	4	79			
	F 2230 - ** / *	B16.5		1500		178	123,8	28,5	4	100			
	F 2235 - ** / *	B16.5	2"	400	II	165	127	19	8	55			
	F 2236 - ** / *	B16.5		1500		216	165,1	25,4	8	83			

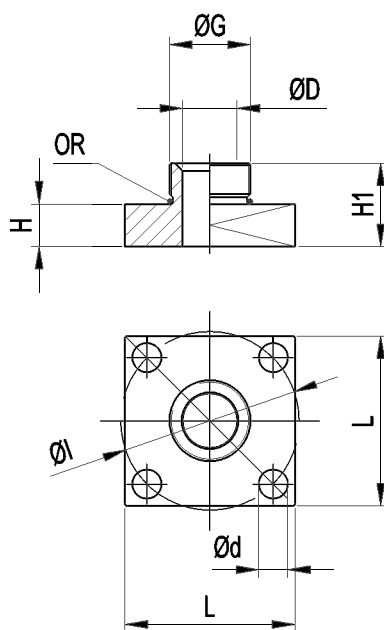
* Gasket material

** Flange material

Others size on request

3.5ec

3.5.9.4 SQUARE FLANGE CONNECTION



3.5fa

Accumulator type	Spare square flange order code	α G BSP	Ø D mm	L mm	Ø l mm	H mm	Ø d mm	H 1 mm	Weight Kg	OR (Included)
ASA 3 - 5	F 2454 A7 - ** / *	1" 1/4 BSP	26	100	105	25	17.5	49	0,8	0010R3150 - *
ASA 10 ÷ 55	F 2455 A9 - ** / *	2" BSP	32						0,9	0010R3218 - *

* Gasket material

** Square flange material

Weight indicated only for blind version

3.5fb

3.5.9.5 ADAPTERS

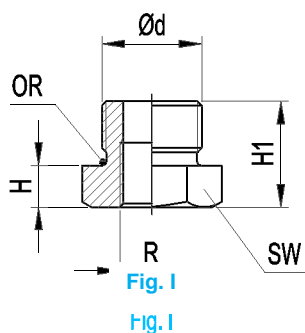


Fig. I
Fig. I

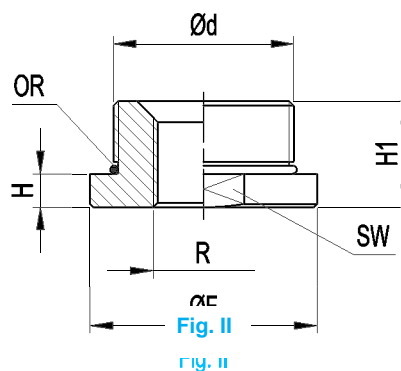


Fig. II
Fig. II

3.5fc

Accumulator type	Order code	Ød Acc. connection	R**** Out connections (0 = blind)	Fig.	SW mm	Ø F mm	H mm	H1 mm	OR (Included)	Weight Kg
ASA 0,7 - 1 - 1,5	R - A5*** - ** / *	3/4" BSP	1/8" + 3/8" BSP - NPT - BSPT	I	32	-	11	28	0010R2093 - *	0,14
			1/2" BSP - NPT - BSPT	I			28	45		0,27
ASA 3 - 5	R - A7*** - ** / *	1" 1/4 BSP	1/8" + 1" BSP - NPT - BSPT	II	48	53	11	32	0010R3150 - *	0,41
ASA 10 ÷ 55	R - A9*** - ** / *	2" BSP	1/8" + 1" 1/2 BSP - NPT - BSPT	II	70	75	11	35	0010R3218 - *	0,86

* Gasket material

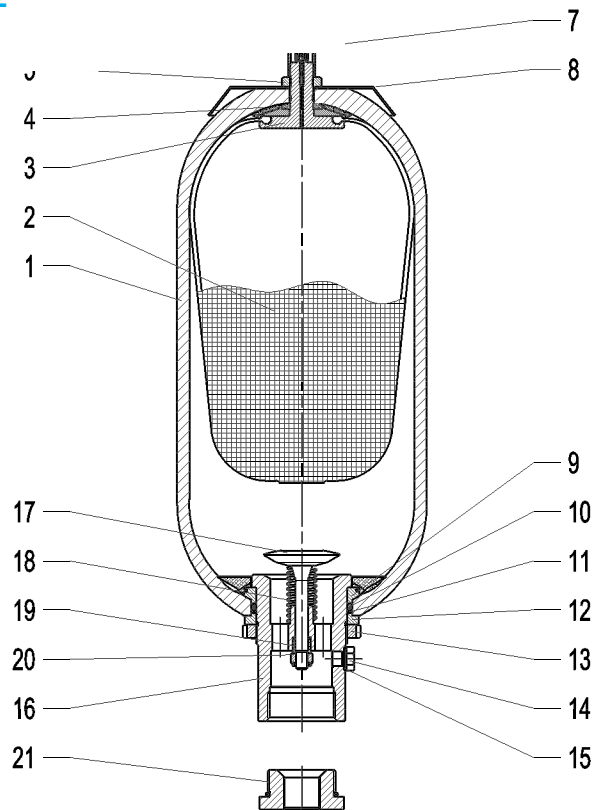
** Adapter material

*** See chapter 3.5.7 table 7 - 8

Weight indicated only for blind version

3.5fd

3.5.10. SPARE PARTS CODE



3.5ga

Item	Description	Q.ty	Type		
			ASA 1/4	ASA 1	ASA 2.5 ÷ 15
1	Accumulator shell	1	Not supplied as spare part		
2	Bladder	1	S1* - 0	S5* - 0	S10 ÷ 55* - 0
3	Gas valve body	1	B10110 - **	B10259 - **	B10330 - **
4	Rubber-coated washer	1	B10106 - ** / *	B10205 - ** / *	B10331 - ** / *
5	Gas valve looknut	1	B10023 - **	B10108 - **	
6	Protection cap	1	B10337/00 - ** / *	B10135 - **	
7	Valve mechanism	1	V 2070 - ** / *	V 2069 - ** / *	
8	Name plate	1	D10300B-A	D10300C-A	D10300D-A
9	Retaining ring	1	B10127 - ** / *	B10222 - ** / *	B10317 - ** / *
10	"O" ring	1	0010R4150 - *	0010R6212 - *	0010R0181 - *
11	Supporting ring	1	B10133-T	B10227-T	B10320-T
12	Space ring	1	B10120 - **	B10223 - **	B10319 - **
13	Fluid port ring nut	1	B10122 - **	B10217 - **	B10321 - **
14	Bleed screw	1	B10128 - **		B10316A - **
15	Seal ring	1	B10129-R		0010T14-1/4 - *
16	Fluid port body std. version	1	B10115 - *** - **	B10144 - *** - **	B10311 - *** - **
17	Poppet	1	B10111 - **	B10221 - **	B10310 - **
18	Spring	1	B10112 - **	B10149 - **	B10322 - **
19	Brake bushing	1	B10113 - **	B10226 - **	B10314 - **
20	Selflocking nut	1	B10116 - **	B10211 - **	B10315 - **
21	Adapter	1	See chapter 3.5.9.5 ADAPTER		
Standard gas valve ass. (parts 3 ÷ 7)		1	V 2020 - ** / *	V 2046 - ** / *	V 2085 - ** / *
Standard fluid port ass. (parts 9 ÷ 20)		1	V 2024 - *** - ** / *	V 2044 - *** - ** / *	V 2064 - *** - ** / *
Gasket sets		1	B2380* { 0010R2015* 0010R4150* B10133-T B10129-R 0010R2083* }	B2381* { 0010R2015* 0010R6212* B10227-T B10129-R 0010R3150* }	B2382* { 0010R2015* 0010R0181* B10320-T 0010T14-1/4* 0010R3218* }

* Gasket material ** Component material *** See chapter 3.5.8 table 6 - 7

3.5gb

3.5.11 COMMISSIONING AND MAINTENANCE

Delivery condition

Bladder accumulators type ASA are delivered pre-charged with nitrogen at a pressure of 435 PSI or at value of pressure required at time of order. The pre-charge value is still on the nameplate of the accumulator.

Depending on the size and quantity ordered, the diaphragm accumulators are shipped in boxes or in cartons or on pallets, or wooden boxes on request. Unless otherwise required, certificates and documentation are provided together with the accumulators.

Handling

The original packaging is suitable for handling and general storage. Where necessary, you should use suitable lifting equipment to support the weight of the accumulators.

Protect from impact, however, the packaging and handle it with care.

Storage

During storage in the warehouse, leave the product in its original packaging, keeping it away from heat sources and naked flames. The storage temperature should be between +10 and +40°C.

In addition to six months of storage, the precharge pressure must be to two bar and make sure that inside there is lubrication fluid compatible with bladder polymer.

After six years of storage, it is essential to proceed with the replacement of all elastomeric parts before the commissioning.

Marking on the nameplate of the accumulator

The accumulator will be supplied with the following data stamped on the nameplate:

- Logo, name and country of the manufacturer
- Month/year of production
- Product code
- Serial number
- Maximum PS pressure and PT test pressure in Psi
- Min. and max. TS working temperature in Fahrenheit
- Volume V in gallons
- ASME U-stamp
- Pre-charge pressure in Psi

It is strictly forbidden to:

- weld, rivet or screw any item of the accumulator
- engrave or permanently stamp the surfaces of the accumulator shell and / or carry out other operations that could affect or change the mechanical properties of the accumulator
- use the accumulator as a structural element: it should not be subjected to stresses or loads
- change the data of the nameplate and / or accumulator without the permission of the manufacturer
- use a (dangerous) fluid of Group 1 with equipment designed and manufactured for fluids of Group 2.

Installation

Before installation, you must perform a visual check to verify that the accumulator has not suffered any damage during shipping / handling.

Verify that the requested type matches with what stamped on the nameplate. We recommend using the accumulator with a suitable security valve (see Chapter 8) or a security lock-off BS type (see Chapter 9).

This device provides user and equipment protection against possible damage caused by pressure surges, and also makes the maintenance of the accumulator easier, so facilitating the interception and the discharge. Provide for a clearance of 200 mm above the gas pre-charge valve to allow access to and control of the pre-charge equipment (see Chap.11.1). The accumulators type ASA may be installed in any position from horizontal to vertical (preferably with the pre-charge valve at the top), and the nameplate must be visible. Proceed to the assembly so that no abnormal force affects the pipes connected directly or indirectly to the accumulator, so we recommend the use of supporting components and also fastening (please see Chapter 7) to avoid the transmission of vibrations. If there are not used safety EPE blocks, make sure that the accumulator is connected to the hydraulic circuit by suitable connection devices. Make sure the fluid is compatible with the elastomer of the bladder. Check that the max. allowed accumulator pressure is equal to or greater than that of the hydraulic circuit and that the temperature during operation is maintained within the range expected.

Make sure the fluid does not contain contaminants and/or abrasive.

Pre-charge of nitrogen

Normally, the bladder accumulators are delivered pre-charged with pressurized gas. The pre-charge of gas can be controlled and / or adjusted before or after installation of the accumulator in the hydraulic circuit.

For the pre-charge, use only industrial dry nitrogen with a purity of min. 99%. It is important to use the nitrogen from a cylinder equipped with a pressure reducing valve (see Chap.11.3).

Use the EPE pre-charge and charging set type PC to check the charging pressure Calculated Against the pressure, and adjust if necessary. If the pre-charge pressure is lower than required, connect the inflation tube on one side and the other of the equipment.

Connect it to the cylinder of nitrogen or to the pressure reducer. Slowly enter the nitrogen in the accumulator until reaching a pressure slightly higher than that set (+ 10 ÷ 15%).

Close the cylinder and remove the connecting pipe from the equipment; wait until the gas temperature has stabilized (2 hours) and calibrate the pressure, discharging the excess gas.

Make sure that the gas valve is not subject to losses and, if necessary, use soap and water.

Tighten the protective caps manually.

Hydraulic pressurization

- Check that the pre-charge pressure is adequate for the application
- Ensure that the hydraulic pressure never exceeds the max. (PS) allowed and shown on the accumulator shell.

To avoid this risk, use a safety item (see Chap. 9).

Maintenance

- Periodically check the pre-charge pressure of the gas: after the commissioning, check after 2-3 weeks of operation and if there were no leaks, repeat the operation after 3 months; if the pressure at the same temperature was stable, repeat the test at annual intervals.

For heavy-duty applications, check the pre-charge every 6 months.

- Periodically (annually) carry out a visual inspection of the accumulator in order to detect any early signs of deterioration such as corrosion, deformation, etc.

- Comply with the requirements of the regulations concerning the verification of the functionality of the equipment according to the country of installation of the accumulator.

Repair

If for failure, scheduled check or retest it is necessary to remove the accumulator from the system, prior to removal, isolate the accumulator from the installation and discharge pressure of the liquid.

All bladder EPE accumulators of the AS and ASP series may be repaired. It may consist in replacing the bladder, the seals, the pre-charge valve and/or the parts of the gas and fluid valve.

For reasons of functionality and security, it is recommended to use only original spare parts.

Disassembly

- Fasten the accumulator firmly in a vice or on a bench in a horizontal position, taking care not to damage the outer surface.
- If you have not already carried out, unscrew the cap nut first and then the valve cap of the gas valve.
- Allow gas escapes from the bladder with the help of the check valve until a pressure of 0 is displayed. Check if the bladder is now de-pressurizing an open valve.
- Remove gas valve, fastening the nut on the gas valve and remove the nameplate
- Unscrew the vent screw
- Using a suitable wrench, unscrew the fluid valve (anti-extrusion plate)
- Push enough oil valve into the housing until the sealing ring and the washer can be removed.
- Remove the sealing ring and the washer
- Remove the retaining ring; take it out, by carefully pushing the ring together.
- Remove the oil valve from the container
- Fold bladder somewhat and withdraw by turning it slightly

Refitting

Tightening torques in Nm		
	1/4 gallon	2.5÷15 gallons
Fluid port ring nut	200 +50	450 +50
Bleed screw	5 +1	30 +10
Gas valve locknut	100 +20	150 +30
Filling valve V - VX - V2	30 +5	30 +5
Valve insert V4	0.3 +0.2	0.3 +0.2

3.5gd

- Cleaning and testing: clean all metallic parts on accumulator using an organic reducer – visual inspection of oil valve parts (valve tappet, spring, nut, damping screw) – check valve for sluggishness – Clean bladder, i.e. using isopropanol. Visual inspection of bladder for faults – inner inspection of container for signs of corrosion. In event of coated containers, check the condition of the coating. Replace the parts deemed to be bad; the o-rings must always be replaced (see spare parts Section 3.5.8).

- Drain air from bladder by pressing together
- Carefully moisten the inside of the bladder and the container with used medium (roll container)
- Reinstall according to this sequence: o-ring, washer and spacer sleeve.
- Screw the slotted nut and centre the parts on the oil valve by using a plastic hammer
- Bleed screw with sealing ring
- Mount the bleed screw with its sealing ring
- Tighten the hexagon nut SW1 on the gas valve
- Mount the filling valve with tightening torques, see Table 3.5gd.

Pre-charge

- Screw the pre-charge PC equipment on the gas valve.
- Connect the equipment to the cylinder of nitrogen or to the pressure reducer with the inflation tube.
- Slowly enter the nitrogen in the accumulator until reaching a pressure slightly higher than the set value (+ 10 ÷ 15%).
- Close the cylinder and remove the connecting pipe from the equipment.
- Wait until the gas temperature has stabilized (2 hours).
- Calibrate the pressure discharging the excess gas.
- Make sure that the gas valve is not subject to losses and, if necessary, use soap and water.
- Tighten the protective caps manually.

Demolition and recycling of the accumulator

Before accumulator demolition or recycling, you should always discharge completely the pre-charge pressure and remove the gas valve. If needed, proceed decontaminating in relation to the fluid used prior to demolition.

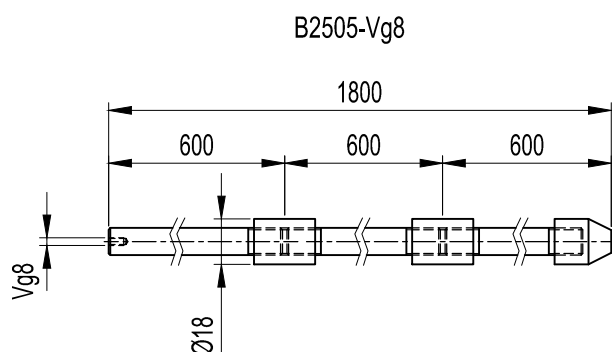
3.5.12 REPAIR TOOLS

3.5.12.1 BLADDER PULL ROD

The pull rod screwed to the gas valve of the bladder for easy assembly into shell during reassembly. Pull rod is complete with fitting for EPE gas valve and 3 extension segments to accommodate all size of accumulators.

Code for complete kit: B2505-Vg8

Dimension



3.5.12.2 SPANNER WRENCH

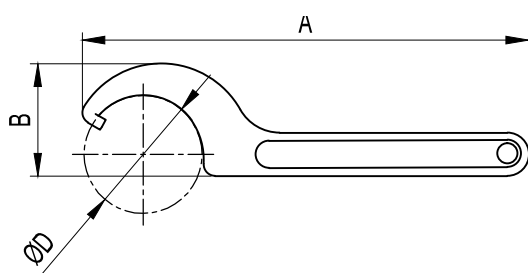
Fits all standard size bladder accumulator. It is used to remove or install lock nut on fluid port assembly.

0,7÷1,5 gal code 2506/58

3÷5 gal code 2506/68

10÷55 gal code 2506/105

Dimension



CODE	A	B	ØD	For Accumulator
B2506/58	241	45	58	1/4 gal
B2506/68	241	43	68	1 gal
B2506/105	336	82	105	2.5 ÷ 15 gal

3.5ab

3.5.12.3 LIFTING HOOK

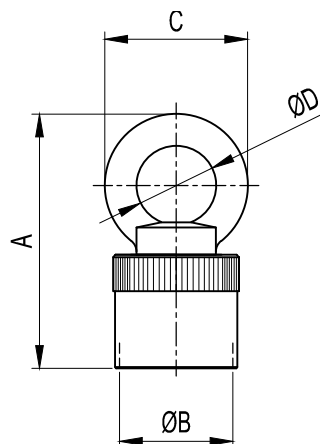
To be used for the safe lifting of mounted accumulators:

For accumulators 0,7÷5 lt (M22x1,5) code B2507/2

For accumulators 10÷55 lt (M50x1,5) code B2507/5

For accumulators V4 (7/8" UNF) code B2507/7

Dimension



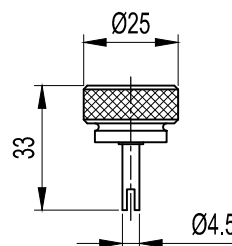
CODE	A	ØB	C	ØD	For Accumulator
B2507/2	100	M22x1.5	63	35	1/4 gal
B2507/5	112	M50x1.5	63	35	1 gal
B2507/7	100	7/8" UNF	63	35	2.5 ÷ 15 gal

3.5.12.4 CORE TOOL

The core tool is used to remove and reinstall the valve core type V4.

Code B2508

Dimension



3.5ad

Reproduction is forbidden.

In the spirit of continuous improvement, our products may be changed.

3.6.1 TECHNICAL DATA

MAX OPERATING PRESSURE (PS): 16 bar

PRESSURE TEST (PT): 1.43 x PS

NOMINAL CAPACITIES: 100 - 150 - 200 - 300 - 500 - 750 - 1000 - 1500
- 2000 - 3000 - 4000 - 5000 litres

WORKING TEMPERATURE: -30 ÷ +100 °C

COMPRESSION RATIO (Po : P2): max. 1 : 4

FLUID VISCOSITY RANGE: 10 ÷ 400 cSt

RECOMMENDED VISCOSITY: 36 cSt

FLUID CONTAMINATION DEGREE:
class 21/19/16 according to ISO 4406/99

BODY MATERIAL:

- carbon steel shell painted with rust inhibitor RAL 5015 up to 1500 lt;
- RAL 9010 for capacities from 2000 lt to 5000 lt
- stainless steel AISI 316L

VALVES MATERIAL:

- phosphated or galvanized carbon steel in compliance with Directive 2002/95/EC (RoHS) to resist to corrosion
- stainless steel AISI 316L

BLADDER MATERIAL:

- P = Nitrile rubber (NBR)
- B = Butyl (IIR)
- E = Ethylene-propylene (EPDM)

See Table 3.6c and/or Chapter 1.5

FILLING VALVE CONNECTION:

- 5/8"-UNF std
- 7/8" UNF
- 1/4" BSP

FLUID PORT CONNECTION: see Table 3.6e

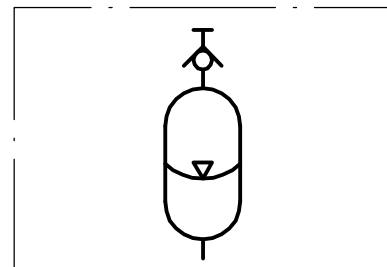
FLOW RATE: see Table 3.6e

WEIGHT: see Table 3.6e



3.6a

3.6.2 HYDRAULIC SYMBOL



3.6b

3.6.3 “ASE” BLADDER ADVANTAGES

- dirt tolerant
- light weight
- compact
- simple construction
- quick response
- works well on water, low lubricity fluids
- quick, easy installation
- low cost

3.6.4 DESCRIPTION

ASE Bladder-type accumulators consist of a cylindrical pressure vessel made of high-tensile steel.

The accumulator is subdivided into a gas and fluid side by an elastic bladder mounted in the interior of the vessel.

The nitrogen is charged to the specified gas charge pressure P_0 by means of gas valve at the external of the bladder.

When the fluid is pressed into the bladder, the gas in the accumulator is compressed and hence the pressure increased. The gas volume reduces and on the fluid side, the fluid can flow into the bladder. As soon as the pressure on the fluid side falls below the gas pressure, the accumulator is emptied.

A special oil valve (anti-extrusion plate) is provided in the oil port in order to prevent draining of the bladder into the oil channel and thus the bladder from being destroyed.

When the minimum operating pressure is reached, a small oil volume is to be maintained between the bladder and the fluid volume (approx. 10% of the nominal capacity of the hydraulic accumulator), in order that the bladder does not hit the valve during every expansion process.

Gas valve consists of a sealing cap, a filling valve and an adapter.

The nameplate shows the technical data and features of the hydraulic accumulator.

3.6.5 EUROPE MARKET

All hydraulic accumulators are pressure vessels and are subject to the national regulations and directives, valid at the place of installation.

Every shipping batch is complete of a conformity declaration and instruction of use and maintenance and/or all documents requested.

All vessel categories (see Table 3.6e) must be protected by means of a pressure relief valve in accordance with Directive 97/23/EC.

3.6.6 ACCESSORIES

For gas side's safety equipment, see Cap. 8

For fluid side's safety equipment, see Cap. 9

For pre-loading and charging set, see Cap. 11

For other components, see Cap. 12

3.6.7 BLADDER-TEMPERATURE-LIQUID COMPATIBILITY

When selecting the accumulator variant, pay attention to the following non-binding notes with regard to hydraulic fluid, bladder material and the permissive temperature range. (see Section 1.5)

Code letter	Polymer	ISO	Temperature range (°C)	Some of the liquids compatible with the polymer
P	Standard nitrile (Perburan)	NBR	-20 ÷ +80	Aliphatic hydrocarbons (propane, butane, gasoline, oils, mineral greases, diesel fuel, fuel oil, kerosene), mineral greases and oils, HFA - HFB - HFC fluids, many dilute acids, alkalis, saline solutions, water, water glycol.
B	Butyl	IIR	-30 ÷ +100	Hot water up to 100°C, glycol-based brake fluids, many acids and bases, salt solutions, polar solvents such as alcohols, ketones and esters, polyglycol-based hydraulic fluids (HFC fluids) and bases of esters of phosphoric acid (HFD-R fluids), silicone oils and greases, Skydol 500 and 7000, resistance to ozone, aging and weathering.
E	Ethylene-Propylene	EPDM	-30 ÷ +100	Hot water up to 100°C, glycol-based brake fluids, many organic and inorganic acids, detergents, solutions of sodium and potassium, phosphate ester-based hydraulic fluids, (HFD-R), silicone oils and greases, many polar solvents (alcohol, ketones, esters), Skydol 500 and 7000, resistance to ozone, aging and weathering.

For other hydraulic fluid and/or temperatures, please consult us.

3.6c

3.6.8 ORDER CODE

1	2	3	4	5	6	7	8	9	10	11	12	13	14	15			
ASE	500	P	16	C	B	4/150	V	-	8	-	C	0	C	0	ELM25	/	1,5

1	Series
Bladder accumulator	= ASE

2	Nominal capacity
100 lt =	100
150 lt =	150
200 lt =	200
300 lt =	300
500 lt =	500
750 lt =	750
1000 lt =	1000
1500 lt =	1500
2000 lt =	2000
3000 lt =	3000
4000 lt =	4000
5000 lt =	5000

3	Bladder material
Nitrile rubber (NBR)	= P
Butyl (IIR)	= B
Ethylene-propylene (EPDM)	= E

4	Max working pressure (PS)
See the table on front page	

5	Body material
Carbon steel	= C
Stainless steel	= X

6	Fluid port connection
Flange ANSI	= B
Flange UNI	= U

7	Dimension of the connection fluid
For the type of connection:	
B	= DIMENSION/RATING
Former. 4" ANSI 150 = 4/150	
U	= DN/PN
Former. DN100 PN10 = 100/10	
Special variants upon request	

Special variants upon request

15	Precharge pressure (bar)
Standard 1.5 bar = 0 ÷ 6 (< PS)	

14	Other variants
See the table on front page	

13	Variants of gas side
Standard	= 0
Other numbers/variants to be requested EPE	

12	Gas valve material
Carbon steel	= C
Stainless steel	= X

11	Variants of fluid side
Standard	= 0
Other numbers/variants to be requested EPE	

10	Fluid valve material
Carbon steel	= C
Stainless steel	= X

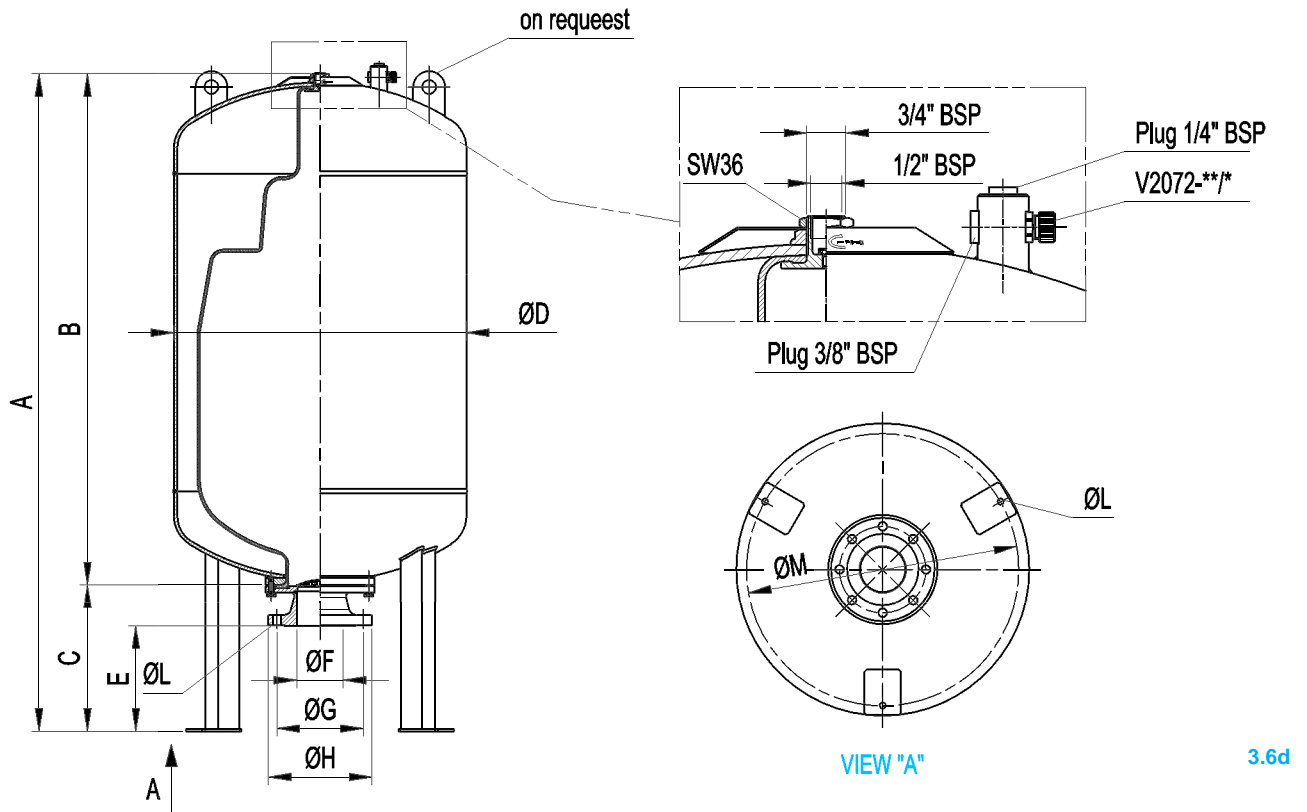
9	Testing and certification
Factory testing	= 0
PED 97/23/EC	= 8
ATEX 94/9EC	= 9

8	Type of filling valve
Standard filling valve 5/8" UNF thread	= V
Standard filling valve with 5/8" UNF thread in stainless steel	= VX
Without filling valve (thread hole M12x1.5)	= V0
Brass filling valve 1/4" BSP	= V2
Filling valve 7/8" UNF	= V4

4 Max working pressure (PS)		
Capacity litres	Carbon steel	Stainless steel
100 ÷ 500	750 ÷ 5000	10 -16
750 ÷ 5000	10	10

14 Other variants
Dumper + Safety valve, type VS2470-11 set at 11 bar = F11
Dumper + Needle Valve of 1/4" BSP = EG2
Dumper + Stainless steel needle Valve of 1/4" BSP = EG2X
Dumper + excluding device with with full scale pressure gauge of xxx bar (see Section...) = EMxxx
Dumper + excluding device of 90° with full scale pressure gauge of xxx bar = ELMxxx
Flushing with degree of contamination ≤ x = Fx
75-80 μ thick polyurethane paint with colour to be specified = Wxxx
Off-shore paint with colour to be specified = Zxxx
NORSOK System 1 paint with colour to be specified = K1
NORSOK System 7 paint with colour to be specified = K7
other variants upon request

3.6.9 DIMENSIONS



Acc. type ASE in carbon steel and stainless steel	Nominal gas volume liters	Working pressure bar	Ped category liquids of group 2	Max.diff. pressure P2-P1 bar	Flow rate l/min	Max.comp. ratio P0/P2	A ± 10 mm	B mm	C mm	Ø D ± 10 mm	E mm	Ø F mm	Ø G mm	Ø H mm	Ø L mm	N° fixing holes	Ø M mm	Acc. dry weight kg
ASE 100	100	10 + 16	II + III	4	300	1:4	880	560	320	460	232	102,4	190,5	233	19	8	-	18
ASE 150	150	10 + 16	III	4	300	1:4	1030	710	320	510	232	102,4	190,5	233	19	8	-	22
ASE 200	200	10 + 16	III + IV	4	300	1:4	1100	780	320	590	232	102,4	190,5	233	19	8	440	35
ASE 300	300	10 + 16	III + IV	4	300	1:4	1280	960	320	650	232	102,4	190,5	233	19	8	440	45
ASE 500	500	10 + 16	III + IV	4	300	1:4	1600	1280	320	750	232	102,4	190,5	233	19	8	550	60
ASE 750	750	10	IV	4	300	1:4	1850	1530	320	800	232	102,4	190,5	233	19	8	-	75
ASE 1000	1000	10	IV	4	300	1:4	2130	1810	320	800	232	102,4	190,5	233	19	8	-	85
ASE 1500	1500	10	IV	4	300	1:4	2130	1810	320	1000	232	102,4	190,5	233	19	8	-	105
ASE 2000	2000	10	IV	4	300	1:4	2550	2550	320	1100	232	102,4	190,5	233	19	8	-	140
ASE 3000	3000	10	IV	4	300	1:4	2930	2610	320	1250	232	102,4	190,5	233	19	8	-	205
ASE 4000	4000	10	IV	4	300	1:4	3030	2710	320	1450	232	102,4	190,5	233	19	8	-	250
ASE 5000	5000	10	IV	4	300	1:4	3800	3480	320	1450	232	102,4	190,5	233	19	8	-	310

3.6e

* The maximum differential pressure is the maximum allowable difference between the maximum pressure and the minimum working pressure (P2-P1) to have an infinite life cycle of the accumulator (greater than 2,000,000 cycles).

** Flow rate measured using mineral oil with viscosity of 36 cSt at 50°C and ΔP = 5 bar

3.6.10 SPARE PARTS CODE

Item	Description	Q.ty	Type					
			ASE 100	ASE 150	ASE 200	ASE 300	ASE 500	ASE 750
1	Bladder	1	S100*** - 0	S150*** - 0	S200*** - 0	S300*** - 0	S500*** - 0	S750*** - 0
2	Gas-fill valve	1	V 2072 - ** / *					
Item	Description	Q.ty	Type					
			ASE 1000	ASE 1500	ASE 2000	ASE 3000	ASE 4000	ASE 5000
1	Bladder	1	S1000*** - 0	S1500*** - 0	S2000*** - 0	S3000*** - 0	S4000*** - 0	S5000*** - 0
2	Gas-fill valve	1	V 2072 - ** / *					

* Gasket material ** Component material *** Bladder material

3.6f

03.6.11 COMMISSIONING AND MAINTENANCE

Delivery conditions

Bladder accumulators are delivered pre-charged with nitrogen at a pressure of 1.5 bar or at value of pressure required at time of order. The pre-charge value is also on the nameplate of the accumulator. The bladder accumulators type ASE are shipped in cartons on pallets or, upon request, in wooden crates. Unless otherwise required, certificates and documentation are provided together with the accumulators.

Handling

The original packaging is suitable for handling and general storage. Where necessary, you should use suitable lifting equipment to support the weight of the accumulators.

However protect from impact the packaging and handle it with care.

Storage

During storage in the warehouse, leave the product in its original packaging, keeping it away from heat sources and naked flames. The storage temperature should be between +10 and +40°C.

After six years of storage, it is essential to proceed with the replacement of all elastomeric parts before the commissioning.

Marking on the nameplate of the accumulator

With reference to the PED 97/23/EC classification, Article 3, Paragraph 3 and / or risk categories I or II depending on the volume and maximum working pressure, the accumulator indicates the following data:

- Logo, name and country of the manufacturer
- Month/year of production
- Product code
- Serial number
- Maximum PS pressure and PT test pressure in bar
- Min. and max. TS working temperature in Celsius
- Volume V in litres
- Group of fluids allowed
- CE marking (for volumes exceeding 1 litre) with the identification number of the notified body
- Pre-charge pressure in bar

It is strictly forbidden to:

- weld, rivet or screw any item of the accumulator
- engrave or permanently stamp the surfaces of the accumulator shell and / or carry out other operations that could affect or change the mechanical properties of the accumulator
- use the accumulator as a structural element: it should not be subjected to stresses or loads
- change the data of the nameplate and / or accumulator without the permission of the manufacturer

- use a (dangerous) fluid of Group 1 with equipment designed and manufactured for fluids of Group 2.

Installation

Before installation, you must perform a visual check to verify that the accumulator has not suffered any damage during shipping / handling.

Verify that the requested type matches with what stamped on the nameplate. We recommend using the accumulator with a suitable security valve (see Chapter 8) or a security block type BS (see Chapter 9).

This device provides user and equipment protection against possible damage caused by pressure surges and also makes the maintenance of the accumulator easier, facilitating the interception and the discharge. Provide for a space of 200 mm above the gas pre-charge valve to allow access to and control of the pre-charge equipment (see Chap.11.1).

The accumulators type ASE may be installed with the pre-charge valve at the top, and the nameplate must be visible. Proceed to the assembly so that no abnormal force affects the pipes connected directly or indirectly to the accumulator. Make sure the fluid is compatible with the elastomer of the bladder. Check that the max. allowed accumulator pressure is equal to or greater than that of the hydraulic circuit and that the temperature during operation is maintained within the range expected.

Make sure the fluid does not contain contaminants and/or abrasive.

Pre-charge of nitrogen

Normally, the bladder accumulators are delivered pre-charged with pressurized gas. The pre-charge of gas can be controlled and / or adjusted before or after installation of the accumulator in the hydraulic circuit.

For the pre-charge, use only industrial dry nitrogen with a purity of min. 99%. It is important to use the nitrogen from a bottle equipped with a pressure reducing valve (see Chap.11.3). Use the EPE pre-charge and charging set type PC to check the charging pressure required, and adjust if necessary. If the pre-charge pressure is lower than required, connect the charging hose on one side and the other side connect it to the nitrogen bottle or to the pressure reducer. Slowly fill the nitrogen in the accumulator until reaching a pressure slightly higher than that set value (+ 10 ÷ 15%). Close the bottle and remove the charging hose from the pre-loading set; wait until the gas temperature has stabilized (2 hours) and calibrate the pressure, discharging the excess gas. Make sure that the gas valve is not subject to losses and, if necessary, use soap and water.

Tighten the protective caps manually.

Hydraulic pressurization

- Check that the pre-charge pressure is adequate for the application
- Ensure that the hydraulic pressure never exceeds the max pressure allowed (PS) shown on the accumulator shell.

To avoid this risk, use a safety device (see Chap. 9).

Maintenance

- Periodically check the pre-charge pressure of the gas: after the commissioning, check after 2-3 weeks of operation and if there were no leaks, repeat the operation after 3 months; if the pressure at the same temperature was stable, repeat the test yearly.
For heavy-duty applications, check the pre-charge every 6 months.
- Periodically (yearly) carry out a visual inspection of the accumulator in order to detect any early signs of deterioration such as corrosion, deformation, etc.
- Comply with the requirements of the regulations concerning the verification of the functionality of the equipment according to the country of installation of the accumulator.

Repair

If for failure, scheduled check or retest it is necessary to remove the accumulator from the system, prior to removal, isolate the accumulator from the installation and discharge pressure of the liquid. It may consist in replacing the bladder, the seals, the pre-charge valve and/or the parts of the gas and fluid valve. For reasons of functionality and security, it is recommended to use only original spare parts.

Demolition and recycling of the accumulator

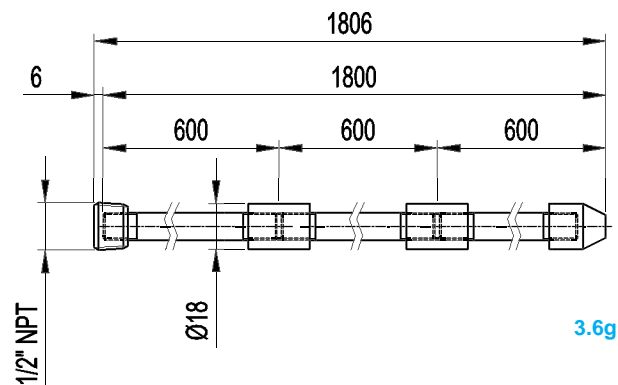
Before accumulator demolition or recycling, you should always discharge completely the pre-charge pressure and remove the gas valve. If needed, proceed decontaminating in relation to the fluid used prior to demolition.

3.6.12 REPAIR TOOLS

3.6.12.1 BLADDER PULL ROD

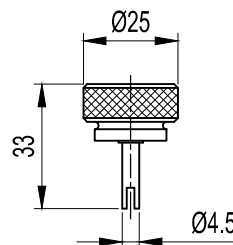
The pull rod screwed for the gas valve of the bladder for easy assembly into shell during rassembly. Pull rod is complete with fitting for EPE gas valve and 3 extension segments to accommodate all size of accumulators. Code for complete kit: B2505-P4.

Dimension



3.6.12.2 CORE TOOL

The core tool is used to remove and reinstall the valve core type V4. Code B2508



Reproduction is forbidden.

In the spirit of continuous improvement, our products may be changed.

3.7.1 TECHNICAL DATA

THE BLADDER, used in the standard version of the accumulators of all the series offered by EPE, is made in butadiene-acrylonitrile rubber (NBR) with medium-high ACN content which we have denoted "standard nitrile" and distinguished with the letter P. The "P" bladder is suitable for use with mineral oils but gives also excellent results with many other liquids. The operating temperature range is between -20 and $+80^{\circ}\text{C}$. For special requirements, temperatures exceeding the above limits, special liquids, etc. the bladder can be supplied in the following materials: Nitrile for low temperatures (F), Nitrile for hydrocarbons (H), Hydrogenated Nitrile (K), Butyl (B), Ethylene-propylene (E), Neoprene (N), Epichlorohydrin (Y), Viton (V). See section 1,5.

N.B. Not all the sizes of bladders are available in all the materials.

Please consult our Technical Service Department before ordering of gas valve assembly.

The two parts, bladder and gas valve assembly, can be ordered separately so when is necessary the replacement of the bladder, it is possible to use again the gas valve assembly saving in this way money on the purchasing price of the spare bladder.

THE GAS VALVE used in the EPE accumulators is made of phosphated carbon steel, in the following three versions:

S = STANDARD. For capacities from 0,2 to 55 litres with inflating valve 5/8" UNF.

This valve can be supplied with \varnothing B and special inflation connections.

ST = TRANSFER. Suitable for use with the accumulator connected to one or more additional nitrogen bottles. For capacities from 5 to 55 litres.

SL = LIQUID SEPARATOR. It is used when a liquid is also inside the bladder. For capacities from 0,2 to 55 litres.

UPON REQUEST, all the valves can be supplied with chemical nickel coating $25\ \mu\text{m}$ or $40\ \mu\text{m}$. (other thickness to be specified) or in stainless steel.



3.7a

3.7.2 DESCRIPTION

The EPE bladder is made by two different and separable parts. One is the rubber bladder of which the main feature lies in an original and well developed process that allows the construction in a single piece. The second part is the gas valve assembly that is seal connected on the bladder mechanically. This unique method allows to seal connect on the same bladder different types.

3.7.3 SPECIAL GAS VALVE: NON EPOll ACCUMULATORS

EPE bladders, in addition to their use in EPE accumulators, are perfectly interchangeable with many others brands available in the market. In order to do that, gas valves (see below) are available with nonstandard stem diameters (\varnothing B) and charge-connections.

3.7.4 BLADDER-TEMPERATURE-LIQUID COMPATIBILITY

When selecting the accumulator variant, pay attention to the following non-binding notes with regard to hydraulic fluid, bladder material and the permissible temperature range. (see Section 1.5)

Code letter	Polymer	ISO	Temperature range (°C)	Some of the liquids compatible with the polymer
P	Standard nitrile (Perburan)	NBR	-20 ÷ +80	Aliphatic hydrocarbons (propane, butane, gasoline, oils, mineral greases, diesel fuel, fuel oil, kerosene), mineral greases and oils, HFA - HFB - HFC fluids, many dilute acids, alkalis, saline solutions, water, water glycol.
F	Low temperature nitrile	NBR	-40 ÷ +70	The same as with standard nitrile + a number of different types of Freon. (This contains less acrylonitrile than the standard and is therefore more suitable for low temperatures, but its chemical resistance is slightly lower).
H	Nitrile for hydrocarbons	NBR	-10 ÷ +90	Regular and premium grade slightly aromatic gasoline (and all the liquids for standard nitrile).
K	Hydrogenated nitrile	HNBR	-30 ÷ +130	The same as with standard nitrile but with excellent performance at high and low temperatures.
B	Butyl	IIR	-30 ÷ +100	Hot water up to 100°C, glycol-based brake fluids, many acids and bases, salt solutions, polar solvents such as alcohols, ketones and esters, polyglycol-based hydraulic fluids (HFC fluids) and bases of esters of phosphoric acid (HFD-R fluids), silicone oils and greases, Skydol 500 and 7000, resistance to ozone, aging and weathering.
E	Ethylene-Propylene	EPDM	-30 ÷ +100	Hot water up to 100°C, glycol-based brake fluids, many organic and inorganic acids, detergents, solutions of sodium and potassium, phosphate ester-based hydraulic fluids, (HFD-R), silicone oils and greases, many polar solvents (alcohol, ketones, esters), Skydol 500 and 7000, resistance to ozone, aging and weathering.
N	Chloroprene (Neoprene)	CR	-30 ÷ +100	Mineral oils of paraffin, silicone oils and greases, water and aqueous solutions, refrigerants (ammonia, carbon dioxide, Freon), naphthenic mineral oils, low molecular aliphatic hydrocarbons (propane, butane, fuel), brake fluids based on glycol, better resistance to ozone, weathering and aging compared to NBR rubber.
Y	Epichloridrin	ECO	-30 ÷ +110	Mineral oils and greases, aliphatic hydrocarbons (propane, butane and gasoline), silicone oils and greases, water at room temperature, resistance to ozone, aging and weathering.
V	Fluorocarbon	FPM	-10 ÷ +150	Mineral oils and greases, non-flammable fluids of HFD group, silicone oils and greases, animal and vegetable oils and greases, aliphatic hydrocarbons (gasoline, butane, propane, natural gas), aromatics hydrocarbons (benzene, toluene), chlorinated hydrocarbons (Tetrachloroethylene, carbon tetrachloride), fuel (regular, super and containing methanol), excellent resistance to ozone, weathering and aging.

For other hydraulic fluid and/or temperatures, please consult us.

3.1c

3.7.5 ORDER CODE

1	2	3	4	5	6
S	25	P	-	C	50
					V

1 Series	
Standard	= S
Transfer	= ST
Liquid separator	= SL

2 Nominal capacity	
0.2 lt =	0.2
0.7 lt =	0.7
1 lt =	1
1.5 lt =	1.5
2.5 lt =	2.5
3 lt =	3
4 lt =	4
5 lt =	5
10 lt =	10
12 lt =	12
15 lt =	15
20 lt =	20
25 lt =	25
35 lt =	35
55 lt =	55
for ASE range	
100 -:- 5000	

3 Bladder material	
Nitrile rubber (NBR)	= P
Nitrile for low temp.	= F
Nitril for hydrocarbons	= H
Hydrogenated nitrile (HNBR)	= K
Butyl (IIR)	= B
Ethylene-propylene (EPDM)	= E
Chloroprene (Neoprene)	= N
Epichlorohydrin (ECO)	= Y
Fluorocarbon (FPM)	= V

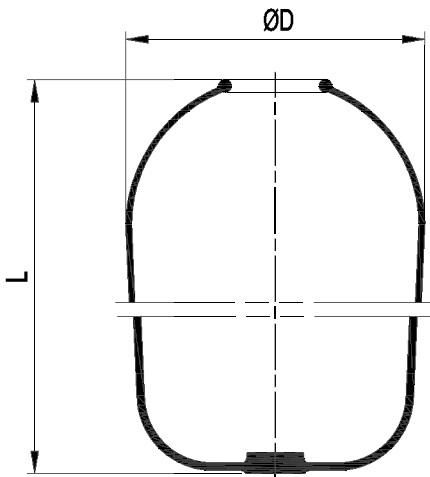
6 Type of filling valve*	
Standard filling valve 5/8" UNF thread =	V
Standard filling valve with 5/8" UNF thread in stainless steel =	VX
Without filling valve (thread hole M12x1.5) =	V0
Brass filling valve 1/4" BSP =	V2
Filling valve 7/8" UNF =	V4
For ASE Type =	-

* Only for S and ST series

5 Gas valve dimension	
M50X1.5 =	50
M22X1.5 =	22
7/8" UNF =	7/8
5/8" UNF =	5/8
For ASE 3/4 BSP =	3/4

4 Gas valve material	
Whitout valve =	0
Carbon steel =	C
Nickel coated carbon steel 25 μ =	N
Nickel coated carbon steel 40 μ =	M
Stainless steel =	X

3.7.6 BLADDER DIMENSIONS AND SPARE PARTS CODES



3.7c

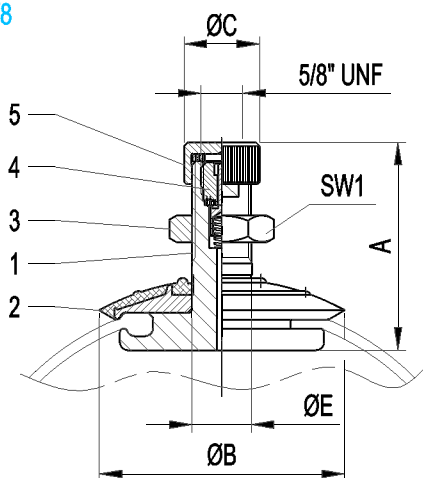
Bladder type S	Nominal gas volume litres	ØD mm	L mm	Bladder order code	Wheight Kg
S 0,2	0,2	38,5	148 ± 1,5	S 0,2* - 0	0,031
S 0,7	0,7	74	120 ± 2	S 0,7* - 0	0,060
S 1	1	95	140 ± 2	S 1* - 0	0,130
S 1,5	1,5	95	192 ± 2	S 1,5* - 0	0,165
S 2,5	2,5	95	320 ± 2	S 2,5* - 0	0,295
S 3	3	95	365 ± 2	S 3* - 0	0,348
S 4	4	144	201 ± 2	S 4* - 0	0,394
S 5	5	144	275 ± 2	S 5* - 0	0,415
S 10	10	198	305 ± 3	S 10* - 0	0,92
S 12	12	198	393 ± 3	S 12* - 0	1,09
S 15	15	198	440 ± 4	S 15* - 0	1,30
S 20	20	198	580 ± 5	S 20* - 0	1,73
S 25	25	198	725 ± 5	S 25* - 0	2,15
S 35	35	198	1105 ± 5	S 35* - 0	3,3
S 55	55	198	1550 ± 5	S 55* - 0	4,6

* Bladder material

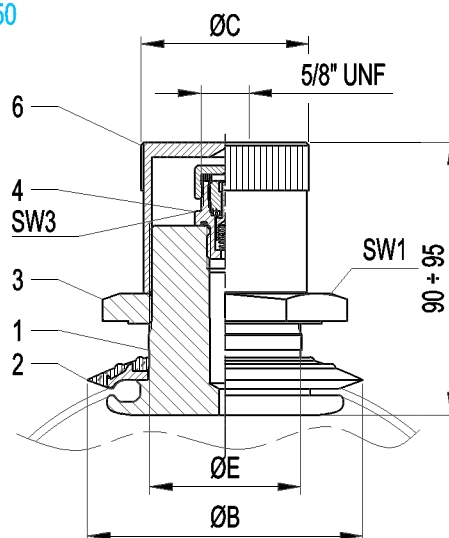
3.7d

3.7.7 VALVE DIMENSIONS AND SPARE PARTS CODE

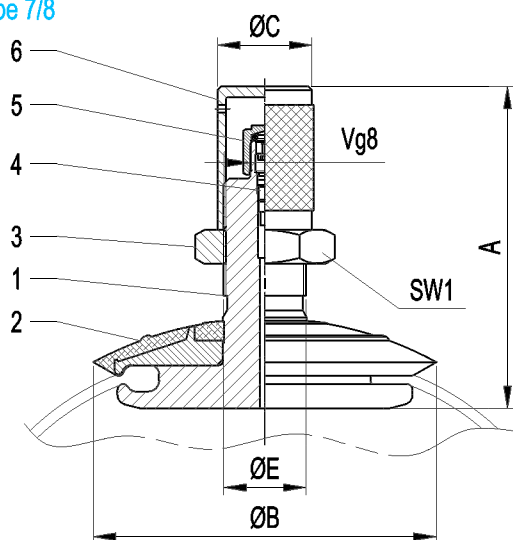
Type 5/8



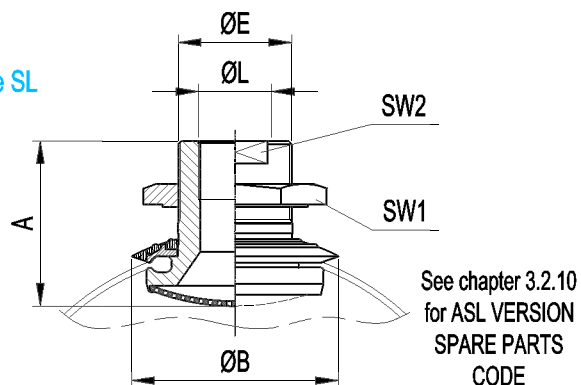
Type 50



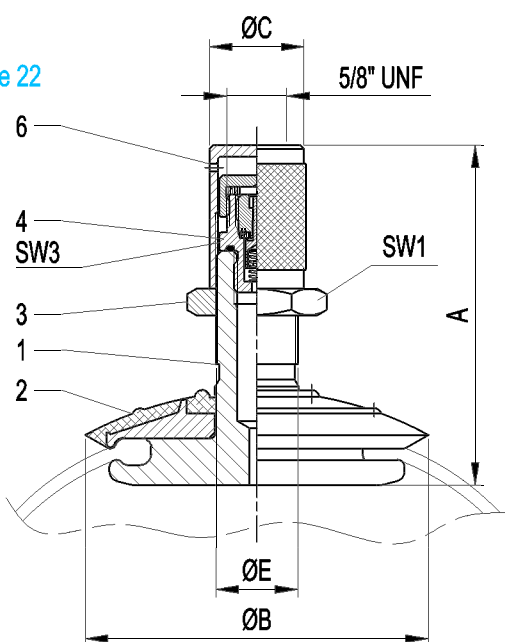
Type 7/8



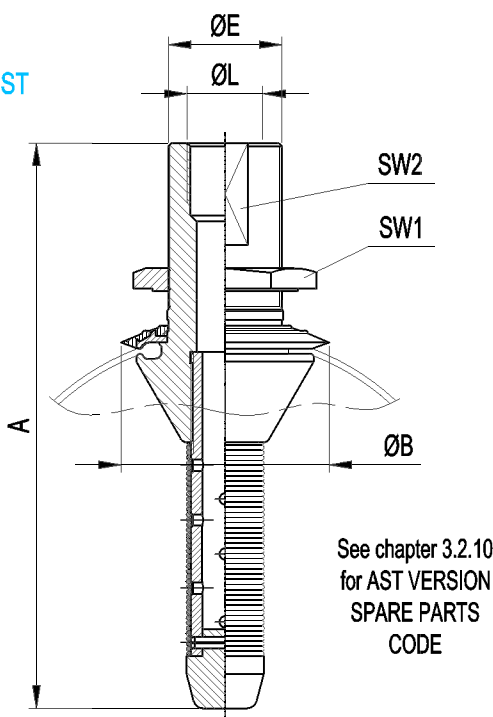
Type SL



Type 22



Type ST



3.7e

DIMENSIONS										
Nominal capacities (lt)	Valve type	Gas valve assembly	A mm	Ø B mm	Ø C mm	Ø E	Ø L	SW 1 mm	SW 2 mm	SW 3 mm
0,2	5/8	V 2002 - ** / *	40	34	20	5/8" UNF	-	24	-	-
	SL	V 2003 - ** / *	41	35	-	5/8" UNF	1/8" BSP	24	13	-
0,7	5/8	V 2015 - ** / *	45	48	20	5/8" UNF	-	24	-	-
	7/8	V 2020 - ** / *	65 ÷ 70	45	25	7/8" UNF	-	32	-	-
	22	V 2021 - ** / *	68 ÷ 73	45.5	25	M22x1.5	-	32	-	18
	SL	V 2027 - 1 - ** / *	48	45.5	-	M22x1.5	1/4" BSP	32	18	-
	ST	V 2456 - ** / *	236	45.5	-	M22x1.5	1/4" BSP	32	18	-
1 - 1,5 - 2,5 - 3	5/8	V 2015 - ** / *	45	48	20	5/8" UNF	-	24	-	-
	7/8	V 2020 - ** / *	65 ÷ 70	45	25	7/8" UNF	-	32	-	-
	22	V 2022 - ** / *	68 ÷ 73	45	25	M22x1.5	-	32	-	18
	SL	V 2027 - ** / *	48	45.5	-	M22x1.5	1/4" BSP	32	18	-
	ST	1-1,5-2,5 lt	V 2026 - ** / *	121	45	-	M22x1.5	1/4" BSP	32	18
3 lt		V 2029 - ** / *	236	45	-	M22x1.5	1/4" BSP	32	18	-
4 - 5	5/8	V 2041 - ** / *	55	65	20	5/8" UNF	-	24	-	-
	7/8	V 2046 - ** / *	75 ÷ 80	61.5	25	7/8" UNF	-	32	-	-
	22	V 2042 - ** / *	73 ÷ 78	61.5	25	M22x1.5	-	32	-	18
	ST	V 2043 - ** / *	201	61.5	-	M22x1.5	1/4" BSP	32	18	-
	SL	V 2048 - ** / *	57	61.5	-	M22x1.5	1/4" BSP	32	18	-
10 ÷ 55	7/8	V 2085 - ** / *	80 ÷ 90	91	25	7/8" UNF	-	32	-	-
	22	V 2061 - ** / *	80 ÷ 85	91	25	M22x1.5	-	32	-	18
	50	V 2062 - ** / *	90 ÷ 95	91	56	M50x1.5	-	70	-	18
	ST	AST 10-15 = V 2065 - ** / *	272	91	-	M50x1.5	1" BSP	70	46	-
		AST 20-25 = V 2066 - ** / *	395							
AST 35-55 = V 2067 - ** / *		495								
SL	V 2073 - ** / *	73	91	-	M50x1.5	1" BSP	70	41	-	

* Gasket material

** Component material

3.7f

Spare order codes										
Nominal capacities (lt)	Valve type	Ø E mm	Gas valve assembly	Pos. 1 valve body	Pos. 2 Rubber-coated washer	Pos. 3 locknut	Pos. 4 fill valve	Pos. 5 valve cap	Pos. 6 protect. cap	Weight kg
0,2	5/8	5/8" UNF	V 2002 - ** / *	B10026 - **	B10024 - ** / *	B10023 - **	V 2001 - ** / *	B10337/00 - ** - *	-	0,01
0,7	5/8	5/8" UNF	V 2015 - ** / *	B10110 - **	B10105 - ** / *	B10023 - **	V 2001 - ** / *	B10337/00 - ** - *	-	0,15
	7/8	7/8" UNF	V 2020 - ** / *	B10119 - **	B10104 - ** / *	B10108 - **	V 2069 - ** / *	B10134/00 - ** - *	B10135 - **	0,3
	22	M22x1.5	V 2021 - ** / *	B10107 - **	B10104 - ** / *	B10109 - **	V 2072 - ** / *	-	B10103 - **	0,28
1 - 1,5 - 2,5 - 3	5/8	5/8" UNF	V 2015 - ** / *	B10110 - **	B10105 - ** / *	B10023 - **	V 2001 - ** / *	B10337/00 - ** - *	-	0,15
	7/8	7/8" UNF	V 2020 - ** / *	B10119 - **	B10106 - ** / *	B10108 - **	V 2069 - ** / *	B10134/00 - ** - *	B10135 - **	0,3
	22	M22x1.5	V 2022 - ** / *	B10107 - **	B10106 - ** / *	B10109 - **	V 2072 - ** / *	-	B10103 - **	0,28
4 - 5	5/8	5/8" UNF	V 2041 - ** / *	B10255 - **	B10257 - ** / *	B10023 - **	V 2001 - ** / *	B10337/00 - ** - *	-	0,27
	7/8	7/8" UNF	V 2046 - ** / *	B10259 - **	B10205 - ** / *	B10108 - **	V 2069 - ** / *	B10134/00 - ** - *	B10135 - **	0,4
	22	M22x1.5	V 2042 - ** / *	B10202 - **	B10205 - ** / *	B10109 - **	V 2072 - ** / *	-	B10103 - **	0,4
10 ÷ 55	7/8	7/8" UNF	V 2085 - ** / *	B10330 - **	B10331 - ** / *	B10108 - **	V 2069 - ** / *	B10134/00 - ** - *	B10135 - **	0,75
	22	M22x1.5	V 2061 - ** / *	B10332 - **	B10331 - ** / *	B10109 - **	V 2072 - ** / *	-	B10103 - **	0,75
	50	M50x1.5	V 2062 - ** / *	B10333 - **	B10334 - ** / *	B10302 - **	V 2072 - ** / *	-	B10301 - **	1,54

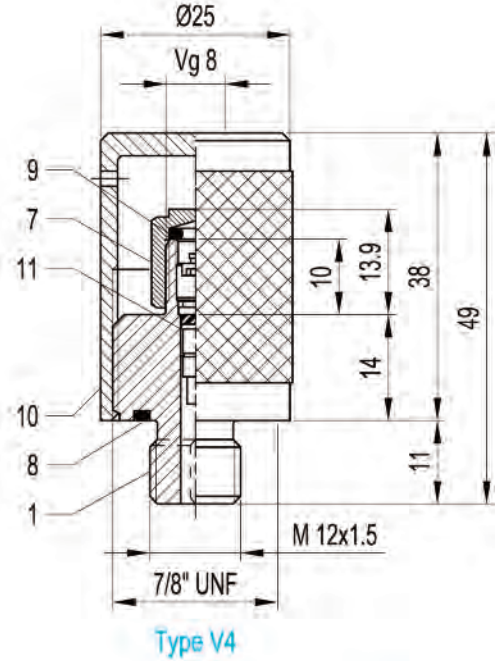
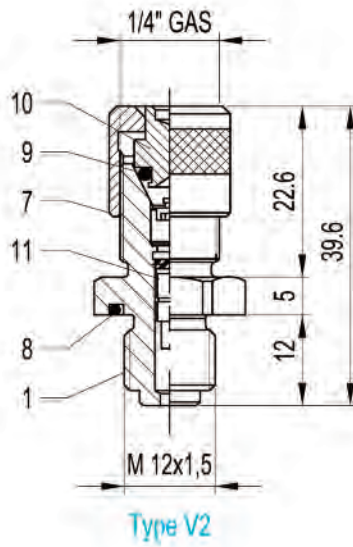
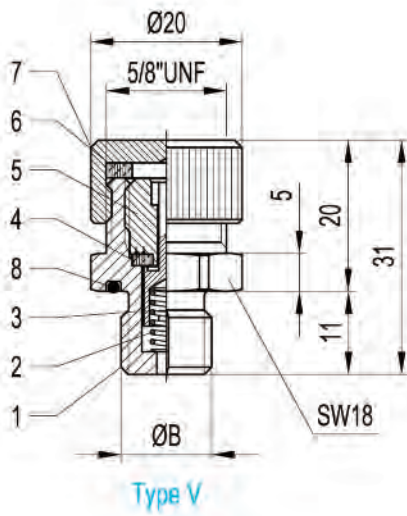
* Gasket material

** Component material

For ASL and AST type order code see chapter 3.2.10

3.7g

3.7.8 FILLING VALVES DIMENSIONS AND SPARE PARTS CODE



3.7h

Item	Description	Q.ty	Valve type				
			V / VX	VG2	VS1/2-20	V2	V4
1	Valve body	1	B10335 - **	B10335 - 1 - **	B10335 - 2 - **	B11605 - O	B10343 - 4 - **
2	Spring	1		B10339 - **		-	-
3	Pin	1		B10338 - **		-	-
4	Gasket pin	1		B10341 - *		-	-
5	Pin holder	1		B10340 - **		-	-
6	Gasket cap	1		B10342 - *		-	-
7	Valve cap	1		B10337 - **		B11603 - O	B10134 - O
8	Valve "O" ring	1			0010R2050 - *		
9	Valve cap "O" ring	1		-		0010R2018 - *	0010R0102 - *
10	Cap	1		-		B11604 - O	B10135 - **
11	Valve	1		-			V 2069-XP
Cap assembly (parts 7-9-10)				-		B11604A-0	-
Valve assembly			V 2072 - ** / *	V 2072 - 1 - ** / *	V 2072 - 2 - ** / *	V 2396 - O / *	V 2077 - 4 - ** / *
Ø B			M12x1,5	1/4" BSP	1/2" UNF	-	-
Weight				0,042		0,04	0,094

* Gasket material ** Component material

3.7i

3.7.9 MAINTENANCE

Handling

The original packaging is suitable for handling and storage. Where necessary, you should use suitable lifting equipment to support the weight of the accumulators.

However protect from impact the packaging and handle it with care.

Storage

During storage in the warehouse, leave the product in its original packaging, keeping it away from heat sources and naked flames. The storage temperature should be between +10 and +40°C. The maximum time of storage is two years. After time is no longer usable.

Disassembly bladder from gas valve

- First time remove the assembly bladder plus gas valve from accumulator shell



- Remove the rubber-coated washer.

3.7n



3.7l

- Remove the rubber-coated washer, if is necessary use a small tool for to leverage.



- Remove the gas valve, tilting slightly

3.7o



3.7m

- Remove the rubber-coated washer, and slip-off



- Remove the gas valve, by pulling the bladder.

3.7p



- Remove the gas valve, by pulling the bladder whit hand

3.7p

Assembly the new bladder with the gas valve



3.7r

- Put the gas body valve on the mouth of bladder and push.



3.7u

- Slip-on the rubber-coated washer.



3.7s

- Position the body gas valve.



3.7v

- Press the body gas valve and the rubber-coated washer forward the bladder .



3.7t

- Insert the rubber-coated washer.



3.7z

- Body gas valve correctly assembled.

Reproduction is forbidden.

In the spirit of continuous improvement, our products may be changed.



SCREWED DIAPHRAGM ACCUMULATORS type AM

5.1



FORGED DIAPHRAGM ACCUMULATORS type AML

5.2



WELDED DIAPHRAGM ACCUMULATORS type AMS

5.3

5.1.1 TECHNICAL DATA

MAX OPERATING PRESSURE (PS): (carbon steel) 210 - 330 bar
(stainless steel) 150 ÷ 210 bar

PRESSURE TEST (PT): 1,43 x PS

NOMINAL CAPACITIES: 0,05 - 0,1 - 0,35 - 0,5 - 0,75 - 1,5 - 2,5 litres

WORKING TEMPERATURE: -40 ÷ +150 °C

COMPRESSION RATIO (Po : P2): max 1 : 6

FLUID VISCOSITY RANGE: 10 ÷ 400 cSt

RECOMMENDED VISCOSITY: 36 cSt

FLUID CONTAMINATION DEGREE:
class 21/19/16 according to ISO 4406/99

BODY MATERIAL:

- carbon steel shell on painted with a black coat of rust inhibitor
- nickel coating 25 - 40 µ
- stainless steel AISI 316L
- duplex stainless steel SAF 2205

FILLING VALVE MATERIAL:

- galvanized carbon steel in compliance with Directive 2002/95/EC (RoHS) to resist to corrosion
- stainless steel AISI 316L

DIAPHRAGM MATERIAL:

- P = Nitrile rubber (NBR)
- F = Low temp. nitrile rubber
- K = Hydrogenated nitrile (HNBR)
- B = Butyl (IIR)
- E = Ethylene-propylene (EPDM)
- Y = Epichlorohydrin (ECO)
- V = Fluorocarbon (FPM)

See Table 5.1c and/or Chapter 1.5.

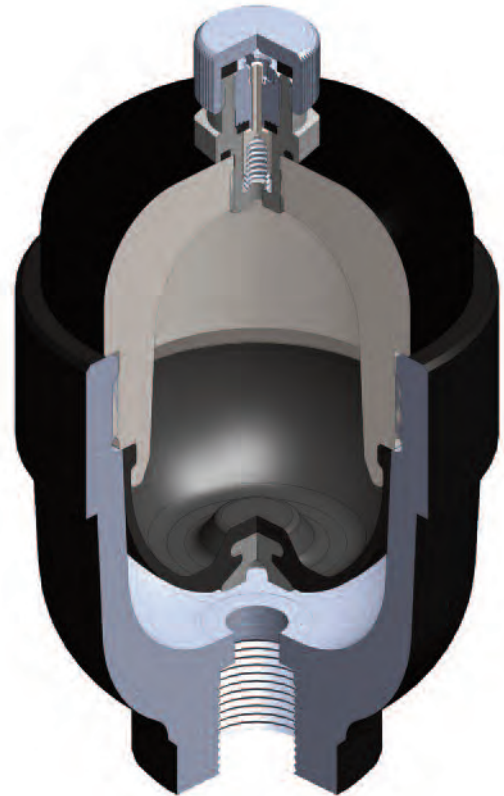
FILLING VALVE CONNECTION: - 5/8" UNF
FLUID PORT CONNECTION: - M18 x 1,5
- 1/2" - 3/4" BSP ISO228
- 1/2" - 3/4" NPT-F

FLOW RATE: see table 5.1e

WEIGHT: see table 5.1e

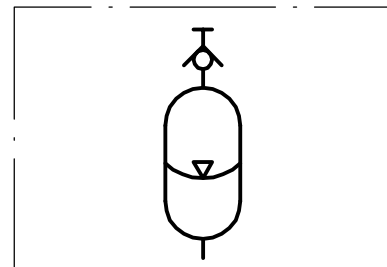
5.1.2 "AM" DIAPHRAGM ADVANTAGES

- dirt tolerant
- light weight
- compact
- simple construction
- quick response
- works well on water, low lubricity fluids
- quick, easy installation
- low cost



5.1a

5.1.3 HYDRAULIC SYMBOL



5.1b

5.1.4 DESCRIPTION

Diaphragm accumulators type "AM" are pressure vessels composed of a spherical or spherical-cylindrical shaped body in 2 or 3 pieces depending on its capacity. The separator of the diaphragm accumulators comprises an elastic diaphragm.

At the centre of the diaphragm, there is a metal disk, which serves to prevent the extrusion from the oil side in the event of complete discharge of the accumulator. The separator of the accumulators type "AM" can be replaced by removing the hemispherical caps.

The diaphragm has no friction. Therefore, there is no pressure drop between the oil and gas side. The diaphragm also has a low mass inertia. Diaphragm accumulators are then preferably used as shock absorbers and pulsation dampeners in the following sectors: industrial, machine tools, furniture and agriculture.

Accumulators type "AM" have a recommended compression ratio of 1:6, which, depending on the number of cycles of the loading and unloading time can also be of 1:8 without compromising the life of the diaphragm. Losses by diffusion of diaphragm accumulators are 1 ÷ 3% per year, de-

pending on the application characteristics.
The diaphragm may be made of different materials, so making the accumulators also suitable for corrosive liquids under pressure.
Compared to other accumulator types, the diaphragm ones have the hi-

ghest energy density (energy content / mass). This feature is due to the spherical shape of the accumulator shell.
For the diaphragm accumulators, you can choose any type of installation. The preferred assembly is, however, the vertical one.

5.1.5 DIAPHRAGM - TEMPERATURE - LIQUID COMPATIBILITY

When selecting the accumulator variant, pay attention to the following non-binding notes with regard to hydraulic fluid, diaphragm material and the permissive temperature range.

Code letter	Polymer	ISO	Temperature range (°C)	Some of the liquids compatible with the polymer
P	Standard nitrile (Perburan)	NBR	-20 ÷ +80	Aliphatic hydrocarbons (propane, butane, gasoline, oils, mineral greases, diesel fuel, fuel oil, kerosene), mineral greases and oils, HFA - HFB - HFC fluids, many dilute acids, alkalis, saline solutions, water, water glycol.
F	Low temperature nitrile	NBR	-40 ÷ +70	The same as with standard nitrile + a number of different types of Freon. (This contains less acrylonitrile than the standard and is therefore more suitable for low temperatures, but its chemical resistance is slightly lower).
K	Hydrogenated nitrile	HNB	-30 ÷ +130	The same as with standard nitrile but with excellent performance at high and low temperatures.
B	Butyl	IIR	-30 ÷ +100	Hot water up to 100°C, glycol-based brake fluids, many acids and bases, salt solutions, polar solvents such as alcohols, ketones and esters, polyglycol-based hydraulic fluids (HFC fluids) and bases of esters of phosphoric acid (HFD-R fluids), silicone oils and greases, Skydol 500 and 7000, resistance to ozone, aging and weathering.
E	Ethylene-Propylene	EPDM	-30 ÷ +100	Hot water up to 100°C, glycol-based brake fluids, many organic and inorganic acids, detergents, solutions of sodium and potassium, phosphate ester-based hydraulic fluids, (HFD-R), silicone oils and greases, many polar solvents (alcohol, ketones, esters), Skydol 500 and 7000, resistance to ozone, aging and weathering.
Y	Epichloridrin	ECO	-30 ÷ +110	Mineral oils and greases, aliphatic hydrocarbons (propane, butane and gasoline), silicone oils and greases, water at room temperature, resistance to ozone, aging and weathering.
V	Fluorocarbon	FPM	-10 ÷ +150	Mineral oils and greases, non-flammable fluids of HFD group, silicone oils and greases, animal and vegetable oils and greases, aliphatic hydrocarbons (gasoline, butane, propane, natural gas), aromatics hydrocarbons (benzene, toluene), chlorinated hydrocarbons (Tetrachloroethylene, carbon tetrachloride), fuel (regular, super and containing methanol), excellent resistance to ozone, weathering and aging.

For other hydraulic fluid and/or temperatures, please consult us.

5.1c

5.1.6 ORDER CODE

1	2	3	4	5	6	7	8	9	10
AM	0,5	P	210	C	G	4	V	- 0	/ 30

1 Series

Diaphragm accumulator = **AM**

2 Nominal capacity

0,05 lt = **0,05**
 0,1 lt = **0,1**
 0,35 lt = **0,35**
 0,5 lt = **0,5**
 0,75 lt = **0,75**
 1,5 lt = **1,5**
 2,5 lt = **2,5**

3 Diaphragm material

Nitrile rubber (NBR) = **P**
 Nitrile for low temp. = **F**
 Hydrogenated nitrile (HNBR) = **K**
 Butyl (IIR) = **B**
 Ethylene-propylene (EPDM) = **E**
 Epichlorohydrin (ECO) = **Y**
 Fluorocarbon (FPM) = **V**

4 Max working pressure (PS)

Capacity litres	Carbon steel	Stainless steel
0,05 =	210	150 - 210
0,1 =	210 - 330	150 - 210
0,35 =	210 - 330	150 - 210
0,5 =	210 - 330	150 - 210
0,75 =	210	150 - 210
1,5 =	210	150 - 210
2,5 =	210	150 - 210

10 Precharge pressure (bar)

Standard 30 bar = **0 ÷ 280** (< PS)

9 Test and certification

Factory testing = **0**
 TR (Russia) = **1**
 ML (China) = **3**
 PED97/23/EC(for capacity 1,5-2,5 l) = **8**
 ATEX 94/9EC = **9**
 RTN Passport (Russia) = **11**
 Algeria passport = **12**
 Standard regulation (NR13) (Brazil) = **13**
 Tunisia passport = **14**

8 Gas side connection

Standard filling valve with 5/8" UNF tread = **V**
 Standard filling valve with 5/8" UNF tread in stainless steel = **VX**

7 Dimension of connection side

For the type of connection:
 M = (Diameter/Pitch) **18/1,5**
 G (for capacity 0,05 ÷ 0,35 l) 1/2" = **4**
 G (for capacity 0,5 ÷ 2,5 l) 1/2" = **4**
 3/4" = **5**
 A (for capacity 0,5 ÷ 2,5 l) 3/4" = **5**
 P (for capacity 0,05 ÷ 0,35 l) 1/2" = **4**
 P (for capacity 0,5 ÷ 2,5 l) 1/2" = **4**
 3/4" = **5**

6 Fluid port connection

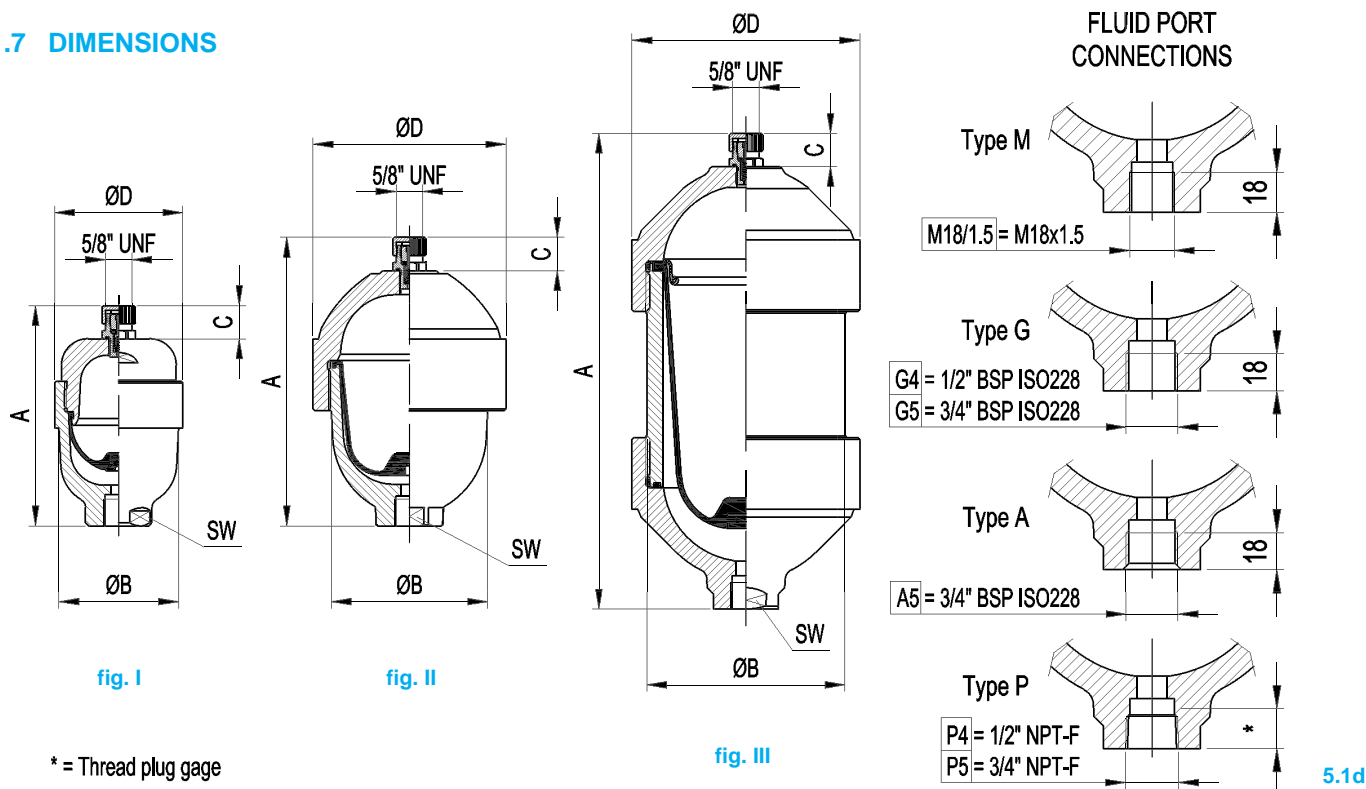
Metric = **M**
 BSP ISO 228 = **G**
 BSP ISO 228 with chamfer for OR = **A**
 NPT-F (standard for stainless steel) = **P**

5 Body material

Carbon steel = **C**
 Carbon steel nickel coated 25 µ = **N**
 Carbon steel nickel coated 40 µ = **M**
 Stainless steel (150 bar) = **X**
 Duplex stainless steel (210 bar) = **D**

Special variants upon request

5.1.7 DIMENSIONS



Accumulator type AM	Fig.	Nominal gas volume litres	Real gas volume litres	Working pressure bar	PED category for the liquids of group 2	Maximum differential pressure* bar	Flow rate** l/min	Maximum compression ratio Po/P2	A mm	Ø B mm	C mm	Ø D mm	SW mm	Dry weight Kg
AM 0,05	I	0,05	0,05	150 210	Art.3 (3)	110	10	1 : 6	108	65	20	65	41	1,3
AM 0,1	I	0,1	0,1	150 210 330	Art.3 (3)	110	10	1 : 6	130	73	20	77	36	1,6
AM 0,35	I	0,35	0,32	150 210 330	Art.3 (3)	110	40	1 : 6	160	94	20	99	36	2,6
AM 0,5	II	0,5	0,48	150 210 330	Art.3 (3)	110	40	1 : 6	175	94	20	116	36	3,6
AM 0,75	II	0,75	0,72	150 210	Art.3 (3)	110	40	1 : 6	190	115	20	137	41	5,6
AM 1,5	III	1,5	1,4	150 210	II	110	50	1 : 6	290	120	20	137	41	9,4
AM 2,5	III	2,5	2,4	150 210	II	110	60	1 : 6	445	120	20	137	41	13,2

* The maximum differential pressure is the maximum allowable difference between the maximum pressure and the minimum working pressure (P2-P1) to have an infinite life cycle of the accumulator (greater than 2,000,000 cycles).

** Flow rate measured using mineral oil with viscosity of 36 cSt at 50°C and $\Delta P = 5$ bar

5.1e

5.1.8 EUROPE MARKET

All hydraulic accumulators are pressure vessels and are subjected to the national regulations and directives, valid at the place of installation.

Diaphragm accumulators type AM, up to and including 1 litre, must not be CE marked.

For diaphragm accumulators type AM, greater than 1 litre, every shipping batch is provided with a conformity declaration a use and maintenance instructions and/or all the documents requested.

All vessel categories (see Table 5.1e) must be protected by means of a pressure relief valve in accordance with Directive 97/23/EC.

5.1.9 SPARE PARTS CODE

Item	Description	AM 0,05	AM 0,1	AM 0,35	AM 0,5	AM 0,75	AM 1,5	AM 2,5
1	P	MM0,05-P	MM0,1-P	MM0,35-P	MM0,5-P	MM0,75-P	MM1,5-P	MM2,5-P
	F	MM0,05-F	MM0,1-F	MM0,35-F	MM0,5-F	MM0,75-F	MM1,5-F	MM2,5-F
	K	MM0,05-K	MM0,1-K	MM0,35-K	MM0,5-K	MM0,75-K	MM1,5-K	MM2,5-K
	B	MM0,05-B	MM0,1-B	MM0,35-B	MM0,5-B	MM0,75-B	MM1,5-B	MM2,5-B
	E	MM0,05-E	MM0,1-E	MM0,35-E	MM0,5-E	MM0,75-E	MM1,5-E	MM2,5-E
	Y	MM0,05-Y	MM0,1-Y	MM0,35-Y	MM0,5-Y	MM0,75-Y	MM1,5-Y	MM2,5-Y
	V	MM0,05-V	MM0,1-V	MM0,35-V	MM0,5-V	MM0,75-V	MM1,5-V	MM2,5-V
2	Gas valve	V	V2072-CP	V2072-CP	V2072-CP	V2072-CP	V2072-CP	V2072-CP
		VX	V2072-XP	V2072-XP	V2072-XP	V2072-XP	V2072-XP	V2072-XP
3	Seal kit	P					KG2087-P	KG2087-P
		F					KG2087-F	KG2087-F
		K					KG2087-K	KG2087-K
		B					KG2087-B	KG2087-B
		E					KG2087-E	KG2087-E
		Y					KG2087-Y	KG2087-Y
		V					KG2087-V	KG2087-V

5.1f

5.1.10 ACCESSORIES

For clamps see section 7

For safety blocks see section 9

For pre-loading and charging set see section 11

For pulse damper adapters see section 12.1

5.1.11 COMMISSIONING AND MAINTENANCE

Delivery condition

Diaphragm accumulators are delivered pre-charged with nitrogen at a pressure of 30 bar or at value of pressure required at time of order.

The preload value is still on the nameplate of the accumulator.

Depending on the size and quantity ordered, the diaphragm accumulators are shipped in boxes or in cartons or on pallets, or wooden boxes on request.

Unless otherwise required certificates and documentation are provided together with the accumulators.

Handling

The original packaging is suitable for handling and general storage.

Where necessary, you should use suitable lifting equipment to support the weight of the accumulators.

Protect from impact, however, the packaging and handle it with care.

Storage

During storage in the warehouse, leave the product in its original packaging, keeping it away from heat sources and naked flames. The storage temperature should be between +10 and +40°C.

After six years of storage, it is essential to proceed with the replacement of all elastomeric parts before the commissioning.

Marking on the nameplate of the accumulator

With reference to the PED 97/23/EC classification, Article 3, Paragraph 3 and / or risk categories I or II according to the amount and maximum working pressure, the accumulator indicates the following

- logo, name and country of the manufacturer
- product code
- Month / year of production
- Serial number
- Maximum PS pressure and PT test pressure in bar
- Min. and max. TS working temperature in Celsius
- Volume V in litres
- Group of fluids allowed (II)
- CE marking (by volume exceeding 1 litre) with the identification number of the notified body
- Pre-charge pressure in bar

It is strictly forbidden to:

- weld, rivet or screw any item of the accumulator
- engrave or permanently stamp the surfaces of the accumulator shell and / or carry out other operations that could affect or change the mechanical properties of the accumulator
- use the accumulator as a structural element: it should not be subjected to stresses or loads
- change the data of the nameplate and / or accumulator without the permission of the manufacturer
- use a (dangerous) fluid of Group 1 with equipment designed and manufactured for fluids of Group 2.

Installation

Before installation, you must perform a visual check to verify that the accumulator has not suffered any damage during shipping / handling.

Verify that the requested type matches with what stamped on the nameplate. The accumulator can be mounted in any position.

We recommend using the accumulator with a suitable safety valve (see section 8) or with a safety blocks type BS (see section 9).

This device provides user and equipment protection against possible damage caused by pressure surges, and also makes the maintenance of the accumulator easier, so facilitating the interception and the discharge.

Provide for a clearance of 200 mm above the gas pre-charge valve to allow access to and control of the pre-charge equipment (see Chap.11). The accumulators type AM may be installed in any position from horizontal to vertical (preferably with the pre-charge valve at the top), and the nameplate must be visible.

Proceed to the assembly so that no abnormal force affects the pipes connected directly or indirectly to the accumulator, so we recommend the use of supporting components and also fastening (please see section 7) to avoid the transmission of vibrations.

In the absence of the use of safety EPE blocks, make sure that the accumulator is connected to the hydraulic circuit through appropriate connecting devices.

Make sure the fluid is compatible with the elastomer of the diaphragm. Check that the max. allowed accumulator pressure is equal to or greater than that of the hydraulic circuit and that the temperature during operation is maintained within the range expected.

Make sure the fluid does not contain contaminants and/or abrasive.

Pre-charge of nitrogen

Normally, the diaphragm accumulators are delivered pre-charged with pressurized gas. The pre-charge of gas can be controlled and / or adjusted before or after installation of the accumulator in the hydraulic circuit. For the pre-charge, use only industrial dry nitrogen with a purity of min. 99%. It is important to use the nitrogen from a cylinder equipped with a pressure reducing valve (see Chap.11.3). Use the EPE pre-loading and charging set type PC to check the charging pressure Calculated Against the pressure, and adjust if necessary.

If the pre-charge pressure is lower than required, connect the inflation tube on one side and the other of the equipment. Connect it to the cylinder of nitrogen or to the pressure reducer.

Slowly enter the nitrogen in the accumulator until reaching a pressure slightly higher than that set (+ 10 ÷ 15%).

Close the cylinder and remove the connecting pipe from the equipment; wait until the gas temperature has stabilized (1 hour) and calibrate the pressure, discharging the excess gas.

Make sure that the gas pipe is not subject to losses and, if necessary, use soap and water.

Tighten the protective cap manually.

Hydraulic pressurization

- Check that the pre-charge pressure is adequate for the application
- Ensure that the hydraulic pressure never exceeds the max. (PS) allowed and shown on the accumulator shell.

To avoid this risk, use a safety item (see section 9).

Maintenance

- Periodically check the pre-charge pressure of the gas: after the commissioning, check after 2-3 weeks of operation and if there were no leaks, repeat the operation after 3 months; if the pressure at the same temperature was stable, repeat the test at annual intervals.

For heavy-duty applications, check the pre-charge every 6 months.

- Periodically (annually) carry out a visual inspection of the accumulator in order to detect any early signs of deterioration such as corrosion, deformation, etc.
- Comply with the requirements of the regulations concerning the verification of the functionality of the equipment according to the country of installation of the accumulator.

Disassembly

If for failure, scheduled check or retest it is necessary to remove the accumulator from the system, prior to removal, isolate the accumulator from the installation and discharge pressure of the liquid.

All diaphragm EPE accumulators of the AM series may be repaired.

- Fix the bottom in a vice.
 - Remove the pre-charge valve (after having discharged completely the nitrogen).
 - Unscrew the top cap with a strap wrench or a spanner.
- Remove the diaphragm and any seal.

Repair

It may consist in replacing the diaphragm, seals (if any) or pre-charging valve 5/8"UNF.

For reasons of functionality and security, it is recommended to use only original spare parts.

Before starting the repair, drain completely the nitrogen contained in the accumulator.

Refitting

After thorough cleaning, check and replace the damaged components.

The exterior of the diaphragm and any seal must be wetted with the working liquid.

Replace the cover and tighten it firmly.

Finally, replace the pre-charge valve with a tightening torque of 35 Nm.

Pre-charge

- Screw the pre-charge PC equipment on the gas valve.
- Connect the equipment to the cylinder of nitrogen or to the pressure reducer with the inflation tube.
- Slowly enter the nitrogen in the accumulator until reaching a pressure slightly higher than the set value (+ 10 ÷ 15%).
- Close the cylinder and remove the connecting pipe from the equipment.
- Wait until the gas temperature has stabilized (2 hours).
- Calibrate the pressure discharging the excess gas.

Demolition and recycling of the accumulator

Before accumulator demolition or recycling, you should always discharge completely the pre-charge pressure and remove the gas valve.

If you need, proceed decontaminating in relation to the fluid used prior to demolition.

Reproduction Is Forbidden.

In The Spirit Of Continuous Improvement, Our Products May Be Changed.

5.2.1 TECHNICAL DATA

MAX OPERATING PRESSURE (PS): (carbon steel) 250 - 350 bar
(stainless steel) 150 ÷ 210 bar

PRESSURE TEST (PT): 1,43 x PS

NOMINAL CAPACITIES: 0.8 - 1.5 litres

WORKING TEMPERATURE: -40 ÷ +150 °C

COMPRESSION RATIO (Po : P2): max 1 : 6

FLUID VISCOSITY RANGE: 10 ÷ 400 cSt

RECOMMENDED VISCOSITY: 36 cSt

FLUID CONTAMINATION DEGREE:
class 21/19/16 according to ISO 4406/99

BODY MATERIAL:

- carbon steel shell on painted with a black coat of rust inhibitor
- nickel coating 25 - 40 µ
- stainless steel AISI 316L
- duplex stainless steel SAF 2205

FILLING VALVE MATERIAL:

- galvanized carbon steel in compliance with Directive 2002/95/EC (RoHS) to resist to corrosion
- stainless steel AISI 316L

DIAPHRAGM MATERIAL:

- P = Nitrile rubber (NBR)
- F = Low temp. nitrile rubber
- K = Hydrogenated nitrile (HNBR)
- B = Butyl (IIR)
- E = Ethylene-propylene (EPDM)
- Y = Epichlorohydrin (ECO)
- V = Fluorocarbon (FPM)

See Table 5.2c and /or Chapter 1.5

FILLING VALVE CONNECTION: 5/8" UNF

FLUID PORT CONNECTION:

- M18 x 1,5
- 1/2" - 3/4" BSP ISO228
- 1/2" - 3/4" NPT-F

FLOW RATE: see table 5.2d

WEIGHT: see table 5.2d

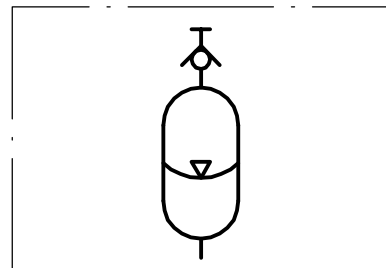
5.2.2 "AML" DIAPHRAGM ADVANTAGES

- dirt tolerant
- light weight
- compact
- simple construction
- quick response
- works well on water, low lubricity fluids
- quick, easy installation
- low cost



5.2a

5.2.3 HYDRAULIC SYMBOL



5.2b

5.2.4 DESCRIPTION

Diaphragm accumulators type "AML" are pressure vessels composed of a forged shell, whose ends have a semi-spherical shape. The separator of the diaphragm accumulators comprises an elastic diaphragm.

At the centre of the diaphragm, there is a metal disk, which serves to prevent the extrusion from the oil side in the event of complete discharge of the accumulator.

The separator of the accumulators type "AML" can be replaced by removing the ring nuts on the gas site.

The diaphragm has very low friction. Therefore, the pressure drop between the oil and gas side is irrelevant. The diaphragm also has a low mass inertia. Diaphragm accumulators are then preferably used as shock absorbers and pulsation dampeners in the following sectors: industrial, machine tools, furniture and agriculture.

Accumulators type "AML" have a recommended compression ratio of 1:6, which, depending on the number of cycles of the loading and unloading time can also be of 1:8 without compromising the life of the dia-

phragm. Losses by diffusion of diaphragm accumulators are $1.5 \div 4\%$ per year, depending on the application characteristics.

The diaphragm may be made of different materials, so making the accu-

mulators also suitable for corrosive liquids under pressure.

For the diaphragm accumulators, you can choose any type of installation.

The preferred assembly is, however, the vertical one.

5.2.5 DIAPHRAGM - TEMPERATURE - LIQUID COMPATIBILITY

When selecting the accumulator variant, pay attention to the following non-binding notes with regard to hydraulic fluid, diaphragm material and the permissive temperature range.

Code letter	Polymer	ISO	Temperature range (°C)	Some of the liquids compatible with the polymer
P	Standard nitrile (Perburan)	NBR	-20 ÷ +80	Aliphatic hydrocarbons (propane, butane, gasoline, oils, mineral greases, diesel fuel, fuel oil, kerosene), mineral greases and oils, HFA - HFB - HFC fluids, many dilute acids, alkalis, saline solutions, water, water glycol.
F	Low temperature nitrile	NBR	-40 ÷ +70	The same as with standard nitrile + a number of different types of Freon. (This contains less acrylonitrile than the standard and is therefore more suitable for low temperatures, but its chemical resistance is slightly lower).
K	Hydrogenated nitrile	HNB	-30 ÷ +130	The same as with standard nitrile but with excellent performance at high and low temperatures.
B	Butyl	IIR	-30 ÷ +100	Hot water up to 100°C, glycol-based brake fluids, many acids and bases, salt solutions, polar solvents such as alcohols, ketones and esters, polyglycol-based hydraulic fluids (HFC fluids) and bases of esters of phosphoric acid (HFD-R fluids), silicone oils and greases, Skydol 500 and 7000, resistance to ozone, aging and weathering.
E	Ethylene-Propylene	EPDM	-30 ÷ +100	Hot water up to 100°C, glycol-based brake fluids, many organic and inorganic acids, detergents, solutions of sodium and potassium, phosphate ester-based hydraulic fluids, (HFD-R), silicone oils and greases, many polar solvents (alcohol, ketones, esters), Skydol 500 and 7000, resistance to ozone, aging and weathering.
Y	Epichloridrin	ECO	-30 ÷ +110	Mineral oils and greases, aliphatic hydrocarbons (propane, butane and gasoline), silicone oils and greases, water at room temperature, resistance to ozone, aging and weathering.
V	Fluorocarbon	FPM	-10 ÷ +150	Mineral oils and greases, non-flammable fluids of HFD group, silicone oils and greases, animal and vegetable oils and greases, aliphatic hydrocarbons (gasoline, butane, propane, natural gas), aromatics hydrocarbons (benzene, toluene), chlorinated hydrocarbons (Tetrachloroethylene, carbon tetrachloride), fuel (regular, super and containing methanol), excellent resistance to ozone, weathering and aging.

5.2c

For other hydraulic fluid and/or temperatures, please consult us.

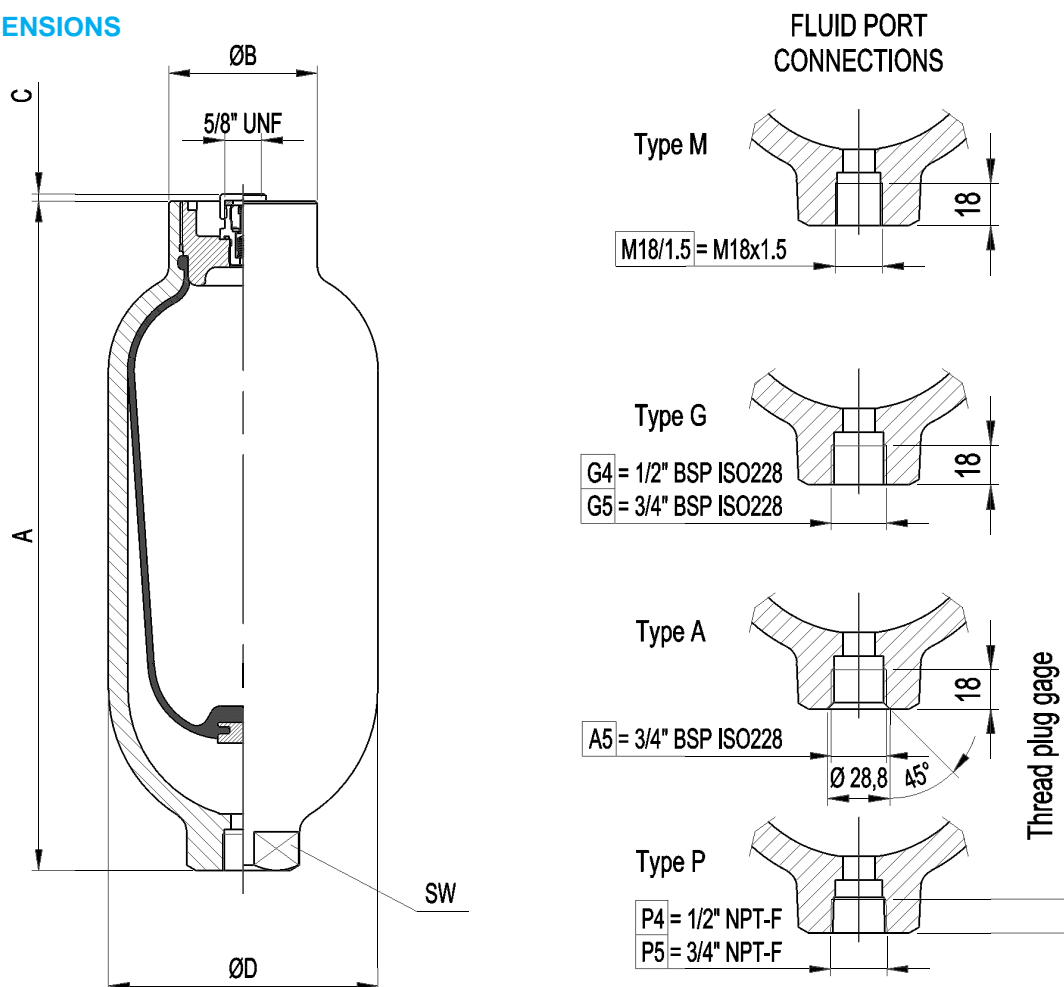
5.2.6 ORDER CODE

1 2 3 4 5 6 7 8 9 10
AML 1,5 P 250 C M 18/1,5 V - 8 / 30

1 Series Diaphragm accumulator = AML	10 Precharge pressure (bar) Standard 30 bar = 0 ÷ 280 (< PS)									
2 Nominal capacity 0,8 lt = 0,8 1,5 lt = 1,5	9 Test and certification Factory testing = 0 TR (Russia) = 1 ML (China) = 3 PED97/23/EC(for capacity 1,5) = 8 ATEX 94/9EC = 9 RTN Passport (Russia) = 11 Algeria passport = 12 Standard regulation (NR13) (Brazil) = 13 Tunisia passport = 14									
3 Diaphragm material Nitrile rubber (NBR) = P Nitrile for low temp. = F Hydrogenated nitrile (HNBR) = K Butyl (IIR) = B Ethylene-propylene (EPDM) = E Epichlorohydrin (ECO) = Y Fluorocarbon (FPM) = V	8 Gas side connection Standard filling valve with 5/8" UNF tread = V Standard filling valve with 5/8" UNF tread in stainless steel = VX									
4 Max working pressure (PS) <table border="1"> <thead> <tr> <th>Capacity litres</th> <th>Carbon steel</th> <th>Stainless steel</th> </tr> </thead> <tbody> <tr> <td>0,8 =</td> <td>250 - 350</td> <td>150 - 210</td> </tr> <tr> <td>1,5 =</td> <td>250 - 350</td> <td>150 - 210</td> </tr> </tbody> </table>	Capacity litres	Carbon steel	Stainless steel	0,8 =	250 - 350	150 - 210	1,5 =	250 - 350	150 - 210	7 Dimension of connection side For the type of connection: M = (Diameter/Pitch) 18/1,5 G 1/2" = 4 3/4" = 5 A 3/4" = 5 P 1/2" = 4 3/4" = 5
Capacity litres	Carbon steel	Stainless steel								
0,8 =	250 - 350	150 - 210								
1,5 =	250 - 350	150 - 210								
5 Body material Carbon steel = C Carbon steel nickel coated 25 µ = N Carbon steel nickel coated 40 µ = M Stainless steel (150 bar) = X Duplex stainless steel (210 bar) = D	6 Fluid port connection Metric = M BSP ISO 228 = G BSP ISO 228 with chamfer for OR = A NPT-F (standard for stainless steel) = P									

Special variants on request

5.2.7 DIMENSIONS



5.2d

Accumulator type AML	Nominal gas volume	Real gas volume	Working pressure	PED category for the liquids of group 2	Maximum differential pressure*	Flow rate**	Maximum compression ratio	A	Ø B	C	Ø D	SW	Dry weight
volume	litres	litres	bar		bar	l/min	Po/P2	mm	mm	mm	mm	mm	Kg
AML 0,8	0,8	0,8	150	Art.3 (3)	110	40	1 : 6	200	65	3	116	36	4,5
			210										
			250										
			350										
AML 1,5	1,5	1,5	150	II	110	40	1 : 6	295	65	3	116	36	5,6
			210										
			250										
			350										

* The maximum differential pressure is the maximum allowable difference between the maximum pressure and the minimum working pressure (P2-P1) to have an infinite life cycle of the accumulator (greater than 2,000,000 cycles).

** Flow rate measured using mineral oil with viscosity of 36 cSt at 50°C and $\Delta P = 5$ bar

5.2e

5.2.8 EUROPE MARKET

All hydraulic accumulators are pressure vessels and are subjected to the national regulations and directives, valid at the place of installation. Diaphragm accumulators type AML, up to and including 1 litre, must not be CE marked.

For diaphragm accumulators type AML, greater than 1 litre, every shipping batch is provided with a conformity declaration, use and maintenance instructions and/or all the documents requested.

All vessel categories (see Table 5.1c) must be protected by means of a pressure relief valve in accordance with Directive 97/23/EC.

5.2.9 SPARE PARTS CODE

Item	Description	AML 0,8	AML 1,5	
1	Diaphragm	P	ML0,8-P	ML1,5-P
		F	ML0,8-F	ML1,5-F
		K	ML0,8-K	ML1,5-K
		B	ML0,8-B	ML1,5-B
		E	ML0,8-E	ML1,5-E
		Y	ML0,8-Y	ML1,5-Y
	V	ML0,8-V	ML1,5-V	
2	Gas valve	V	V2072-CP	V2072-CP
		VX	V2072-XP	V2072-XP

5.2f

5.2.10 ACCESSORIES

For clamps see section 7

For safety blocks see section 9

For pre-loading and charging set see section 11

For pulse damper adapters see section 12.1

5.2.11 COMMISSIONING AND MAINTENANCE

Delivery condition

Diaphragm accumulators are delivered pre-charged with nitrogen at a pressure of 30 bar or at value of pressure required at time of order.

The pre-charge value is still on the nameplate of the accumulator.

Depending on the size and quantity ordered, the diaphragm accumulators are shipped in boxes, in cartons, on pallets or wooden boxes on request.

Unless required, certificates and documentation are provided together with the accumulators.

Handling

The original packaging is suitable for handling and general storage.

Where necessary, you should use suitable lifting equipment to support the weight of the accumulators.

However protect from impact the packaging and handle it with care.

Storage

During storage in the warehouse, leave the product in its original packaging, keeping it away from heat sources and naked flames. The storage temperature should be between +10 and +40°C.

After six years of storage, it is essential to proceed with the replacement of all elastomeric parts before the commissioning.

Marking on the nameplate of the accumulator

With reference to the PED 97/23/EC classification, Article 3, Paragraph 3 and / or risk categories I or II depending on the volume and maximum working pressure, the accumulator indicates the following data:

- Month / year of production
- logo, name and country of the manufacturer
- product code
- Serial number
- Maximum pressure PS and test pressure PT in bar
- Min. and max. working temperature TS in Celsius
- Volume V in litres
- Group of fluids allowed (II)

- CE marking (for volumes exceeding 1 litre) with the identification number of the notified body
- Pre-charge pressure in bar

It is strictly forbidden to:

- engrave or permanently stamp the surfaces of the accumulator shell and / or carry out other operations that could affect or change the mechanical properties of the accumulator
- use the accumulator as a structural element: it should not be subjected to stresses or loads
- change the data of the nameplate and / or accumulator without the permission of the manufacturer
- use a (dangerous) fluid of Group 1 with equipment designed and manufactured for fluids of Group 2.

Installation

Before installation, you must perform a visual check to verify that the accumulator has not suffered any damage during shipping / handling.

Verify that the requested type matches with what stamped on the nameplate.

We recommend using the accumulator with a suitable security valve (see section 8) or a security block type BS (see section 9). This device provides user and equipment protection against possible damage caused by pressure surges and also makes the maintenance of the accumulator easier, and facilitate the interception and the discharge.

Provide for a spare of 200 mm above the gas pre-charge valve to allow access to and control of the pre-charge equipment (see section 11.2).

The accumulators type AML may be installed in any position from horizontal to vertical (preferably with the pre-charge valve at the top), and the nameplate must be visible.

Proceed to the assembly so that no abnormal force affects the pipes connected directly or indirectly to the accumulator, so we recommend the use of supporting components and also fastening (please see Chapter 7) to avoid the transmission of vibrations.

Make sure the fluid is compatible with the elastomer of the diaphragm. Check that the max. allowed accumulator pressure is equal to or greater than that of the hydraulic circuit and that the temperature during operation is maintained within the range expected.

Make sure the fluid does not contain contaminants and/or abrasive.

Pre-charge of nitrogen

Normally, the diaphragm accumulators are delivered pre-charged with pressurized gas. The pre-charge of gas can be controlled and / or adjusted before or after installation of the accumulator in the hydraulic circuit. For the pre-charge, use only industrial dry nitrogen with a purity of min. 99%. It is important to use the nitrogen from a cylinder equipped with a pressure reducing valve (see section 11.3). Use the EPE pre-charge and charging set type PC to check the charging pressure required and adjust if necessary.

If the pre-charge pressure is lower than required, connect the charging nose to the pre-loading set on one side and the other side connect it to the nitrogen bottle or to the pressure reducer. Slowly free the nitrogen in the accumulator until reaching a pressure slightly higher than the set value (+ 10 ÷ 15%).

Close the bottle and remove the charging nose from the pre-loading set; wait until the gas temperature has stabilized (1 hour) and calibrate the pressure, discharging the excess gas. Make sure that the gas pipe is not subject to losses and, if necessary, use soap and water.

Tighten the protective cap manually.

Hydraulic pressurization

- Check that the pre-charge pressure is adequate for the application
- Ensure that the hydraulic pressure never exceeds the max. allowed pressure (PS) and shown on the accumulator shell.

To avoid this risk, use a safety device (see Chap. 9).

Maintenance

- Periodically check the pre-charge pressure of the gas: after the commissioning, check after 2-3 weeks of operation and if there were no leaks, repeat the operation after 3 months; if the pressure at the same temperature was stable, repeat the test at yearly. For heavy duty applications, check the pre-charge every 6 months.
- Periodically (yearly) carry out a visual inspection of the accumulator in order to detect any early signs of deterioration such as corrosion, deformation, etc.
- Comply with the requirements of the regulations concerning the verification of the functionality of the equipment according to the country of installation of the accumulator.

Disassembly

If for failure, scheduled check or retest it is necessary to remove the accumulator from the system, prior to removal, isolate the accumulator from the installation and discharge pressure of the liquid.

All diaphragm EPE accumulators of the AML series may be repaired.

- Fix the bottom in a vice simply.
- Remove the pre-charge valve (after having discharged completely the nitrogen).
- Unscrew the upper internal nut ring with a suitable wrench.

Remove the diaphragm.

Repair

It may consist in replacing the pre-charge valve of 5/8" UNF. For reasons of functionality and security, it is recommended to use only original spare parts. Before starting the repair, discharge completely the nitrogen contained in the accumulator.

Reassembling

After thorough cleaning, check and replace the damaged components. The exterior of the diaphragm must be wetted with the working liquid.

Refit the nut ring and tighten it firmly.

Finally, refit the pre-charge valve with a tightening torque of 35 Nm.

Pre-charge

- Screw the pre-charge PC equipment on the gas valve.
- Connect the equipment to the bottle of nitrogen or to the pressure reducer with the charging nose.
- Slowly jill the nitrogen in the accumulator until reaching a pressure slightly higher than the set value (+ 10 ÷ 15%).
- Close the bottle and remove the charging nose from the equipment.
- Wait until the gas temperature has stabilized (2 hours).
- Calibrate the pressure discharging the excess gas.

Demolition and recycling of the accumulator

Before accumulator demolition or recycling, you should always discharge completely the pre-charge pressure and remove the gas valve.

If you need, proceed decontaminating in relation to the fluid used prior to demolition.

Reproduction Is Forbidden.

In The Spirit Of Continuous Improvement, Our Products May Be Changed.

5.3.1 TECHNICAL DATA

MAX OPERATING PRESSURE (PS):

(carbon steel) 100 – 160 – 210 - 250 - 350 bar
 (stainless steel) 100 bar (other, upon request)

PRESSURE TEST (PT): 1,43 x PS

NOMINAL CAPACITIES: litres

0.075 - 0.16 - 0.25 - 0.32 - 0.5 - 0.75 - 1 - 1.4 - 2 - 2.8 - 3.5

WORKING TEMPERATURE: -40 ÷ +80 °C

COMPRESSION RATIO (Po : P2): max 1 : 8; see Tab.5.3e

FLUID VISCOSITY RANGE: 10 ÷ 400 cSt

RECOMMENDED VISCOSITY: 36 cSt

FLUID CONTAMINATION DEGREE:

class 21/19/16 according to ISO 4406/99

BODY MATERIAL: - carbon steel shell painted with a black rust inhibitor coat
 - stainless steel AISI 316L

FILLING VALVE MATERIAL (internal screw):

- galvanized carbon steel in compliance with Directive 2002/95/CE (RoHS) to resist to corrosion
 - stainless steel AISI 316L

DIAPHRAGM MATERIAL:

- P = Nitrile rubber (NBR)
 - Y = Epichlorohydrin (ECO)

See Table 5.3c and /or Chapter 1.5

FILLING VALVE CONNECTION:

- M28 x 1.5
 - without and closed

FLUID PORT CONNECTION:

- internal thread:
 1/2" - 3/4" BSP ISO228
 - external thread: M33x1.5
 M45x1.5

See Table 5.3e

FLOW RATE: see Table 5.3e

WEIGHT: see Table 5.3e

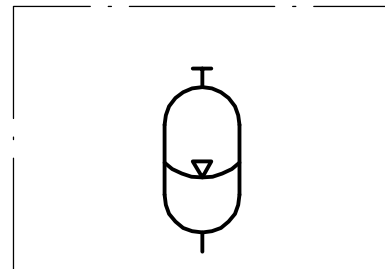
5.3.2 "AMS" DIAPHRAGM ADVANTAGES

- high compression ratio
- dirt tolerant
- light weight
- compact
- simple construction
- quick response
- permanently sealed for maintenance free operation
- works well on low lubricity fluids
- quick, easy installation and replacement
- can be mounted in any position
- long service life
- low cost



5.2a

5.3.3 HYDRAULIC SYMBOL



5.2b

5.3.4 DESCRIPTION

The welded type diaphragm accumulators cannot be repaired, as they are specially designed for high quantity and economical applications, where it is more practical to replace the unit rather than refurbishing it. These accumulators consist of a shell manufactured with a high strength alloy steel and a welded electron-beam.

The flexible diaphragm provides excellent gas and fluid separation. Diaphragm are available in two compounds:

- "P" nitrile (NBR)
- "Y" hydrin (ECO)

The button closes the fluid port when the accumulator is fully discharged to prevent diaphragm extrusion.

The fluid port is available provided with two types of connections:

- "G" BSP UNI228 female
- "W" BSP UNI228 female and external metric male

The gas valve is available in two versions:

- "VT" fixed pre-charge
- "VM" metric M28x1.5 gas valve and leak-free. It offers flexibility of checking or charging the accumulator (see charging kit type PCM).

This rugged gas valve features an internal hexagonal locking screw with sealing washer.

Diaphragm accumulators type AMS are then preferably used as shock absorbers and pulsation dampeners in the following sectors: industrial, machine tools, furniture and agriculture.

Compared to other accumulator types, the diaphragm ones have the highest energy density (energy content / mass). This feature is due to the spherical shape of the accumulator shell.

For the diaphragm accumulators, you can choose any type of installation. The preferred assembly is, however, the vertical one.

5.3.5 DIAPHRAGM - TEMPERATURE - LIQUID COMPATIBILITY

When selecting the accumulator variant, pay attention to the following non-binding notes with regard to hydraulic fluid, diaphragm material and the permissive temperature range.

Code letter	Polymer	ISO	Temperature range (°C)	Some of the liquids compatible with the polymer
P	Standard nitrile (Perburan)	NBR	-20 ÷ +80	Idrocarburi alifatici (propano, butano, benzina, olii, grassi minerali, carburante diesel, olio combustibile, kerosene), grassi ed olii minerali, fluidi HFA - HFB - HFC, molti acidi diluiti, alcali, soluzioni saline, acqua, acqua glicole
Y	Epichloridrin	ECO	-30 ÷ +110	Mineral oils and greases, aliphatic hydrocarbons (propane, butane and gasoline), silicone oils and greases, water at room temperature, resistance to ozone, aging and weathering.

For other hydraulic fluid and/or temperatures, please consult us.

5.3c

5.3.6 ORDER CODE

1 2 3 4 5 6 7 8 9 10
AMS 1 P 210 C G 4 VM - 0 / 30

1	Series
Diaphragm accumulator = AMS	

2	Nominal capacity
	0,075 lt = 0,075
	0,16 lt = 0,16
	0,32 lt = 0,32
	0,5 lt = 0,5
	0,75 lt = 0,75
	1 lt = 1
	1,4 lt = 1,4
	2 lt = 2
	2,8 lt = 2,8
	3,5 lt = 3,5

3	Diaphragm material
Gomma nitrilica (NBR)	= P
Epicloridrina (ECO)	= Y

4	Max working pressure (PS)		
Capacity (litres)	Carbon steel (bar)	Stainless steel	
0,075 =	250	100	
0,16 =	250	100	
0,32 =	210	100	
0,5 =	210	100	
0,75 =	150 - 210 - 330	100	
1 =	210	100	
1,4 =	210 - 250 - 350	100	
2 =	100 - 250	100	
2,8 =	250 - 350	100	
3,5 =	250 - 350	-	

Special variants on request

Types normally available from stock:

- AMS0.32P210CG4-0-VM/30
- AMS0.5P210CG4-0-VM/30
- AMS0.75P210CG4-0-VM/30

10	Precharge pressure (bar)
Standard 30 bar = 0 ÷ 130 (max 130 bar)	

9	Test and certification
Factory testing	= 0
TR (Russia)	= 1
ML (China)	= 3
PED97/23/EC(for capacity 1,5-2,5 l)	= 8
ATEX 94/9EC	= 9
RTN Passport (Russia)	= 11
Algeria passport	= 12
Standard regulation (NR13) (Brazil)	= 13
Tunisia passport	= 14

8	Gas side connection
Standard filling valve thread M28x1.5	= VM
Without pre-charge valve with fixed pre-charge calibration	= VT

7	Dimension of connection side
For the type of connection:	
G (for capacity 0.075 ÷ 2 l) 1/2"	= 4
G (for capacity 2 ÷ 3.5 l) 3/4"	= 5

6	Fluid port connection
BSP ISO 228 Female	= G
BSP ISO 228 Female and metric male	= W
male M33x1.5 for capacity 0.5-0.75-1-1.4 - 2 l	
male M45x1.5 for capacity 2.8 -3.5	

5	Body material
Carbon steel	= C
Stainless steel (100 bar)	= X

5.3.7 DIMENSIONS

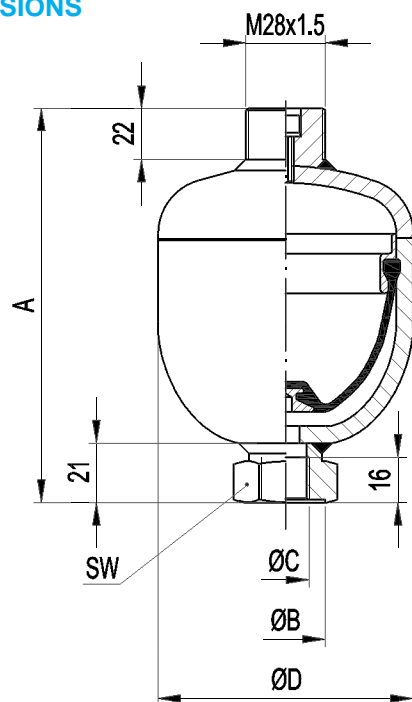


fig. I

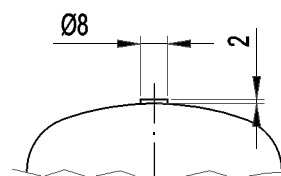


Fig. II

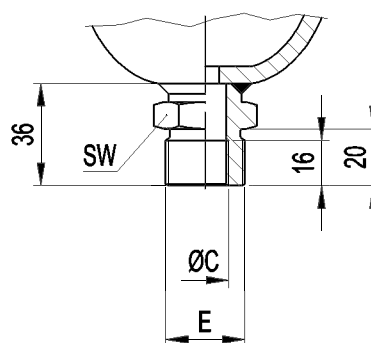


fig. II

5.3d

Accumulator type AMS	Fig.	Nominal gas value litres	Actual gas value litres	Working pressure bar	PED category for the liquids of group 2	Maximum differential pressure* bar	Flow rate** l/min	Maximum compression ratio Po/P2	A mm	Ø B mm	Ø C mm	Ø D mm	E mm	SW mm	Dry weight Kg
AMS 0,075	I - II	0,075	0,075	250	Art.3 (3)	210	20	1 : 8	111	29	1/2"	64	-	32	0,7
AMS 0,16	I - II	0,16	0,16	250	Art.3 (3)	210	20	1 : 8	120	29	1/2"	75	-	32	1
AMS 0,32	I - II	0,32	0,32	210	Art.3 (3)	140	40	1 : 8	140	29	1/2"	93	-	32	1,4
AMS 0,5	I-II-III	0,5	0,5	210	Art.3 (3)	175	50	1 : 8	152	34	1/2"	106	M33x1,5	41	2
AMS 0.75	II-III	0.75	0.75	150	Art.3 (3)	120	50	1 : 8	166	34	1/2"	121	M33x1.5	41	2.6
	210			175		122			2.6						
	330			150		125			4.4						
AMS 1	I-II-III	1	1	210	Art.3 (3)	170	50	1 : 8	180	34	1/2"	136	M33x1.5	41	3.5
AMS 1.4	I-II-III	1.4	1.4	140	I	100	50	1 : 8	199	34	1/2"	150	M33x1.5	41	4.2
				250		120			148			5.4			
				350		150			160			7.4			
AMS 2	I-II-III	2	2	100	I	80	50	1 : 8	213	34	1/2"	163	M33x1.5	41	3.5
				210		120			144			4.2			
				250		140			155			7.5			
				350		200			180			11.3			
AMS 2.8	I-II-III	2.8	2.8	210	II	100	50	1 : 4	213	34	1/2"	163	M33x1.5	41	8.2
				250		140			174			10			
				350		200			180			14.3			
AMS 3.5	I-II	3.5	3.5	250	II	140	70	1 : 4	307	34	3/4"	174	-	41	11
				350		200			180			16			

* The maximum differential pressure is the maximum allowable difference between the maximum pressure and the minimum working pressure (P2-P1) to have an infinite life cycle of the accumulator (greater than 2,000,000 cycles).

** Flow rate measured using mineral oil with viscosity of 36 cSt at 50°C and $\Delta P = 5$ bar

5.3e

5.3.8 EUROPE MARKET

All hydraulic accumulators are pressure vessels and are subject to the national regulations and directives, valid at the place of installation. Diaphragm accumulator type AMS, up to and including 1 litre, must not be CE marked.

For diaphragm accumulator type AMS, greater than 1 litre, every shipping batch is provided with a conformity declaration and use and maintenance instructions and/or all documents requested.

All vessel categories (see Table 5.3e) must be protected by means of a pressure relief valve in accordance with Directive 97/23/EC.

5.3.9 SPARE PARTS CODE

Item	Description	AMS 0.075 ÷ 2,8
1	Gas valve VM	V2220-CP

5.2f

5.3.10 ACCESSORIES

For clamps, see Cap.7

For pre-loading and charging set, see Cap.11.2

For pulse damper adapters, see Cap.12.1

5.3.11 COMMISSIONING AND MAINTENANCE

Delivery condition

Diaphragm accumulators are delivered pre-charged with nitrogen at a pressure of 30 bar or at value of pressure required at time of order.

The pre-charge value is still on the nameplate of the accumulator.

Depending on the size and quantity ordered, the diaphragm accumulators are shipped in boxes or in cartons or on pallets, or wooden boxes on request.

Unless otherwise required, certificates and documentation are provided together with the accumulators.

Handling

The original packaging is suitable for handling and general storage.

Where necessary, you should use suitable lifting equipment to support the weight of the accumulators.

Protect from impact, however, the packaging and handle it with care.

Storage

During storage in the warehouse, leave the product in its original packaging, keeping it away from heat sources and naked flames. The storage temperature should be between +10 and +40°C.

After six years of storage, it is essential to proceed with the replacement of all elastomeric parts before the commissioning.

Marking on the nameplate of the accumulator

With reference to the PED 97/23/EC classification, Article 3, Paragraph 3 and / or risk categories I or II according to the amount and maximum working pressure, the accumulator indicates the following

- logo, name and country of the manufacturer
- product code
- Month / year of production
- Serial number

- Maximum PS pressure and PT test pressure in bar
- Min. and max. TS working temperature in Celsius
- Volume V in litres
- Group of fluids allowed (II)
- CE marking (by volume exceeding 1 litre) with the identification number of the notified body
- Pre-charge pressure in bar

It is strictly forbidden to:

- engrave or permanently stamp the surfaces of the accumulator shell and / or carry out other operations that could affect or change the mechanical properties of the accumulator
- use the accumulator as a structural element: it should not be subjected to stresses or loads
- change the data of the nameplate and / or accumulator without the permission of the manufacturer
- use a (dangerous) fluid of Group 1 with equipment designed and manufactured for fluids of Group 2.

Installation

Before installation, you must perform a visual check to verify that the accumulator has not suffered any damage during shipping / handling. Verify that the requested type matches with what stamped on the nameplate.

We recommend using the accumulator with a suitable safety valve (see section 8) or a security safety block type BS (see section 9). This device provides user and equipment protection against possible damage caused by pressure surges, and also makes the maintenance of the accumulator easier, so facilitating the interception and the discharge.

Provide for a clearance of 200 mm above the gas pre-charge valve to allow access to and control of the pre-charge equipment (see section 11.2).

The accumulators type AMS may be installed in any position from horizontal to vertical (preferably with the pre-charge valve at the top), and the nameplate must be visible.

Proceed to the assembly so that no abnormal force affects the pipes connected directly or indirectly to the accumulator, so we recommend the use of supporting components and also fastening (please see Chapter 7) to avoid the transmission of vibrations.

Make sure the fluid is compatible with the elastomer of the diaphragm. Check that the max. allowed accumulator pressure is equal to or greater than that of the hydraulic circuit and that the temperature during operation is maintained within the range expected.

Make sure the fluid does not contain contaminants and/or abrasive.

Pre-charge of nitrogen

Normally, the diaphragm accumulators are delivered pre-charged with pressurized gas. The pre-charge of gas can be controlled and / or adjusted before or after installation of the accumulator in the hydraulic circuit. For the pre-charge, use only industrial dry nitrogen with a purity of min. 99%. It is important to use the nitrogen from a cylinder equipped with a pressure reducing valve (see Chap.11.3). Use the EPE pre-charge and charging set type PCM to check the charging pressure Calculated Against the pressure, and adjust if necessary.

If the pre-charge pressure is lower than required, connect the inflation tube on one side and the other of the equipment. Connect it to the cylinder of nitrogen or to the pressure reducer. Slowly enter the nitrogen in the accumulator until reaching a pressure slightly higher than that

set (+ 10 ÷ 15%).

Close the cylinder and remove the connecting pipe from the equipment; wait until the gas temperature has stabilized (1 hour) and calibrate the pressure, discharging the excess gas. Make sure that the gas pipe is not subject to losses and, if necessary, use soap and water.

Hydraulic pressurization

- Check that the pre-charge pressure is adequate for the application
- Ensure that the hydraulic pressure never exceeds the max. (PS) allowed and shown on the accumulator shell.

To avoid this risk, use a safety item (see Chap. 9).

Maintenance

- Periodically check the pre-charge pressure of the gas: after the commissioning, check after 2-3 weeks of operation and if there were no leaks, repeat the operation after 3 months; if the pressure at the same temperature was stable, repeat the test at annual intervals. For heavy-duty applications, check the pre-charge every 6 months.
- Periodically (annually) carry out a visual inspection of the accumulator in order to detect any early signs of deterioration such as corrosion, deformation, etc.
- Comply with the requirements of the regulations concerning the verification of the functionality of the equipment according to the country of installation of the accumulator.

Disassembly

If for failure, scheduled check or retest it is necessary to remove the accumulator from the system, prior to removal, isolate the accumulator from the installation and discharge pressure of the liquid.

All diaphragm EPE accumulators of the AMS series may be repaired.

- Fix the accumulator.
- Remove the pre-charge valve (after having discharged completely the nitrogen).

Repair

It may consist in replacing the pre-charge valve. For reasons of functionality and security, it is recommended to use only original spare parts.

Before starting the repair, drain completely the nitrogen contained in the accumulator.

Refitting

After thorough cleaning, check and replace the pre-charge valve.

Pre-charge

- Screw the pre-charge PCM equipment on the gas valve.
- Connect the equipment to the cylinder of nitrogen or to the pressure reducer with the inflation tube.
- Slowly enter the nitrogen in the accumulator until reaching a pressure slightly higher than the set value (+ 10 ÷ 15%).
- Close the cylinder and remove the connecting pipe from the equipment.
- Wait until the gas temperature has stabilized (1 hour).
- Calibrate the pressure discharging the excess gas.

Demolition and recycling of the accumulator

Before accumulator demolition or recycling, you should always discharge completely the pre-charge pressure and remove the gas valve.

If you need, proceed decontaminating in relation to the fluid used prior to demolition.

Reproduction Is Forbidden.

In The Spirit Of Continuous Improvement, Our Products May Be Changed.



ADDITIONAL BOTTLES type B

6.1



ADDITIONAL BOTTLES type ASS

6.2



ADDITIONAL BOTTLES type ASSA

6.3



ADDITIONAL BOTTLES type AB

6.4

6.1.1 TECHNICAL DATA

MAX OPERATING PRESSURE (PS): 360 bar

PRESSURE TEST (PT): 1.43 x PS

NOMINAL CAPACITIES: 52 - 75 litres

WORKING TEMPERATURE: -40 ÷ +150 °C

BODY MATERIAL: - carbon steel shell painted with rust inhibitor RAL 8012
- nickel coating 25 - 40 µ

FLUID PORT CONNECTION: 3/4" BSP ISO 228 and
1" BSP ISO 228

WEIGHT: see Table 6.1c

6.1.2 DESCRIPTION

Additional bottles type B consist of a seamless cylindrical pressure vessel made of high-tensile steel. They have one connection of 3/4" BSP ISO 228 and one of 1" BSP ISO 228.

The additional bottles are used to take in and store nitrogen to increase the gas volume in the accumulator station (with bladder or piston accumulator). This means that smaller accumulators can be used for the same gas volume and costs can be reduced. EPE offers a wide selection of bottles type, such as forged "B" version, shell of bladder accumulator "ASS" and "ASSA" versions or body piston type "AB" version.

6.1.3 "B" ADDITIONAL CYLINDERS ADVANTAGES

- compact
- simple construction
- quick, easy installation
- low cost

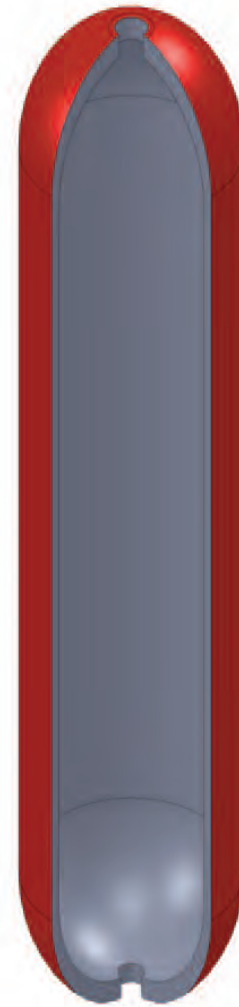
6.1.4 EUROPE MARKET

All hydraulic cylinders are pressure vessels and are subject to the national regulations and directives valid at the place of installation. For additional bottles type B, every shipping batch is complete of a conformity declaration and instructions of use and maintenance and/or all documents requested.

All vessel categories (see Table 6.1c) must be protected by means of a pressure relief valve in accordance with Directive 97/23/EC.

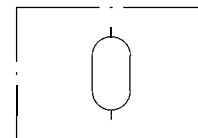
6.1.5 ACCESSORIES

- For support equipment, see section 7
- For gas side's safety equipment, see section 8
- For pre-loading and charging set, see section 11
- For other components, see section 12



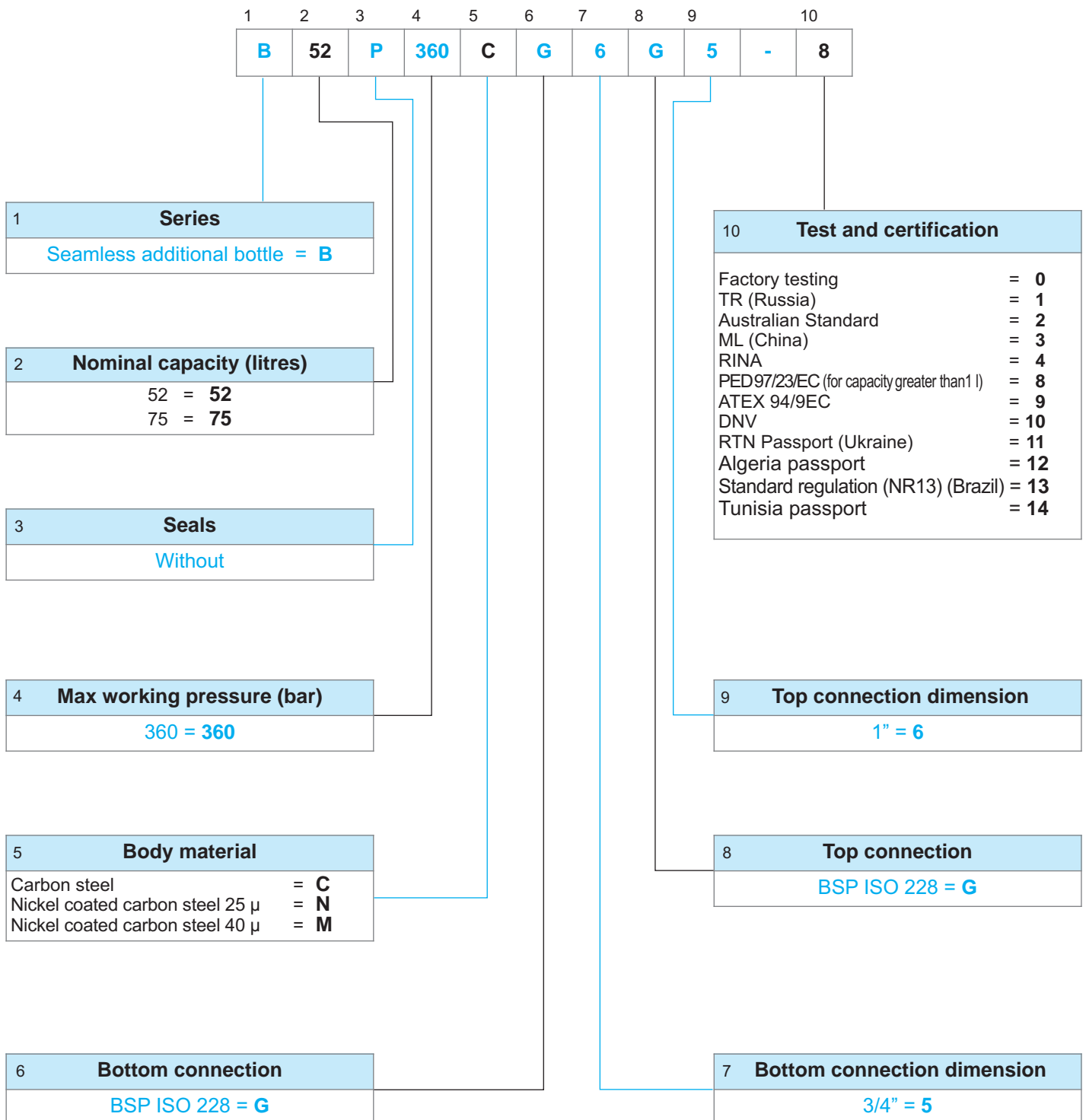
6.1a

6.1.6 HYDRAULIC SYMBOL

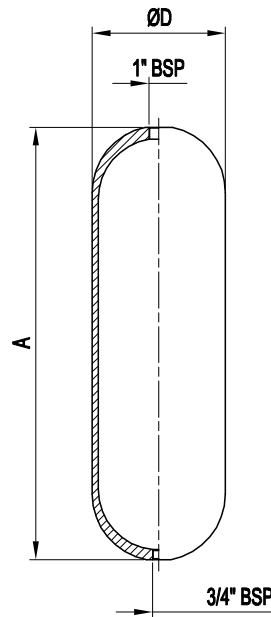


6.1b

6.1.7 ORDER CODE



6.1.8 DIMENSIONS



Additional bottle type B in carbon steel	Nominal gas volume litres	Effective gas volume litres	Working pressure bar	Ped category for the liquids of group 2	Maximum differential pressure bar	A mm	ØD mm	Dry weight kg
B52	52	50	360	IV	100	1722± 10	220	93,5
B75	75	75	360	IV	100	2520± 10	220	135

6.1c

* The maximum differential pressure is the maximum allowable difference between the maximum pressure and the minimum working pressure (P2-P1) to have an infinite life cycle of the accumulator (greater than 2,000,000 cycles).

6.1.9 COMMISSIONING AND MAINTENANCE

Delivery condition

The additional bottles type B are shipped on pallets or wooden boxes upon request. Unless otherwise required, certificates and documentation are provided together with the bottles.

Handling

The original packaging is suitable for handling and storage. Where necessary, you should use suitable lifting equipment to support the weight of the bottles. However protect from impact the packaging and handle it with care.

Storage

During storage in the warehouse, leave the product in its original packaging, keeping it away from heat sources and naked flames. The storage temperature should be between +10 and +40°C.

Marking of the cylinder body

With reference to the PED 97/23/EC classification, Article 3, Paragraph 3 and / or risk categories I or IV depending on to the volume and maximum working pressure, the cylinder indicates the following data:

- logo and country of the manufacturer
- month / year of production
- product code
- serial number
- maximum PS pressure and PT test pressure in bar
- min. and max. TS working temperature in Celsius
- volume V in litres
- group of fluids allowed
- CE marking with the identification number of the notified body

It is strictly forbidden to:

- weld, rivet or screw any item of the cylinder
- engrave or permanently stamp the surfaces of the cylinder shell and / or carry out other operations that could affect or change the mechanical properties of the cylinder
- use the cylinder as a structural element: it should not be subjected to stresses or loads
- change the data of the nameplate without the permission of the manufacturer
- use a (dangerous) fluid of Group 1 with equipment designed and manufactured for fluids of Group 2.

Installation

Before installation, you must perform a visual check to verify that the bottles has not suffered any damage during shipping / handling.

Verify that the requested type matches with what stamped on the nameplate.

We recommend using the additional bottles connected to the accumulator with a suitable safety valve (see Chapter 8).

This device provides the user and equipment protection against damage caused by pressure peaks.

The additional bottles type B may be installed in any position from horizontal to vertical (preferably with the connections vertically) and the data must be visible.

Proceed to the assembly so that no abnormal force affects the pipes connected directly or indirectly to the additional bottles, so we recommend

the use of supporting components and also fastening (please see Chapter 7) to avoid the transmission of vibrations.

Make sure that the cylinder is connected to the circuit through suitable connection devices.

Check that the max. allowed bottles pressure is equal to or greater than that of the circuit and that the temperature during operation is maintained within the range expected.

Make sure the fluid does not contain contaminants.

Maintenance

- Periodically check the pre-charge pressure of the system: after the commissioning, check after 2-3 weeks of operation and if there were no leaks, repeat the operation after 3 months; if the pressure at the same temperature was stable, repeat the test yearly. For heavyduty applications, check the pre-charge every 6 months.
- Periodically (yearly) carry out a visual inspection of the bottle in order to detect any early signs of deterioration such as corrosion, deformation, etc.
- Comply with the requirements of the regulations concerning the verification of the functionality of the equipment according to the country of installation of the bottle.

Disassembly

If for failure, scheduled check or retest it is necessary to remove the additional bottle from the system, prior to removal, completely discharge the pressure within the circuit.

Demolition and recycling of the additional cylinder

Before demolition or recycling of the additional cylinder, you should always discharge the internal pressure.

If needed, proceed decontaminating in relation to the gas/fluid used prior to demolition.

Reproduction Is Forbidden.

In The Spirit Of Continuous Improvement, Our Products May Be Changed.

6.2.1 TECHNICAL DATA

MAX OPERATING PRESSURE (PS): 360 bar

PRESSURE TEST (PT): 1.43 x PS

NOMINAL CAPACITIES: 3 - 5 - 10 - 15 - 20 - 25 - 35 - 55 litres

WORKING TEMPERATURE: -40 ÷ +150 °C

BODY MATERIAL- carbon steel shell painted with rust inhibitor RAL 8012
 - nickel coating 25 - 40 µ
 - internal and external coating with RILSAN th. 0.6 mm

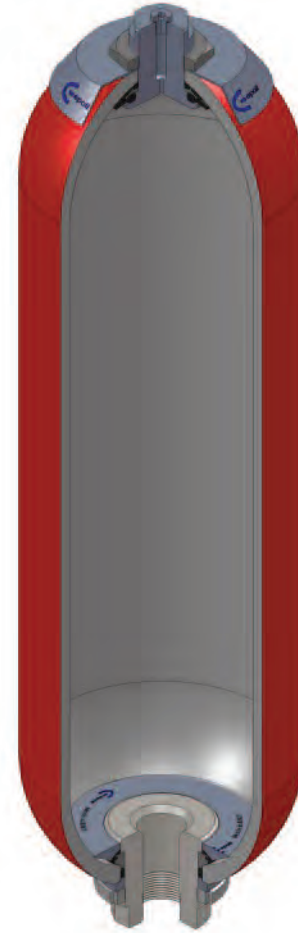
VALVES MATERIAL: - phosphated or
 - galvanized carbon steel in compliance with Directive 2002/95/EC (RoHS) to resist to corrosion
 - stainless steel AISI 316L
 - nickel coating 25-40 µ

SEALS MATERIAL: - P = Nitrile rubber (NBR)
 - F = Low temp. nitrile rubber
 - H = Nitrile for hydrocarbons
 - K = Hydrogenated nitrile (HNBR)
 - B = Butyl (IIR)
 - E = Ethylene-propylene (EPDM)
 - N = Chloroprene (Neoprene)
 - Y = Epichlorohydrin (ECO)
 - V = Fluorocarbon (FPM)

See Table 6.2c and/or Chapter 1.5

CONNECTIONS: see Table 6.2db - 6.2dc - 6.2df

WEIGHT: see Table 6.2db- 6.2df



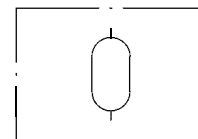
6.2a

6.2.2 DESCRIPTION

Additional bottles type ASS consist of a seamless cylindrical pressure vessel made of high-tensile steel.

They are derived from the same shells of the AS bladder accumulator. The additional bottles are used to take in and store nitrogen to increase the gas volume in the accumulator station (with bladder or piston accumulator). This means that smaller accumulators can be used for the same gas volume and costs can be reduced. EPE offers a wide selection of bottles type, such as forged "B" version, shell of bladder accumulator "ASS" and "ASSA" versions or body piston type "AB" version.

6.2.4 HYDRAULIC SYMBOL



6.2b

6.2.3 "ASS" ADDITIONAL CYLINDERS ADVANTAGES

- compact
- simple construction
- wide range of small-medium capacity
- works well on water, low lubricity fluids
- quick, easy installation

6.2.5 SEALS-TEMPERATURE-LIQUID COMPATIBILITY

When selecting the additional cylinder variant, pay attention to the following non-binding notes with regard to hydraulic fluid, seals material and the permissive temperature range. (see Section)

Code letter	Polymer	ISO	Temperature range (°C)	Some of the liquids compatible with the polymer
P	Standard nitrile (Perburan)	NBR	-20 ÷ +80	Aliphatic hydrocarbons (propane, butane, gasoline, oils, mineral greases, diesel fuel, fuel oil, kerosene), mineral greases and oils, HFA - HFB - HFC fluids, many dilute acids, alkalis, saline solutions, water, water glycol.
F	Low temperature nitrile	NBR	-40 ÷ +70	The same as with standard nitrile + a number of different types of Freon. (This contains less acrylonitrile than the standard and is therefore more suitable for low temperatures, but its chemical resistance is slightly lower).
H	Nitrile for hydrocarbons	NBR	-10 ÷ +90	Regular and premium grade slightly aromatic gasoline (and all the liquids for standard nitrile).
K	Hydrogenated nitrile	HNBR	-30 ÷ +130	The same as with standard nitrile but with excellent performance at high and low temperatures.
B	Butyl	IIR	-30 ÷ +100	Hot water up to 100°C, glycol-based brake fluids, many acids and bases, salt solutions, polar solvents such as alcohols, ketones and esters, polyglycol-based hydraulic fluids (HFC fluids) and bases of esters of phosphoric acid (HFD-R fluids), silicone oils and greases, Skydol 500 and 7000, resistance to ozone, aging and weathering.
E	Ethylene-Propylene	EPDM	-30 ÷ +100	Hot water up to 100°C, glycol-based brake fluids, many organic and inorganic acids, detergents, solutions of sodium and potassium, phosphate ester-based hydraulic fluids, (HFD-R), silicone oils and greases, many polar solvents (alcohol, ketones, esters), Skydol 500 and 7000, resistance to ozone, aging and weathering.
N	Chloroprene (Neoprene)	CR	-30 ÷ +100	Mineral oils of paraffin, silicone oils and greases, water and aqueous solutions, refrigerants (ammonia, carbon dioxide, Freon), naphthenic mineral oils, low molecular aliphatic hydrocarbons (propane, butane, fuel), brake fluids based on glycol, better resistance to ozone, weathering and aging compared to NBR rubber.
Y	Epichloridrin	ECO	-30 ÷ +110	Mineral oils and greases, aliphatic hydrocarbons (propane, butane and gasoline), silicone oils and greases, water at room temperature, resistance to ozone, aging and weathering.
V	Fluorocarbon	FPM	-10 ÷ +150	Mineral oils and greases, non-flammable fluids of HFD group, silicone oils and greases, animal and vegetable oils and greases, aliphatic hydrocarbons (gasoline, butane, propane, natural gas), aromatics hydrocarbons (benzene, toluene), chlorinated hydrocarbons (Tetrachloroethylene, carbon tetrachloride), fuel (regular, super and containing methanol), excellent resistance to ozone, weathering and aging.

For other hydraulic fluid and/or temperatures, please consult us.

6.2c

6.2.6 ORDER CODE

1	2	3	4	5	6	7	8	9
ASS	25	P	360	C	G	5	VT	- 8

1	Series
	Additional bottle = ASS

2	Nominal capacity (litres)
	3 = 3
	5 = 5
	10 = 10
	15 = 15
	20 = 20
	25 = 25
	35 = 35
	52 = 52

3	Seals material material
	Nitrile rubber (NBR) = P
	Nitrile for low temp. = F
	Nitril for hydrocarbons = H
	Hydrogenated nitrile (HNBR) = K
	Butyl (IIR) = B
	Ethylene-propylene (EPDM) = E
	Chloroprene (Neoprene) = N
	Epichlorohydrin (ECO) = Y
	Fluorocarbon (FPM) = V

4	Max working pressure (PS)
Capacity litres	Carbon steel
3 ÷ 55	360
	210 only for the version with connection L

5	Body material
	Carbon steel = C
	Nickel coated carbon steel 25 μ = N
	Nickel coated carbon steel 40 μ = M
	Rilsan coating = V

6	Bottom connection
	BSP ISO 228 (std) = G
	adapter for flange SAE 3000 Psi = L
	adapter for flange SAE 6000 Psi = H

9	Test and certification
	Factory testing = 0
	TR (Russia) = 1
	Australian Standard = 2
	ML (China) = 3
	RINA = 4
	PED97/23/EC (for capacity greater than 1 l) = 8
	ATEX 94/9EC = 9
	DNV = 10
	RTN Passport (Ukraine) = 11
	Algeria passport = 12
	Standard regulation (NR13) (Brazil) = 13
	Tunisia passport = 14

8	Top connection
	Thread hole M12x1.5 plugged = VT
	1/4" BSP ISO 228 = G2
	1/2" BSP ISO 228 = G4
	3/4" BSP ISO 228 = G5
	1" BSP ISO 228 = G6
	1"1/4 BSP ISO 228 = G7
	1"1/2 BSP ISO 228 = G8

7	Bottom connection dimension
	For the type of connection:
	G 3/4" BSP ISO 228 = 5
	1" BSP ISO 228 = 6
	1"1/4 BSP ISO 228 = 7
	1"1/2 BSP ISO 228 = 8
	L (3÷5 l) 1" 1/4 SAE3000 = 7
	(10÷55 l) 1" 1/2 SAE 3000 = 8
	2" SAE 3000 = 9
	H (3÷5 l) 1" 1/4 SAE6000 = 7
	(10÷55 l) 1" 1/2 SAE 6000 = 8
	2" SAE 6000 = 9
	Special variants upon request

6.2.7 DIMENSIONS

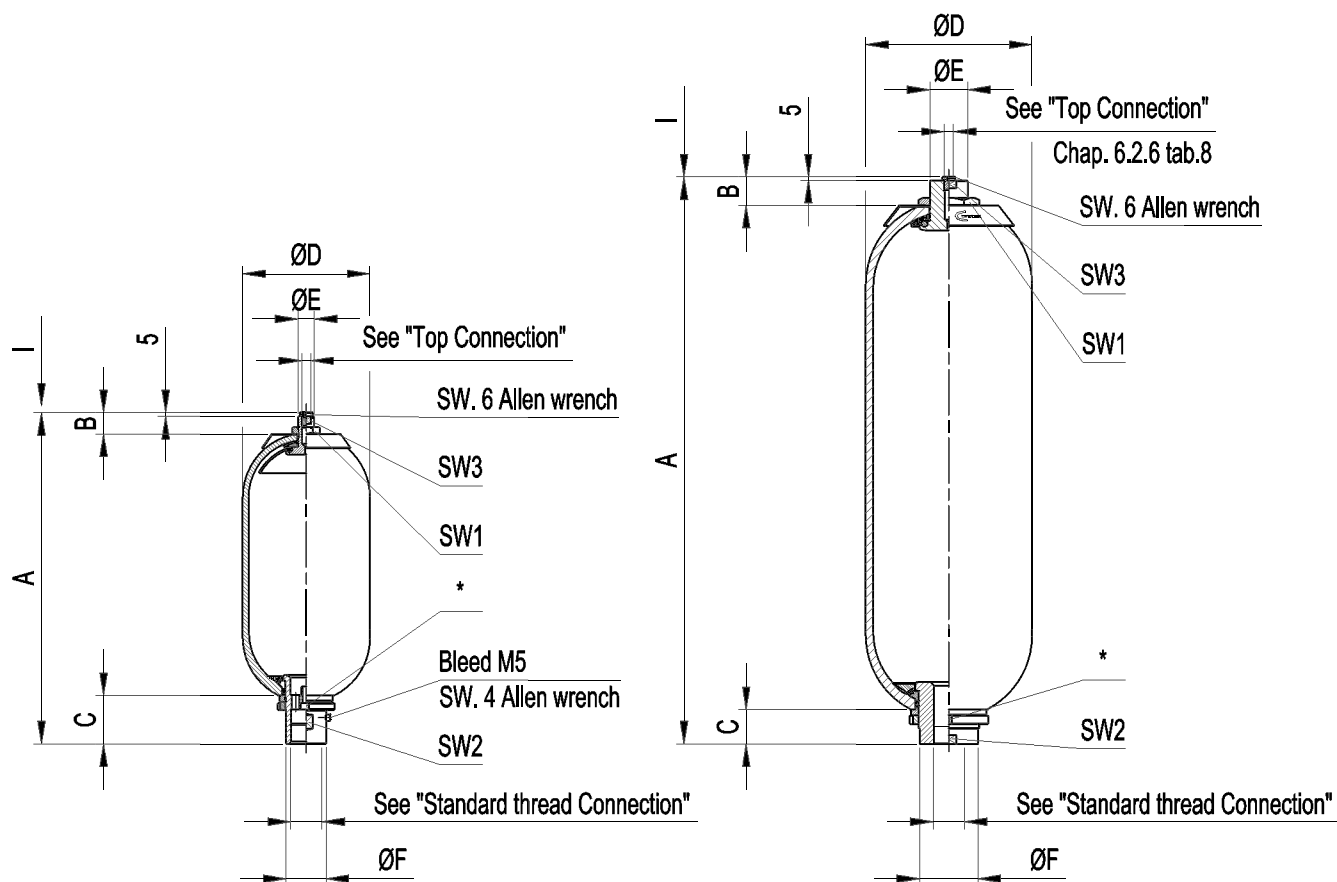


Fig. I

Fig. II

6.2da

Acc. type ASS in carbon steel	Nominal gas volume litres	Working pressure bar	Ped. cat. fluids of group 2 AS	Fig.	A mm	B mm	C mm	ØD mm	ØE mm	ØF mm	I mm	SW 1 mm	SW 2 mm	SW 3 mm	Acc. dry weight kg
ASS 3	3	360	III	I	534 ± 8	28	65	114	M22x1,5	53	140	32	50	18	8
ASS 5	5	360	III	I	438 ± 10	28	65	168	M22x1,5	53	140	32	50	18	13
ASS 10	10	360	IV	II	500 ± 10	35	55	220	M50x1,5	77	140	70	70	41	31
ASS 15	15	360	IV	II	650 ± 10	35	55	220	M50x1,5	77	140	70	70	41	41
ASS 20	20	360	IV	II	810 ± 10	35	55	220	M50x1,5	77	140	70	70	41	45
ASS 25	25	360	IV	II	975 ± 15	35	55	220	M50x1,5	77	140	70	70	41	56
ASS 35	35	360	IV	II	1325 ± 15	35	55	220	M50x1,5	77	140	70	70	41	74
ASS 55	55	360	IV	II	1835 ± 15	35	55	220	M50x1,5	77	140	70	70	41	102

* see chapter 6.2.11 table 6.2dh

6.2db

- The maximum differential pressure is the maximum allowable difference between the maximum pressure and the minimum working pressure (P2-P1) to have an infinite life cycle of the accumulator (greater than 2,000,000 cycles).

- Flow rate measured using mineral oil with viscosity of 36 cSt at 50°C and ΔP = 5 bar

6.2.7.1 STANDARD THREAD CONNECTIONS

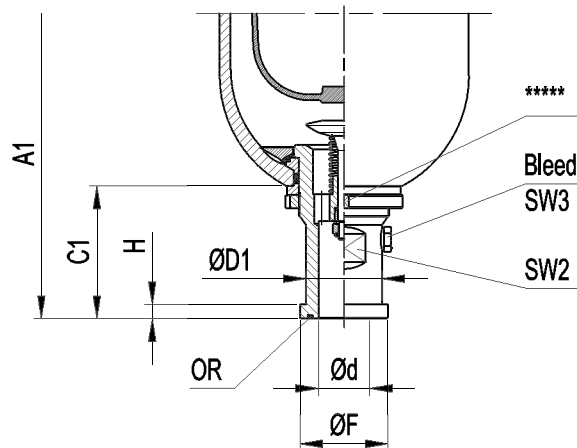
Dimensions	Connection Type	Accumulator type	Complete spare valve order code	Ød	ØD mm	ØF mm	H mm	
	G	ASS 3	V 2250-G7-***	1" 1/4 BSP	-	53	25	
		ASS 5	V 2253-G7-***					
		BSP ISO 228	ASS 10 + 55	V 2267-G5-***	3/4" BSP	-	77	20
				V 2267-G6-***	1" BSP	-	77	22
				V 2267-G7-***	1" 1/4 BSP	-	77	25
				V 2267-G8-***	1" 1/2 BSP	-	77	25

* Gasket material

** Components material

6.2dc

6.2.7.2 ADAPTER FOR FLANGE SAE 3000/6000 PSI (L/H)



6.2de

Acc. type ASS in carbon steel	Dim.	A1 mm	C1 mm	SW2 mm	SW3 mm	Bleed	Ød mm	SAE 3000 (L)				SAE6000 (H)				OR	Acc. dry weight kg
								Spare valve order code	ØD1 mm	ØF mm	H mm	Spare valve order code	ØD1 mm	ØF mm	H mm		
ASS 3	1"	589 ± 8	100	38	4***	M5	-	-	-	-	-	V 2025-H6-***	38	47,6	9,5	0010R4131-*	11
	1" 1/4	578 ± 8	89				31	V 2025-L7-***	43	50,8	8	V 2025-H7-***	44	53,3	10,3	0010R4150-*	
ASS 5	1"	493 ± 10	100	38	4***	M5	-	-	-	-	-	V 2044-H6-***	38	47,6	9,5	0010R4131-*	15
	1" 1/4	482 ± 10	89				31	V 2044-L7-***	43	50,8	8	V 2044-H7-***	44	53,3	10,3	0010R4150-*	
ASS 10	1" 1/2	583 ± 10	115	42	19****	1/4"	32	V 2064-L8-***	50	60,3	8	V 2064-H8-***	51	63,5	12,5	0010R4187-*	33
	2"			55		BSP	45	V 2064-L9-***	62	71,5	9,5	V 2064-H9-***	67	77,6		0010R4225-*	
ASS 15	1" 1/2	733 ± 10	115	42	19****	1/4"	32	V 2064-L8-***	50	60,3	8	V 2064-H8-***	51	63,5	12,5	0010R4187-*	43
	2"			55		BSP	45	V 2064-L9-***	62	71,5	9,5	V 2064-H9-***	67	77,6		0010R4225-*	
ASS 20	1" 1/2	893 ± 10	115	42	19****	1/4"	32	V 2064-L8-***	50	60,3	8	V 2064-H8-***	51	63,5	12,5	0010R4187-*	48
	2"			55		BSP	45	V 2064-L9-***	62	71,5	9,5	V 2064-H9-***	67	77,6		0010R4225-*	
ASS 25	1" 1/2	1058 ± 15	115	42	19****	1/4"	32	V 2064-L8-***	50	60,3	8	V 2064-H8-***	51	63,5	12,5	0010R4187-*	59
	2"			55		BSP	45	V 2064-L9-***	62	71,5	9,5	V 2064-H9-***	67	77,6		0010R4225-*	
ASS 35	1" 1/2	1408 ± 15	115	42	19****	1/4"	32	V 2064-L8-***	50	60,3	8	V 2064-H8-***	51	63,5	12,5	0010R4187-*	78
	2"			55		BSP	45	V 2064-L9-***	62	71,5	9,5	V 2064-H9-***	67	77,6		0010R4225-*	
ASS 55	1" 1/2	1918 ± 15	115	42	19****	1/4"	32	V 2064-L8-***	50	60,3	8	V 2064-H8-***	51	63,5	12,5	0010R4187-*	108
	2"			55		BSP	45	V 2064-L9-***	62	71,5	9,5	V 2064-H9-***	67	77,6		0010R4225-*	

* Gasket material

** Components material

*** Allen wrench

**** Ex. Wrench

***** see chapter 6.2.11 table 6.2dh

6.2df

6.2.8 SPARE PARTS CODE (STANDARD VERSION)

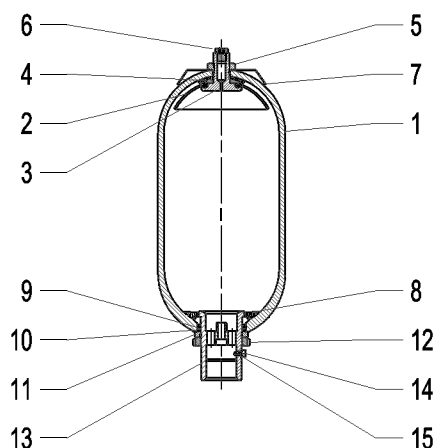


Fig. I

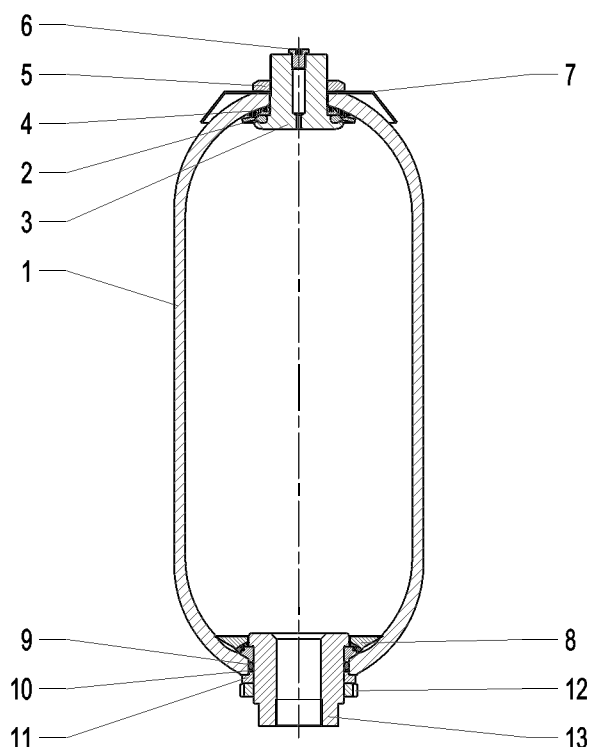


Fig. II

6.2dg

Item	Description	Q.ty	Type		
			ASS 3 (Fig. I)	ASS 5 (Fig. I)	ASS 10 + 55 (Fig. II)
1	Accumulator shell	1	Not supplied as spare part		
2	Seal gas side	1	B11250 - *	B11252 - *	B10052 - *
3	Gas valve body	1	B10107 - **	B10202 - **	B10333 - **
4	Rubber-coated washer	1	B10106 - ** / *	B10205 - ** / *	B10334 - ** / *
5	Gas valve looknut	1	B10109 - **		B10302 - **
6	Plug	1	B10043 - **		
7	Name plate	1	D10300B-A	D10300C-A	D10300D-A
8	Retaining ring	1	B10146 - ** / *	B10222 - ** / *	B10317 - ** / *
9	"O" ring	1	0010R0159 - *	0010R6212 - *	0010R0181 - *
10	Supporting ring	1	B10150-T	B10227-T	B10320-T
11	Space ring	1	B10223 - **		B10319 - **
12	Fluid port ring nut	1	B10217 - **		B10321 - **
13	Fluid port body	1	B10144 - *** - **		B10311 - *** - **
14	Bleed screw ****	1	B10128 - **		-
15	Seal ring ****	1	B10129-R		-
	Standard gas valve ass. (parts 2 + 6)	1	V 2033 - ** / *	V 2049 - ** / *	V 2270 - ** / *
	Standard fluid port ass. (parts 8 ÷ 15)	1	V 2250 - *** - ** / *	V 2253 - *** - ** / *	V 2267 - *** - ** / *
	Gasket sets	1	B2031-1- [*] { B11250- [*] 0010R0159- [*] B10150-T	B2050-1- [*] { B11525- [*] 0010R6212- [*] B10227-T	B2080-1- [*] { B10062- [*] 0010R0181- [*] B10320-T

* Gasket material

** Component material

*** See chapter 6.2.6 table 8 - 9

6.2dh

**** Only for Fig. I

6.2.9 EUROPE MARKET

All hydraulic additional bottles are pressure vessels and are subject to the national regulations and directives valid at the place of installation. For additional cylinders type ASS, every shipping batch is complete of a conformity declaration and instructions of use and. All vessel categories (see Table 6.2d) must be protected by means of a pressure relief valve in accordance with Directive 97/23/EC.

6.2.10 ACCESSORIES

For support equipment, see section 7
 For gas side's safety equipment, see section 8
 For pre-loading and charging set, see section 11
 For other components, see section 12

6.2.11 COMMISSIONING AND MAINTENANCE

Delivery condition.

Depending on the size and quantity ordered, the additional bottles are shipped in cartons or in cartons on pallets, or wooden boxes upon request. Unless otherwise required, certificates and documentation are provided together with the bottles.

Handling

The original packaging is suitable for handling and storage. Where necessary, you should use suitable lifting equipment to support the weight of the bottles. However protect from impact the packaging and handle it with care.

Storage

During storage in the warehouse, leave the product in its original packaging, keeping it away from heat sources and naked flames. The storage temperature should be between +10 and +40°C. After six years of storage, it is essential to proceed with the replacement of all elastomeric parts before the commissioning.

Marking on the nameplate of the additional cylinder.

With reference to the PED 97/23/EC classification, Article 3, Paragraph 3 and / or risk categories I or IV depending on volume and maximum working pressure, the cylinder indicates the following data:

- logo, name and country of the manufacturer
- month / year of production
- product code
- serial number
- maximum PS pressure and PT test pressure in bar
- min. and max. TS working temperature in Celsius
- volume V in litres
- group of fluids allowed
- CE marking (by category I ÷ IV) with the identification number of the notified body

It is strictly forbidden to:

- weld, rivet, bolt or screw any item of the cylinder shell
- engrave or permanently stamp the surfaces of the cylinder shell and / or carry out other operations that could affect or change the mechanical properties of the cylinder
- use the cylinder as a structural element: it should not be subjected to stresses or loads

- change the data of the nameplate and / or the cylinder without the permission of the manufacturer
- use a (dangerous) fluid of Group 1 with equipment designed and manufactured for fluids of Group 2.

Installation

Before installation, you must perform a visual check to verify that the bottles has not suffered any damage during shipping / handling. Verify that the requested type matches with what stamped on the nameplate.

We recommend using the additional bottles connected to the accumulator with a suitable safety valve (see Chapter 8).

This device provides user and equipment protection against possible damages due to pressure peaks.

The additional bottles type ASS may be installed in any position from horizontal to vertical (preferably with the connections vertically) and the nameplate must be visible.

Proceed to the assembly so that no abnormal force affects the pipes connected directly or indirectly to the additional bottles, so we recommend the use of supporting components and also fastening (please see Chapter 7) to avoid the transmission of vibrations.

Make sure that the bottle is connected to the hydraulic circuit through suitable connection devices.

Make sure the gas is compatible with the elastomer of the seals.

Check that the max. allowed bottle pressure is equal to or greater than that of the hydraulic circuit and that the temperature during operation is maintained within the range expected.

Make sure the fluid does not contain contaminants.

Maintenance

- Periodically check the pre-charge pressure of the system: after the commissioning, check after 2-3 weeks of operation and if there were no leaks, repeat the operation after 3 months; if the pressure at the same temperature was stable, repeat the test yearly. For heavy-duty applications, check the pre-charge every 6 months.
- Periodically (yearly) carry out a visual inspection of the bottle in order to detect any early signs of deterioration such as corrosion, deformation, etc.
- Comply with the requirements of the regulations concerning the verification of the functionality of the equipment according to the country of installation of the bottle.

Disassembly

If for failure, scheduled check or retest it is necessary to remove the additional bottle from the system, prior to removal, completely discharge the pressure within the circuit.

All additional EPE bottles of the ASS series can be repaired.

Repair

It can consist in replacing the seals and/or parts of the valves.

For reasons of functionality and security, it is recommended to use only original spare parts.

Demolition and recycling of the additional cylinder

Before demolition or recycling of the additional bottle, you should always discharge the internal pressure.

If needed, proceed decontaminating in relation to the gas/fluid used prior to demolition.

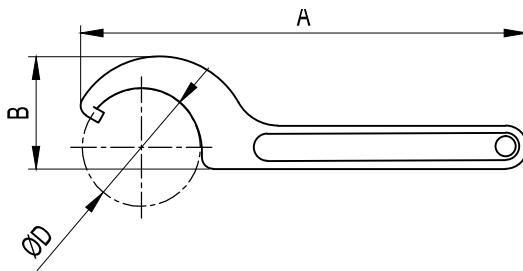
6.2.12 SPANNER WRENCH

Fits all standard size additional bottle type ASS, it is used to remove or install lock nut on fluid port assembly.

3÷5 lt code 2506/68

10÷55 lt code 2506/105

Dimension



CODE	A	B	ØD	For Accumulator
B2506/58	241	45	58	0.7 ÷ 1.5
B2506/68	241	43	68	3 ÷ 5
B2506/105	336	82	105	10 ÷ 55

6.2di

Reproduction is forbidden.

In the spirit of continuous improvement, our products may be changed.

6.3.1 TECHNICAL DATA

MAX OPERATING PRESSURE (PS): 4000 PSI

PRESSURE TEST (PT): 1.5 x PS

NOMINAL CAPACITIES: 1/4 - 1 - 2.5 - 5 - 10 - 15 gallons

WORKING TEMPERATURE: -40 ÷ +200 °F (-40 ÷ +93 °C)

BODY MATERIAL:

- carbon steel shell (SA 372 grade E class 70)
painted with rust inhibitor RAL 8012
- nickel coating 25 - 40 μ
- internal and external coating with RILSAN th. 0.6 mm

VALVES MATERIAL:-

- phosphated or
- galvanized carbon steel in compliance with Directive 2002/95/EC (RoHS) to resist to corrosion
- stainless steel AISI 316L
- nickel coating 25-40 μ

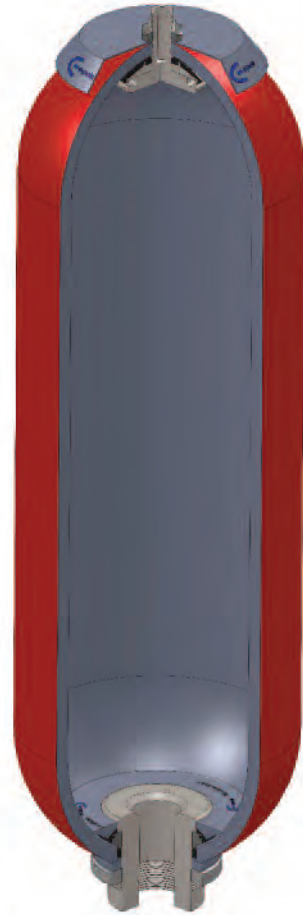
SEALS MATERIAL:-

- P = Nitrile rubber (NBR)
- F = Low temp. nitrile rubber
- H = Nitrile for hydrocarbons
- K = Hydrogenated nitrile (HNBR)
- B = Butyl (IIR)
- E = Ethylene-propylene (EPDM)
- N = Chloroprene (Neoprene)
- Y = Epichlorohydrin (ECO)
- V = Fluorocarbon (FPM)

See Table 3.1c and/or Chapter 6.2.5

CONNECTIONS: see Table 6.2db - 6.2dc - 6.2df

WEIGHT: see Table 6.2db - 6.2df



6.3a

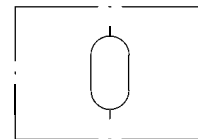
6.3.2 DESCRIPTION

Additional bottles type ASSA consist of a seamless cylindrical pressure vessel made of high-tensile steel.

They are derived from the same shells of the bladder accumulator type ASSA.

The additional bottles are used to take in and store nitrogen to increase the gas volume in the accumulator station (with bladder or piston accumulator). This means that smaller accumulators can be used for the same gas volume and costs can be reduced. EPE offers a wide selection of bottles type, such as forged "B" version, shell of bladder accumulator "ASS" and "ASSA" versions or body piston type "AB" version.

6.3.4 HYDRAULIC SYMBOL



6.3b

6.3.3 "ASSA" ADDITIONAL CYLINDERS ADVANTAGES

- compact
- simple construction
- wide range of small-medium capacity
- works well on water, low lubricity fluids
- quick, easy installation

6.3.5 SEALS-TEMPERATURE-LIQUID COMPATIBILITY

When selecting the additional cylinder variant, pay attention to the following non-binding notes with regard to hydraulic fluid, seals material and the permissive temperature range. (see Section)

Code letter	Polymer	ISO	Temperature range (°C)	Some of the liquids compatible with the polymer
P	Standard nitrile (Perburan)	NBR	-20 ÷ +80	Aliphatic hydrocarbons (propane, butane, gasoline, oils, mineral greases, diesel fuel, fuel oil, kerosene), mineral greases and oils, HFA - HFB - HFC fluids, many dilute acids, alkalis, saline solutions, water, water glycol.
F	Low temperature nitrile	NBR	-40 ÷ +70	The same as with standard nitrile + a number of different types of Freon. (This contains less acrylonitrile than the standard and is therefore more suitable for low temperatures, but its chemical resistance is slightly lower).
H	Nitrile for hydrocarbons	NBR	-10 ÷ +90	Regular and premium grade slightly aromatic gasoline (and all the liquids for standard nitrile).
K	Hydrogenated nitrile	HNBR	-30 ÷ +130	The same as with standard nitrile but with excellent performance at high and low temperatures.
B	Butyl	IIR	-30 ÷ +100	Hot water up to 100°C, glycol-based brake fluids, many acids and bases, salt solutions, polar solvents such as alcohols, ketones and esters, polyglycol-based hydraulic fluids (HFC fluids) and bases of esters of phosphoric acid (HFD-R fluids), silicone oils and greases, Skydol 500 and 7000, resistance to ozone, aging and weathering.
E	Ethylene-Propylene	EPDM	-30 ÷ +100	Hot water up to 100°C, glycol-based brake fluids, many organic and inorganic acids, detergents, solutions of sodium and potassium, phosphate ester-based hydraulic fluids, (HFD-R), silicone oils and greases, many polar solvents (alcohol, ketones, esters), Skydol 500 and 7000, resistance to ozone, aging and weathering.
N	Chloroprene (Neoprene)	CR	-30 ÷ +100	Mineral oils of paraffin, silicone oils and greases, water and aqueous solutions, refrigerants (ammonia, carbon dioxide, Freon), naphthenic mineral oils, low molecular aliphatic hydrocarbons (propane, butane, fuel), brake fluids based on glycol, better resistance to ozone, weathering and aging compared to NBR rubber.
Y	Epichloridrin	ECO	-30 ÷ +110	Mineral oils and greases, aliphatic hydrocarbons (propane, butane and gasoline), silicone oils and greases, water at room temperature, resistance to ozone, aging and weathering.
V	Fluorocarbon	FPM	-10 ÷ +150	Mineral oils and greases, non-flammable fluids of HFD group, silicone oils and greases, animal and vegetable oils and greases, aliphatic hydrocarbons (gasoline, butane, propane, natural gas), aromatics hydrocarbons (benzene, toluene), chlorinated hydrocarbons (Tetrachloroethylene, carbon tetrachloride), fuel (regular, super and containing methanol), excellent resistance to ozone, weathering and aging.

For other hydraulic fluid and/or temperatures, please consult us.

6.3c

6.3.6 ORDER CODE

1	2	3	4	5	6	7	8	9
ASSA	5	P	4000	C	H	8	VT	- 7

1 Series
Additional bottle with ASME U-Stamp = **ASSA**

2 Nominal capacity (gallons)

1/4 (0.95 l)	=	1/4
1 (3.78 l)	=	1
2.5 (9.46 l)	=	2.5
5 (18.93 l)	=	5
10 (37.85 l)	=	10
15 (56.78 l)	=	15

3 Seals material material

Nitrile rubber (NBR)	=	P
Nitrile for low temp.	=	F
Nitril for hydrocarbons	=	H
Hydrogenated nitrile (HNBR)	=	K
Butyl (IIR)	=	B
Ethylene-propylene (EPDM)	=	E
Chloroprene (Neoprene)	=	N
Epichlorohydrin (ECO)	=	Y
Fluorocarbon (FPM)	=	V

4 Max working pressure (PS)

4000 PSI (275 bar) = **4000**
(3000 only for the version with connection L)

5 Body material

Carbon steel	=	C
Nickel coated carbon steel 25 μ	=	N
Nickel coated carbon steel 40 μ	=	M
Rilsan coating	=	V

9 Test and certification

ASME U-stamp
(ASME VIII div.1 appendix 22) = **7**

8 Top connection

Thread hole M12x1.5 plugged	=	VT
1/4" BSP ISO 228	=	G2
1/2" BSP ISO 228	=	G4
3/4" BSP ISO 228	=	G5
1" BSP ISO 228	=	G6
1"1/4 BSP ISO 228	=	G7
1"1/2 BSP ISO 228	=	G8

7 Bottom connection dimension

For the type of connection:

G 3/4" BSP ISO 228	=	5
1" BSP ISO 228	=	6
1"1/4 BSP ISO 228	=	7
1"1/2 BSP ISO 228	=	8
L (3÷5 l) 1" 1/4 SAE3000	=	7
(10÷55 l) 1" 1/2 SAE 3000	=	8
2" SAE 3000	=	9
H (3÷5 l) 1" 1/4 SAE6000	=	7
(10÷55 l) 1" 1/2 SAE 6000	=	8
2" SAE 6000	=	9

Special variants upon request

6 Bottom connection

BSP ISO 228 (std)	=	G
adapter for flange SAE 3000 Psi	=	L
adapter for flange SAE 6000 Psi	=	H

6.3.7 DIMENSIONS

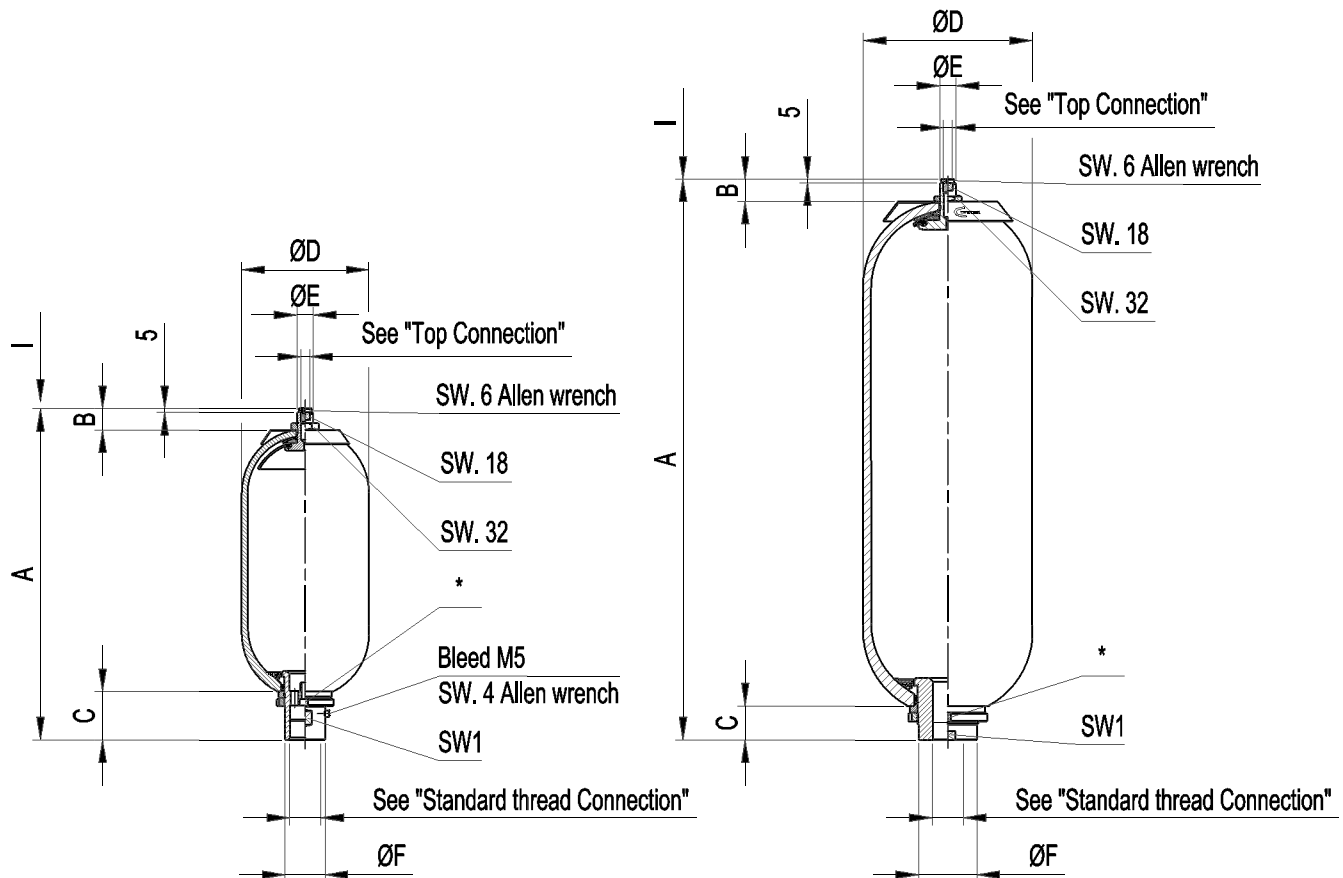


Fig. I

Fig. II

6.3da

Acc. type ASSA in carbon steel	Nominal gas volume gallons	Effective gas volume litres	Working pressure bar	Max. diff. pressure P2-P1 psi	Flow rate l/min	Max. comp. ratio P0/P2	Fig.	A mm	B mm	C mm	Ø D mm	Ø E mm	Ø F mm	I mm	SW 1 mm	Acc. dry weight kg
ASSA 1/4	1/4	1	4000	1450	300	1:4	I	261 ± 5	15	52	114	M22x1.5	36	140	32	11
ASSA 1	1	3,5	4000	1450	600	1:4	I	364 ± 10	20	65	168	M22x1.5	53	140	50	21
ASSA 2,5	2,5	9,1	4000	1450	1000	1:4	II	471 ± 10	30	45	223	M22x1.5	77	140	70	35
ASSA 5	5	18,2	4000	1450	1000	1:4	II	775 ± 10	30	45	223	M22x1.5	77	140	70	55
ASSA 10	10	33,5	4000	1450	1000	1:4	II	1309 ± 10	30	45	223	M22x1.5	77	140	70	91
ASSA 15	15	50	4000	1450	1000	1:4	II	1830 ± 10	30	45	223	M22x1.5	77	140	70	127

* see chapter 6.3.11 table 6.3dh

6.3db

- The maximum differential pressure is the maximum allowable difference between the maximum pressure and the minimum working pressure (P2-P1) to have an infinite life cycle of the accumulator (greater than 2,000,000 cycles).

- Flow rate measured using mineral oil with viscosity of 36 cSt at 50°C and ΔP = 5 bar

6.3.7.1 STANDARD THREAD CONNECTIONS

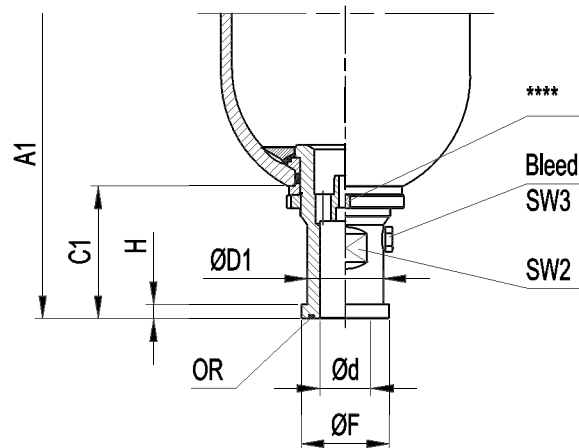
Dimensions	Connection Type	Accumulator type	Complete spare valve order code	Ød	ØD mm	ØF mm	H mm	
	G	ASSA 1/4"	V 2250-A5-***	1" 1/4 BSP	-	53	25	
		ASSA 1	V 2253-A7-***					
		BSP ISO 228	ASSA 2,5 + 15	V 2267-G5-***	3/4" BSP	-	77	20
				V 2267-G6-***	1" BSP	-	77	22
				V 2267-G7-***	1" 1/4 BSP	-	77	25
				V 2267-G8-***	1" 1/2 BSP	-	77	25

* Gasket material

** Components material

6.3dc

6.2.3.2 ADAPTER FOR FLANGE SAE 3000/6000 PSI (L/H)



6.3de

Acc. type ASSA in carbon steel	Dim.	A1 mm	C1 mm	SW2 mm	SW3 mm	Bleed	Ød mm	SAE 3000 (L)				SAE6000 (H)				OR	Acc. dry weight kg
								Spare valve order code	ØD1 mm	ØF mm	H mm	Spare valve order code	ØD1 mm	ØF mm	H mm		
ASSA 1/4"	-	-	-	-	-	-	-	-	-	-	-	-	-	-	-	-	
ASSA 1	-	-	-	-	-	-	-	-	-	-	-	-	-	-	-	-	
ASSA 2,5	1 1/2"	541 ± 10	115	42	19****	1/4" BSP	32	V 2064-L8-***	50	60,3	8	V 2064-H8-***	51	63,5	12,5	0010R4187-*	38
	2"			55	45	V 2064-L9-***	62	71,5	9,5	V 2064-H9-***	67	77,6	0010R4225-*				
ASSA 5	1 1/2"	845 ± 10	115	42	19****	1/4" BSP	32	V 2064-L8-***	50	60,3	8	V 2064-H8-***	51	63,5	12,5	0010R4187-*	58
	2"			55	45	V 2064-L9-***	62	71,5	9,5	V 2064-H9-***	67	77,6	0010R4225-*				
ASSA 10	1 1/2"	1379 ± 10	115	42	19****	1/4" BSP	32	V 2064-L8-***	50	60,3	8	V 2064-H8-***	51	63,5	12,5	0010R4187-*	94
	2"			55	45	V 2064-L9-***	62	71,5	9,5	V 2064-H9-***	67	77,6	0010R4225-*				
ASSA 15	1 1/2"	1900 ± 10	115	42	19****	1/4" BSP	32	V 2064-L8-***	50	60,3	8	V 2064-H8-***	51	63,5	12,5	0010R4187-*	130
	2"			55	45	V 2064-L9-***	62	71,5	9,5	V 2064-H9-***	67	77,6	0010R4225-*				

* Gasket material

** Components material

*** Allen wrench

**** Ex. Wrench

***** see chapter 6.3.11 table 6.3dh

6.3df

6.3df

6.3.8 SPARE PARTS CODE (STANDARD VERSION)

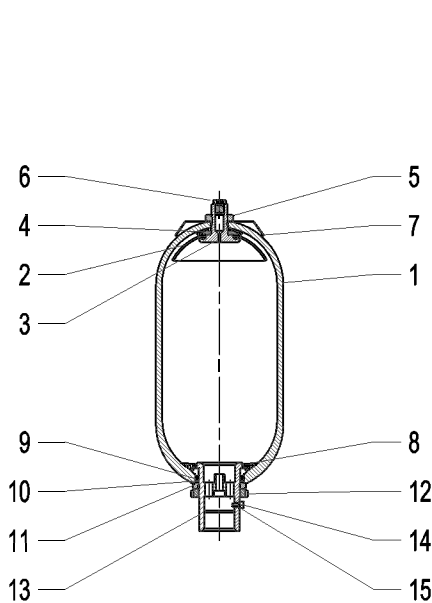


Fig. I

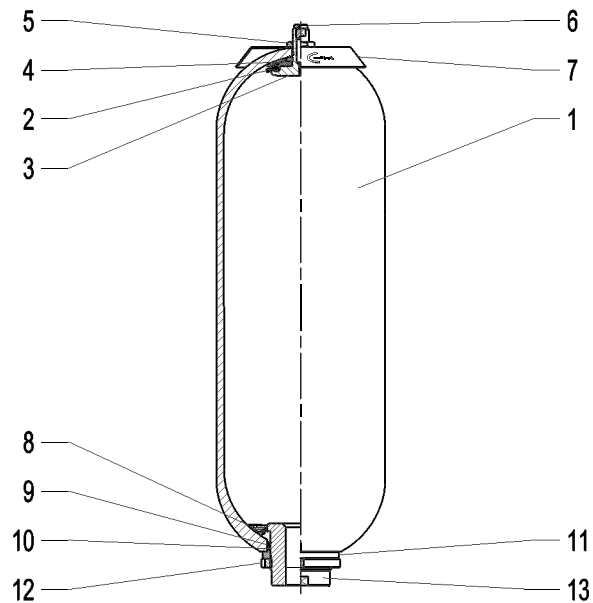


Fig. II

6.3dg

Item	Description	Q.ty	Type		
			ASSA 1/4 (Fig. I)	ASSA 1 (Fig. I)	ASSA 2,5+ 15 (Fig. II)
1	Accumulator shell	1	Not supplied as spare part		
2	Seal gas side	1	B11250 - *	B11252 - *	B10052 - *
3	Gas valve body	1	B10107 - **	B10202 - **	B10333 - **
4	Rubber-coated washer	1	B10106 - ** / *	B10205 - ** / *	B10334 - ** / *
5	Gas valve looknut	1	B10109 - **		B10302 - **
6	Plug	1	B10043 - **		
7	Name plate	1	D10300B-A	D10300C-A	D10300D-A
8	Retaining ring	1	B10146- ** / *	B10222 - ** / *	B10317 - ** / *
9	"O" ring	1	0010R0159 - *	0010R6212 - *	0010R0181 - *
10	Supporting ring	1	B10150-T	B10227-T	B10320-T
11	Space ring	1	B10223 - **		B10319 - **
12	Fluid port ring nut	1	B10217 - **		B10321 - **
13	Fluid port body	1	B10144 - *** - **		B10311 - *** - **
14	Bleed screw ****	1	B10128 - **		-
15	Seal ring ****	1	B10129-R		-
	Standard gas valve ass. (parts 2 + 6)	1	V 2033 - ** / *	V 2049 - ** / *	V 2270 - ** / *
	Standard fluid port ass. (parts 8 ÷ 15)	1	V 2250 - *** - ** / *	V 2253 - *** - ** / *	V 2267 - *** - ** / *
	Gasket sets	1	B2380-1- [*] { B11250- [*] 0010R0159- [*] B10150-T	B2381-1- [*] { B11525- [*] 0010R6212- [*] B10227-T	B2382-1- [*] { B10062- [*] 0010R0181- [*] B10320-T

* Gasket material

** Component material

*** See chapter 6.3.6 table 8 - 9

6.3dh

**** Only for Fig. I

6.3.9 EUROPE MARKET

All the additional bottles are pressure vessels and are subject to the national regulations and directives valid at the place of installation.

For additional bottles type ASSA, every shipping batch is complete of a conformity declaration and instructions of use and. All vessel categories (see Table 6.3d) must be protected by means of a pressure relief valve in accordance with Directive 97/23/EC.

6.3.10 ACCESSORIES

For support equipment, see section 7

For gas side's safety equipment, see section 8

For pre-loading and charging set, see section 11

For other components, see section 12

06.3.11 COMMISSIONING AND MAINTENANCE

Delivery condition.

Depending on the size and quantity ordered, the additional bottles are shipped in cartons or in cartons on pallets, or wooden boxes upon request. Unless otherwise required, certificates and documentation are provided together with the bottles.

Handling

The original packaging is suitable for handling and storage. Where necessary, you should use suitable lifting equipment to support the weight of the bottles. However protect from impact the packaging and handle it with care.

Storage

During storage in the warehouse, leave the product in its original packaging, keeping it away from heat sources and naked flames. The storage temperature should be between +10 and +40°C.

After six years of storage, it is essential to proceed with the replacement of all elastomeric parts before the commissioning.

Marking on the nameplate of the additional bottle:

The additional bottle will be supplied with the following data stamped on the nameplate:

- Logo, name and country of the manufacturer
- Month/year of production
- Product code
- Serial number
- Maximum PS pressure and PT test pressure in Psi
- Min. and max. TS working temperature in Fahrenheit
- Volume V in gallons
- ASME U-stamp
- Pre-charge pressure in Psi

It is strictly forbidden to:

- weld, rivet, bolt or screw any item of the cylinder shell
- engrave or permanently stamp the surfaces of the cylinder shell and / or carry out other operations that could affect or change the mechanical properties of the cylinder
- use the cylinder as a structural element: it should not be subjected to stresses or loads
- change the data of the nameplate and / or the cylinder without the permission of the manufacturer
- use a (dangerous) fluid of Group 1 with equipment designed and manufactured for fluids of Group 2.

Installation

Before installation, you must perform a visual check to verify that the bottles has not suffered any damage during shipping / handling.

Verify that the requested type matches with what stamped on the nameplate.

We recommend using the additional bottles connected to the accumulator with a suitable safety valve (see Chapter 8). This device provides user and equipment protection against possible damages due to pressure peaks.

The additional bottles type ASSA may be installed in any position from horizontal to vertical (preferably with the connections vertically) and the nameplate must be visible.

Proceed to the assembly so that no abnormal force affects the pipes connected directly or indirectly to the additional bottles, so we recommend the use of supporting components and also fastening (please see Chapter 7) to avoid the transmission of vibrations.

Make sure that the bottle is connected to the hydraulic circuit through suitable connection devices.

Make sure the gas is compatible with the elastomer of the seals.

Check that the max. allowed bottle pressure is equal to or greater than that of the hydraulic circuit and that the temperature during operation is maintained within the range expected.

Make sure the fluid does not contain contaminants.

Maintenance

- Periodically check the pre-charge pressure of the system: after the commissioning, check after 2-3 weeks of operation and if there were no leaks, repeat the operation after 3 months; if the pressure at the same temperature was stable, repeat the test yearly. For heavy-duty applications, check the pre-charge every 6 months.
- Periodically (yearly) carry out a visual inspection of the bottle in order to detect any early signs of deterioration such as corrosion, deformation, etc.
- Comply with the requirements of the regulations concerning the verification of the functionality of the equipment according to the country of installation of the bottle.

Disassembly

If for failure, scheduled check or retest it is necessary to remove the additional bottle from the system, prior to removal, completely discharge the pressure within the circuit.

All additional EPE cylinders of the ASSA series can be repaired.

Repair

It can consist in replacing the seals and/or parts of the valves.

For reasons of functionality and security, it is recommended to use only original spare parts.

Demolition and recycling of the additional cylinder

Before demolition or recycling of the additional cylinder, you should always discharge the internal pressure.

If you needed, proceed decontaminating in relation to the gas/fluid used prior to demolition.

6.3.12 SPANNER WRENCH

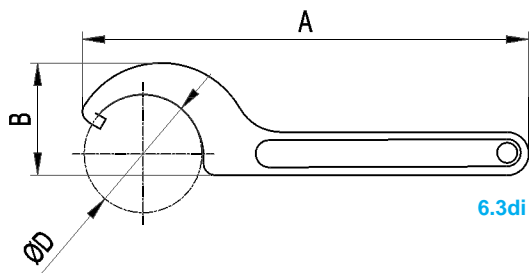
Fits all standard size bladder accumulator. It is used to remove or install lock nut on fluid port essembly.

0,7÷1,5 lt code 2506/58

3÷5 lt code 2506/68

10÷55 lt code 2506/105

Dimension



CODE	A	B	ØD
B2506/58	241	45	58
B2506/68	241	43	68
B2506/105	336	82	105

6.3dj

Reproduction Is Forbidden.

In The Spirit Of Continuous Improvement, Our Products May Be Changed.

6.4.1 TECHNICAL DATA

- MAX OPERATING PRESSURE (PS): 375 bar
- PRESSURE TEST (PT): 1.43 x PS
- NOMINAL CAPACITIES: 0.1 ÷ 1000 litres
- WORKING TEMPERATURE: -50 ÷ +150 °C
- BODY MATERIAL: - carbon steel shell painted with rust inhibitor RAL 8012
- nickel coating 25 - 40 μ
- FLUID PORT CONNECTION: upon request
- WEIGHT: see Table 6.4d

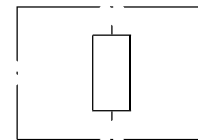
6.4.2 DESCRIPTION

Additional bottles type AB consist of a pipe of high-tensile steel. The same pipe of the piston accumulator type AP. The additional bottles are used to take in and store nitrogen to increase the gas volume in the accumulator station (with bladder or piston accumulator). This means that smaller accumulators can be used for the same gas volume and costs can be reduced. EPE offers a wide selection of bottles type, such as forged "B" version, shell of bladder accumulator "ASS" and "ASSA" version or body piston type "AB" version.

6.4.3 "AB" ADDITIONAL CYLINDERS ADVANTAGES

- compact
- simple construction
- quick, easy installation
- large volume

6.4.4 HYDRAULIC SYMBOL



6.4.5 SEALS-TEMPERATURE-LIQUID COMPATIBILITY

When selecting the additional cylinder variant, pay attention to the following non-binding notes with regard to hydraulic fluid, seals material and the permissive temperature range. (see Section)

Code letter	Polymer	ISO	Temperature range (°C)	Some of the liquids compatible with the polymer
P	Standard nitrile (Perburan)	NBR	-20 ÷ +80	Aliphatic hydrocarbons (propane, butane, gasoline, oils, mineral greases, diesel fuel, fuel oil, kerosene), mineral greases and oils, HFA - HFB - HFC fluids, many dilute acids, alkalis, saline solutions, water, water glycol.
F	Low temperature nitrile	NBR	-40 ÷ +70	The same as with standard nitrile + a number of different types of Freon. (This contains less acrylonitrile than the standard and is therefore more suitable for low temperatures, but its chemical resistance is slightly lower).
S	Silicon-fluorine	MVQ	-50 ÷ +150	Motor oils, animal and vegetable greases and oils, glycol-based brake fluids, flammable hydraulic fluids, HFD-R and HFD-S fluids, aromatic chlorinated hydrocarbons, water up to 100°C, dilute salt solutions, fuels, mineral aromatic oils and aromatic low molecular hydrocarbons.
V	Fluorocarbon	FPM	-10 ÷ +150	Mineral oils and greases, non-flammable fluids of HFD group, silicone oils and greases, animal and vegetable oils and greases, aliphatic hydrocarbons (gasoline, butane, propane, natural gas), aromatics hydrocarbons (benzene, toluene), chlorinated hydrocarbons (Tetrachloroethylene, carbon tetrachloride), fuel (regular, super and containing methanol), excellent resistance to ozone, weathering and aging.

For other hydraulic fluid and/or temperatures, please consult us.

6.4.6 ORDER CODE

1	2	3	4	5	6	7	8	9	10	11	
AB	200	P	220	C	350	G	6	G	5	-	8

<p>1 Series</p> <p>Additional bottle = AB</p>	<p>2 Nominal capacity (litres)</p> <p>Internal diameter</p> <p>∅ 60 mm = 0.1 ÷ 2.5</p> <p>∅ 100 mm = 1 ÷ 10</p> <p>∅ 180 mm = 6 ÷ 80</p> <p>∅ 250 mm = 30 ÷ 180</p> <p>∅ 350 mm = 80 ÷ 400</p> <p>∅ 520 mm = 180 ÷ 1000</p>	<p>3 Seals material material</p> <p>Nitrile rubber (NBR) = P</p> <p>Nitrile for low temp. = F</p> <p>Silicon-fluorine = S</p> <p>Fluorocarbon (FPM) = V</p>	<p>4 Max working pressure (bar)</p> <p>Internal diameter</p> <p>∅ 60 mm = 375</p> <p>∅ 100 mm = 375</p> <p>∅ 180 mm = 250 - 375</p> <p>∅ 250 mm = 250 - 350</p> <p>∅ 350 mm = 220 - 350</p> <p>∅ 520 mm = 220 - 350</p> <p>(210 only for the version with connection L or other pressure related to connections B or U)</p>	<p>5 Body material</p> <p>Carbon steel = C</p> <p>Nickel coated carbon steel 25 μ = N</p> <p>Nickel coated carbon steel 40 μ = M</p>	<p>6 Nominal internal diameter</p> <p>Internal diameter</p> <p>∅ 60mm = 60</p> <p>∅ 100mm = 100</p> <p>∅ 180mm = 180</p> <p>∅ 250mm = 250</p> <p>∅ 350mm = 350</p> <p>∅ 520mm = 520</p>	<p>7 Type of port connection A</p> <p>Without connection = 0</p> <p>Female thread:</p> <p>BSP ISO 228 = G</p> <p>BSP ISO 228 with chamfer for OR = A</p> <p>NPT-F = P</p> <p>SAE = S</p> <p>METRIC = M</p> <p>Holes for flange:</p> <p>SAE 3000 metric threads = L</p> <p>SAE 6000 metric threads = H</p> <p>ANSI metric threads = B</p> <p>UNI - DIN = U</p> <p>CETOP = C</p> <p>Special flange = F</p>	<p>8 Dimension of port connection A</p> <p>See the table on page 2</p>	<p>9 Type of port connection B</p> <p>Without connection = 0</p> <p>Female thread:</p> <p>BSP ISO 228 = G</p> <p>BSP ISO 228 with chamfer for OR = A</p> <p>NPT-F = P</p> <p>SAE = S</p> <p>METRIC = M</p> <p>Holes for flange:</p> <p>SAE 3000 metric threads = L</p> <p>SAE 6000 metric threads = H</p> <p>ANSI metric threads = B</p> <p>UNI - DIN = U</p> <p>CETOP = C</p> <p>Special flange = F</p>	<p>10 Dimension of port connection B</p> <p>See the table on page 2</p>	<p>11 Test and certification</p> <p>Factory testing = 0</p> <p>TR (Russia) = 1</p> <p>Australian Standard = 2</p> <p>ML (China) = 3</p> <p>RINA = 4</p> <p>PED97/23/EC (for capacity greater than 1 l) = 8</p> <p>ATEX 94/9EC = 9</p> <p>DNV = 10</p> <p>RTN Passport (Ukraine) = 11</p> <p>Algeria passport = 12</p> <p>Standard regulation (NR13) (Brazil) = 13</p> <p>Tunisia passport = 14</p>
---	--	--	--	--	--	---	---	---	--	---

8	Dimension of port connection A
Without connection = 0	
For the type of connection:	
G-A-P-L-H 1/8" = 1	
1/4" = 2	
3/8" = 3	
1/2" = 4 (std. DN 60)	
3/4" = 5	
1" = 6 (std. DN 100)	
1"1/4 = 7	
1"1/2 = 8 (std. DN 180-250-350)	
2" = 9 (std. DN 520)	
2"1/2 = 10	
3" = 11	
3"1/2 = 12	
4" = 13	
S = Diameter "inch"-Pitch "inch"	
Former. 9/16-18 = 9/16-18	
M = Diameter/pitch	
Former. M 22x1.5 = 22/1.5	
B = Dimension/Rating	
Former. 4" ANSI 300 = 4/300	
U = DN/PN	
Former. DN100 PN16 = 100/16	
C = Diameter "inch"/max Pressure "bar"	
Former. 3" Cetop 400 = 3/400	
F = to specify and EPE will assign a number	

9	Dimension of port connection B
Without connection = 0	
For the type of connection:	
G-A-P-L-H 1/8" = 1	
1/4" = 2	
3/8" = 3	
1/2" = 4 (std. DN 60)	
3/4" = 5	
1" = 6 (std. DN 100)	
1"1/4 = 7	
1"1/2 = 8 (std. DN 180-250-350)	
2" = 9 (std. DN 520)	
2"1/2 = 10	
3" = 11	
3"1/2 = 12	
4" = 13	
S = Diameter "inch" - Pitch "inch"	
Former. 9/16-18 = 9/16-18	
M = Diameter/pitch	
Former. M 22x1.5 = 22/1.5	
B = Dimension/Rating	
Former. 4" ANSI 300 = 4/300	
U = DN/PN	
Former. DN100 PN16 = 100/16	
C = Diameter "inch"/max Pressure "bar"	
Former. 3" Cetop 400 = 3/400	
F = to specify and EPE will assign a number	

6.4.7 EUROPE MARKET

All hydraulic bottles are pressure vessels and are subject to the national regulations and directives valid at the place of installation.

For additional cylinders type AB, every shipping batch is complete of a conformity declaration and instructions of use and maintenance and/or all documents requested. All vessel categories (see Table 6.4d) must be protected by means of a pressure relief valve in accordance with Directive 97/23/EC.

6.4.8 ACCESSORIES

For support equipment, see Cap. 7

For gas side's safety equipment, see Cap. 8

For pre-loading and charging set, see Cap. 11

For other components, see Cap. 12

6.4.9 DIMENSIONS

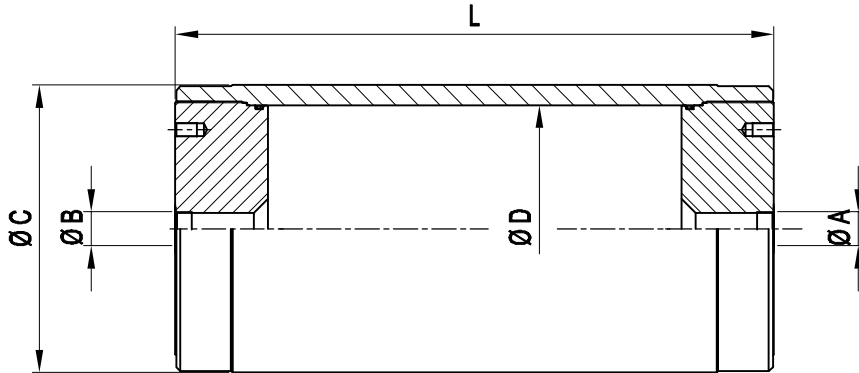


Fig. I

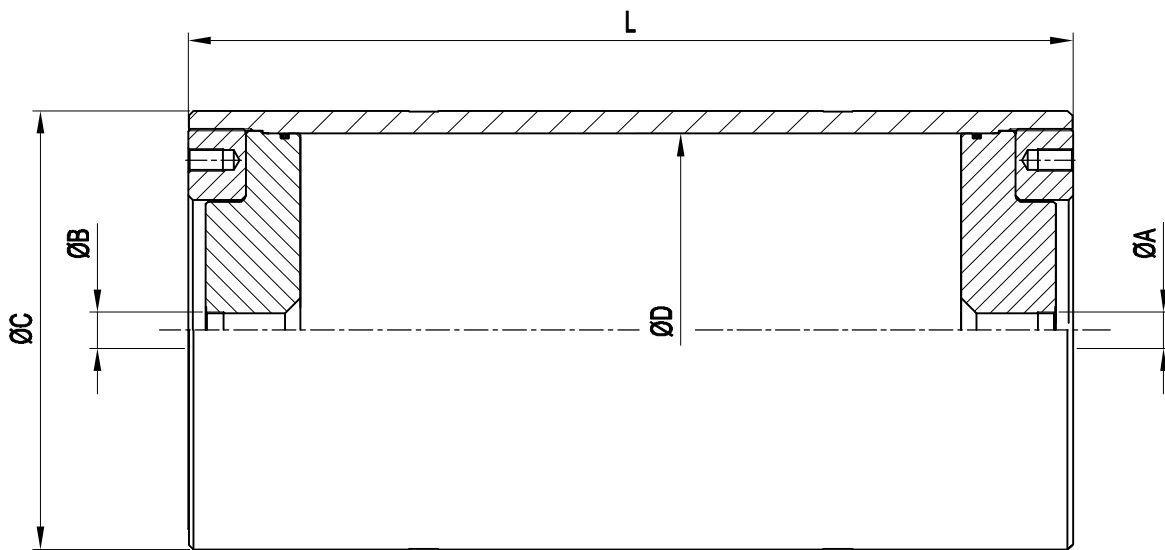


Fig. II

6.4d

Accumulator type APXXX Ø bore (ØD)	Fig	Gas capacity liters	Working pressure bar	Ped category for the liquids of group 2	Maximum differential pressure bar	ØA	ØB	ØC mm	ØD mm	L mm	Dry Weigh Kg			
											220 bar	250 bar	350 bar	375 bar
60	I	0,25	375	Art III (III)	300	Pre-charge valve 5/8" UNF	1/2" BSP	80	60	169			4,9	
		0,5								258			6,4	
		1		436								9,5		
		1,5		614								12,5		
		2		790								15,5		
100	I	1	375	II	300	Pre-charge valve 5/8" UNF	1" BSP	130	100	240			17,1	
		1,5								304			19,8	
		2								368			22,6	
		2,5								430			25,2	
		3								494			27,9	
		4		622								33,3		
		5		750								38,7		
		6		878								44,1		
		8		1134								54,9		
		10		1390								65,8		
180	I	6	250	IV	180,5	Pre-charge valve 5/8" UNF	1 1/2" BSP	220	180	418			74,0	
		8								495			81,5	
		10								573			89,2	
		15								652			96,9	
		20								771			108,6	
		25	968							127,9				
		30	1163							147,0				
		40	1360							166,6				
		50	1754							204,9				
		60	2145							243,2				
80	2538			281,8										
250	I	30	250	IV	180	Pre-charge valve 5/8" UNF	1 1/2" BSP	292	250	983	229,6	302,3		
		40								1188	258,3	346,2		
		50								1388	283,3	389,0		
		60								1593	315,0	432,9		
		80								1998	317,7	519,5		
		100	2408		429,1			607,3						
		120	2818		486,5			695,5						
		150	3428		571,9			825,5						
		180	4038		657,3			966,1						
350	I	100	220	IV	165	Pre-charge valve 5/8" UNF	1 1/2" BSP	406	350	1552	643,1		772,5	
		120								1762	698,4		841,5	
		150								2072	780,0		942,6	
		180								2382	861,4		1036	
		200	2595		916,6					1212,6				
		250	3112		1053,4					1282,7				
		300	3632		1190,2					1452,7				
		400	4722							1806,7				
520	II	200	220	IV	120	Pre-charge valve 5/8" UNF	2" BSP	580	520	1570	1141,3			
		250								1806	1230,1			
		300								2041	1318,2			
		350								2276	1407,7			
		400								2511	1495,4			
		500			2982					1672,1				
		600			3453					1849,1				
		800			4395					2204,2				
		1000			5337					2558,0				

6.4e

* The maximum differential pressure is the maximum allowable difference between the maximum pressure and the minimum working pressure (P2-P1) to have an infinite life cycle of the accumulator (greater than 2,000,000 cycles).

6.4.10 SPARE PARTS CODES

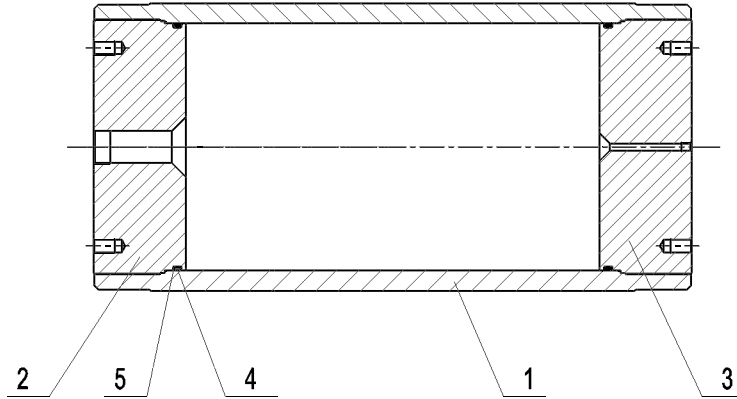


fig. I

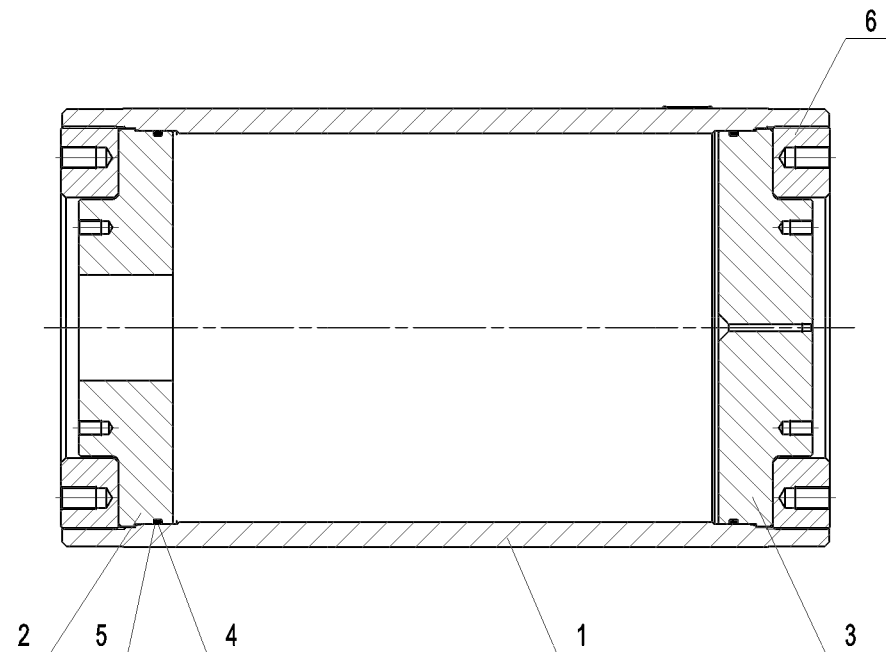


fig. II

6.4f

Pos.	Spare parts	Cylinder diameter	Fig.	Group code	Q.ty	Part description	Type / Code
1	Not supplied as spare parts					Accumulator cylinder	-
2						Oil side cap	
3						Gas side cap	
4	Accumulator gasket set	60	I	B2471-1 *	2	O - ring	0010R6200 - *
5					2	Anti-extrusion ring	0011P8329 - *
4	Accumulator gasket set	100	I	B2472-1 *	2	O - ring	0010R0185 - *
5					2	Anti-extrusion ring	0011P8341 - *
4	Accumulator gasket set	180	I	B2473-1 *	2	O - ring	0010R0228 - *
5					2	Anti-extrusion ring	0011P8439 - *
4	Accumulator gasket set	250	I	B2474-1 *	2	O - ring	0010R8925 - *
5					2	Anti-extrusion ring	0011P8447 - *
4	Accumulator gasket set	350	I	B2475-1 *	2	O - ring	0010R81300 - *
5					2	Anti-extrusion ring	0011P8455 - *
4	Accumulator gasket set	520	II	B2476-1 *	2	O - ring	0010R82000 - *
5					2	Anti-extrusion ring	0011P8469 - *
6	Not supplied as spare parts					Thread ring	-

* Gasket material

6.4g

6.4.11 COMMISSIONING AND MAINTENANCE

Delivery condition

The additional bottles type AB are shipped on pallets or wooden boxes upon request. Unless otherwise required, certificates and documentation are provided together with the bottles.

Handling

The original packaging is suitable for handling and storage. Where necessary, you should use suitable lifting equipment to support the weight of the bottles. However protect from impact the packaging and handle it with care.

Storage

During storage in the warehouse, leave the product in its original packaging, keeping it away from heat sources and naked flames. The storage temperature should be between +10 and +40°C. After six years of storage, it is essential to proceed with the replacement of all elastomeric parts before the commissioning.

Marking on the nameplate of the additional cylinder

With reference to the PED 97/23/EC classification, Article 3, Paragraph 3 and / or risk categories I or IV depending on the volume and maximum working pressure, the cylinder indicates the following data:

- logo, name and country of the manufacturer
- month / year of production
- product code
- serial number
- maximum PS pressure and PT test pressure in bar
- min. and max. TS working temperature in Celsius
- volume V in litres
- group of fluids allowed
- CE marking (by category I ÷ IV) with the identification number of the notified body

It is strictly forbidden to:

- weld, rivet, bolt or screw any item of the cylinder shell
- engrave or permanently stamp the surfaces of the cylinder shell and / or carry out other operations that could affect or change the mechanical properties of the cylinder
- use the cylinder as a structural element: it should not be subjected to stresses or loads
- change the data of the nameplate and / or the cylinder without the permission of the manufacturer
- use a (dangerous) fluid of Group 1 with equipment designed and manufactured for fluids of Group 2.

Installation

Before installation, you must perform a visual check to verify that the bottles has not suffered any damage during shipping / handling.

Verify that the requested type matches with what stamped on the nameplate. We recommend using the additional bottles connected to the accumulator with a suitable safety valve (see Chapter 8). This device provides user and equipment protection against possible damages due to pressure peaks.

The additional bottles type AB may be installed in any position from horizontal to vertical (preferably with the connections vertically) and the nameplate must be visible.

Proceed to the assembly so that no abnormal force affects the pipes connected directly or indirectly to the additional bottles, so we recommend the use of supporting components and also fastening (please see Chapter 7) to avoid the transmission of vibrations.

Make sure that the bottle is connected to the hydraulic circuit through suitable connection devices.

Make sure the gas is compatible with the elastomer of the seals.

Check that the max. allowed bottle pressure is equal to or greater than that of the hydraulic circuit and that the temperature during operation is maintained within the range expected.

Make sure the fluid does not contain contaminants.

Maintenance

- Periodically check the pre-charge pressure of the system: after the commissioning, check after 2-3 weeks of operation and if there were no leaks, repeat the operation after 3 months; if the pressure at the same temperature was stable, repeat the test yearly. For heavy-duty applications, check the pre-charge every 6 months.
- Periodically (yearly) carry out a visual inspection of the bottle in order to detect any early signs of deterioration such as corrosion, deformation, etc.
- Comply with the requirements of the regulations concerning the verification of the functionality of the equipment according to the country of installation of the bottle.

Disassembly

If for failure, scheduled check or retest it is necessary to remove the additional bottle from the system, prior to removal, completely discharge the pressure within the circuit.

All additional EPE cylinders of the AB series can be repaired.

Repair

It may consist in replacing the seals.

For reasons of functionality and security, it is recommended to use only original spare parts.

Demolition and recycling of the additional cylinder

Before demolition or recycling of the additional cylinder, you should always discharge the internal pressure.

If needed, proceed decontaminating in relation to the gas/fluid used prior to demolition.

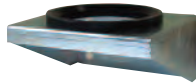
Reproduction is forbidden.

In the spirit of continuous improvement, our products may be changed.



CLAMPS type C

7.1



BRACKETS type MA and SUPPORT RING type AG

7.2



U-BOLTS type U and PLASTIC SADDLES type P

7.3



SINGLE ACCUMULATOR UNIT type BA1S

7.4

7.1.1 DESCRIPTION

The mounting clamps can be used with all type of accumulators. Secure design provides independent mounting on installations.

Rubber insert provided to reduce mechanical vibration, to compensate for shell manufacturing tolerances and to not lie with outward stresses on the connection.

The clamp type C90 has one piece construction with one central screw. All other types have a two pieces construction for easy installation and removal while improving the strength to weight ratio.

We recommend using a single clamp when the length of the accumulator is less than twice the diameter.

For greater lengths, we recommend using two clamps or one clamp and one bracket with support ring.

7.1.2 CONSTRUCTION

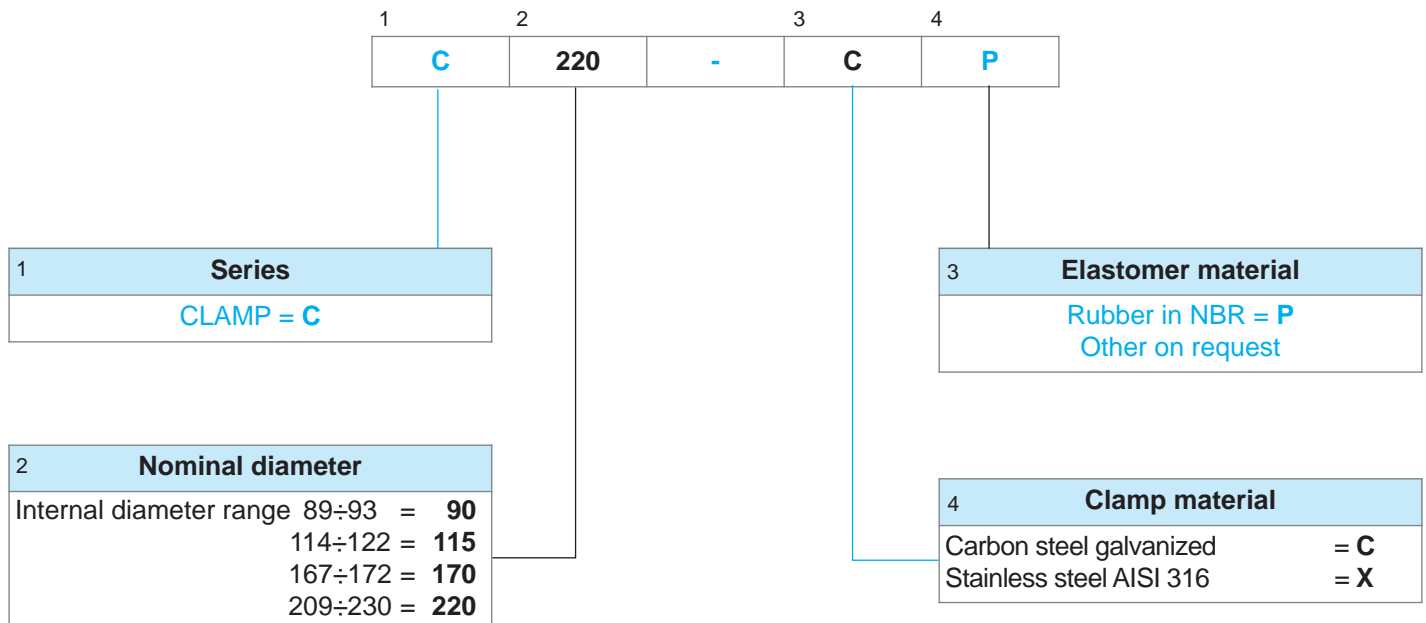
The clamps are manufactured of galvanized carbon steel in compliance to directive 2002/95/CE (RoHS) for resist to the corrosion, on request they can be supplied in stainless steel version.

The rubber insert is black NBR rubber nitrile at 80 Shore A.



7.1a

7.1.3 ORDER CODE



7.1.4 DIMENSIONS

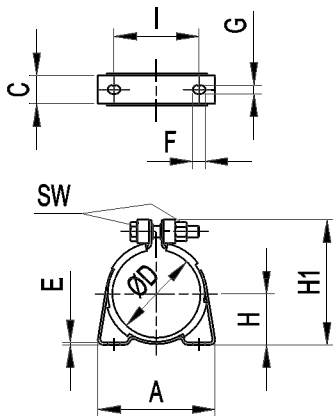


fig. I

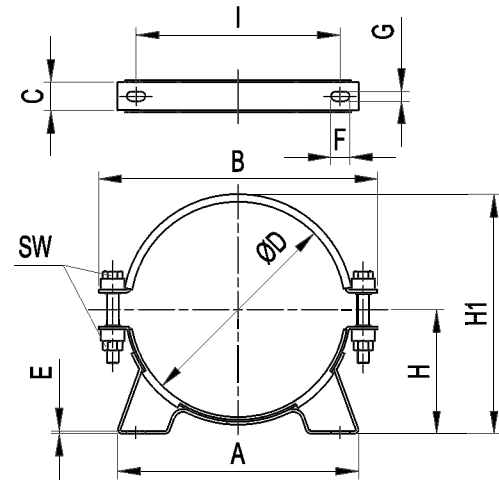


fig. II

7.1b

Clamp nominal size	Clamp order code	Fig.	A mm	B mm	C mm	Ø D mm	E mm	F mm	G mm	H mm	H 1 mm	I mm	SW mm	Acc. dry weight kg
90	C90-**/*	II	125	-	30	89+93	2.5	13	9	53 + 55 (9 + 1/2 ØD)	132.5	90	18	0,65
115	C115-**/*	II	135	195	30	114+122	3	13	9	66 + 70 (9 + 1/2 ØD)	131+139 (17+ØD)	100	18	0,85
170	C170-**/*	II	185	250	30	167+172	3	13	9	95.5 + 98 (12 + 1/2 ØD)	187 + 192 (20+ØD)	146	18	1,1
220	C220-**/*	II	255	295	30	209+230	3	20	10	117 + 127.5 (12.5 + 1/2 ØD)	230 + 251 (21+ØD)	216	18	1,35

7.1c

7.1.5 USAGE TABLE

Clamp nominal size	Int. Ø dimension	Bladder accumulator type	Piston accumulator type	Diaphragm accumulator type	Additional bottle type
90	89 + 93	AS / ASP 0.7 ASL 0.7	-	AMS 0.32 - 0.75	
115	114+122	AS / ASP 1 - 1.5 - 3 ASL / AST 1 - 1.5 - 3 ASB 1.5 - 3 ASBL / ASBT 1.5 - 3 ASA 1/4	-	AM 0.5 - 0.75 - 1.5 - 2.5 AML 0.8 - 1.5	ASS 3 ASSA 1/4
170	167+172	AS / ASP 5 ASL / AST 5 ASB 1.5 - 3 ASBL / ASBT 1.5 - 3 ASA 1	-	-	ASS 5 ASSA 1
220	209+230	AS / ASP 10 + 55 ASL / AST 10 + 55 ASB 10 + 55 ASBL / ASBT 10 + 55 ASA 2.5 + 15	AP *****/** 180	-	B 52-75 ASS 10 + 55 ASSA 2.5 + 15 AB *****/** 180

7.1d

Reproduction Is Forbidden.

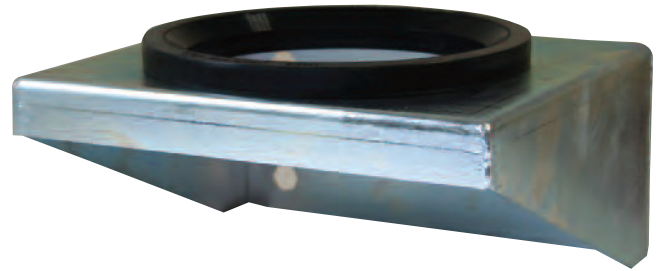
In The Spirit Of Continuous Improvement, Our Products May Be Changed.

7.2.1 DESCRIPTION

Brackets can be used with all type of accumulators. Secure design provides independent mounting on installations.

Rubber insert provided to reduce mechanical vibration, to compensate for shell manufacturing tolerances and to not lie with outward stresses on the connection.

The brackets can be easily bolted to the system. We recommend using a bracket and support ring with one or two clamps or U-bolts.



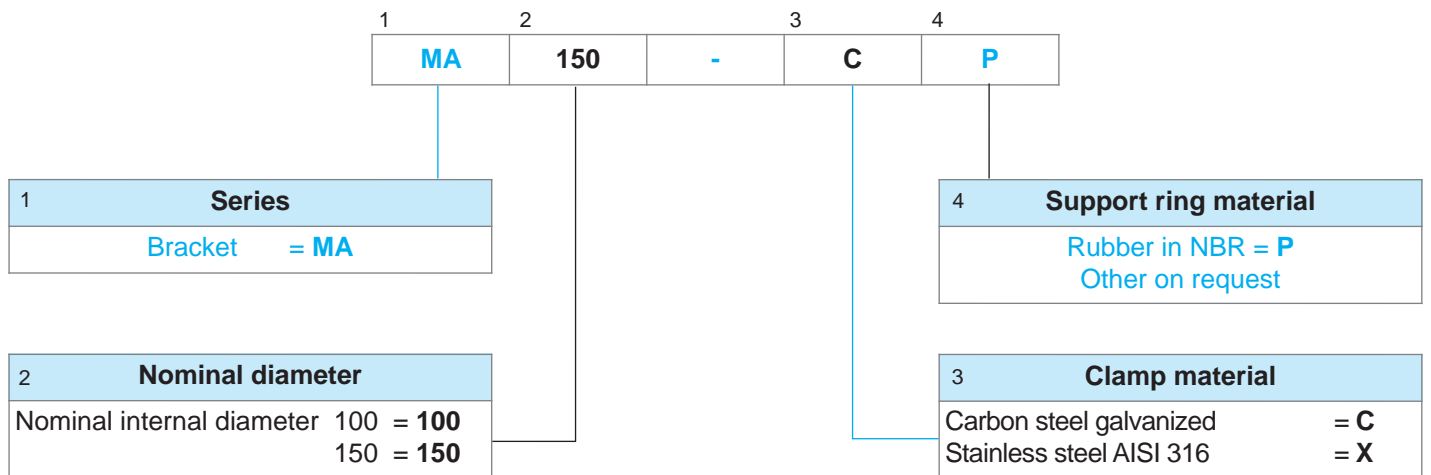
7.2a

7.2.2 CONSTRUCTION

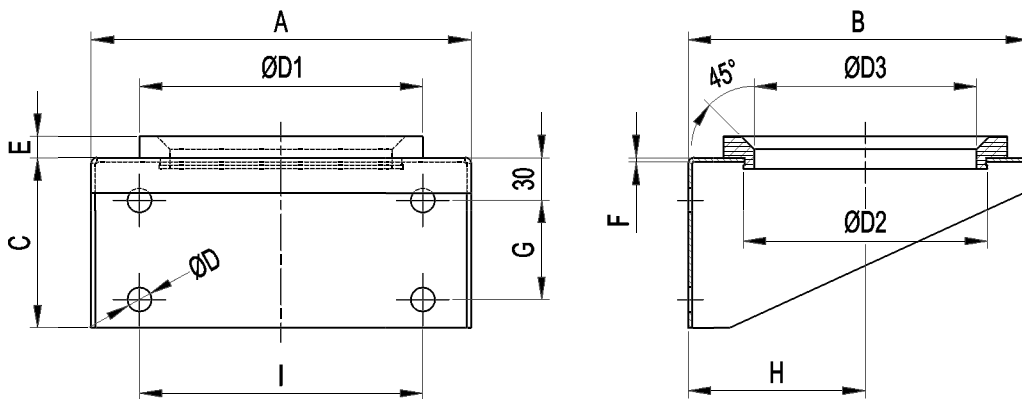
All the brackets are manufactured of galvanized carbon steel in compliance to directive 2002/95/CE (RoHS) for resist to the corrosion, on request they can be supplied in stainless steel version.

The support ring is manufactured of black NBR rubber nitrile at 85 Shore A.

7.2.3 BRACKET ORDER CODE



7.2.4 BRACKET DIMENSIONS



7.2b

Bracket nominal size	A	B	C	øD	øD1	øD2	øD3	E	F	G	H	I	Weight (Kg)
100	200	175	90	11	140	120	90	10	3	40	96	140	1,5
150	260	232	120	17	200	170	150	15	3	70	125	200	3,6

7.2c

7.2.5 SUPPORT RING ORDER CODE

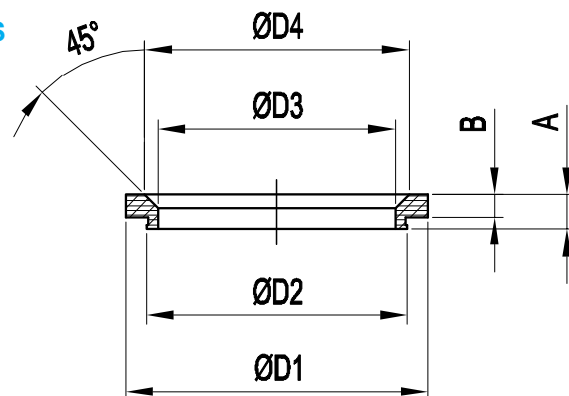


1	Series
	Support ring = AG

2	Nominal diameter
	Nominal internal diameter 100 = 100 150 = 150

3	Support ring material
	Rubber in NBR = P Other on request

7.2.6 SUPPORT RING DIMENSIONS



7.2e

Support Ring nominal size	A	B	øD1	øD2	øD3	øD4	Weight (Kg)
100	18	10	140	120	90	112	0,13
150	23	15	200	170	150	175	0,22

7.2f

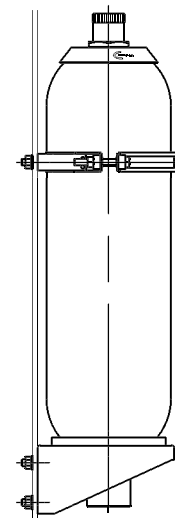
7.2.7 USAGE TABLE

Bracket nominal size	Supporting ring nominal size	Bladder accumulator type	Additional bottle type
100	100	AS / ASP 5 ASL / AST 5 ASB 1.5 - 3 ASBL / ASBT 1.5 - 3 ASA 1	ASS 5 ASSA 1
150	150	AS / ASP 10 + 55 ASL / AST 10 + 55 ASB 10 + 55 ASBL / ASBT 10 + 55 ASA 2.5 + 15	B 52-75 ASS 10 + 55 ASSA 2.5 + 15 AB */**/* 180

7.2g

7.2.8 MOUNTING

Example for mounting.



7.2h

Reproduction Is Forbidden.

In The Spirit Of Continuous Improvement, Our Products May Be Changed.

7.3.1 DESCRIPTION

Round U-bolts clamp with plastic saddles can be used with all type of accumulators.

Secure design provides independent mounting on installations. The plastic saddle provided to reduce mechanical vibration, to compensate for shell manufacturing tolerances and to not lie with outward stresses on the connection.

We recommend using a single U-bolt when the length of the accumulator is less than twice the diameter. For greater lengths, we recommend using two or three U-bolts with saddles.

7.3.2 CONSTRUCTION

The all U-bolts are manufactured of galvanized carbon steel in compliance to directive 2002/95/CE (RoHS) for resist to the corrosion, on request they can be supplied in stainless steel version.

The U-bolts are supplied with two hex nuts UNI 5588 CLASS 8 A 2-70 and two washer UNI6592 class 100 HV.

The plastic saddles are manufactured of green polypropylene.



7.3.3 U-BOLT ORDER CODE



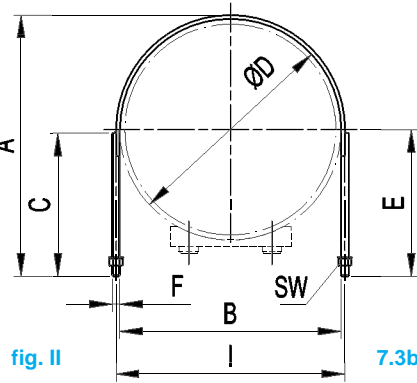
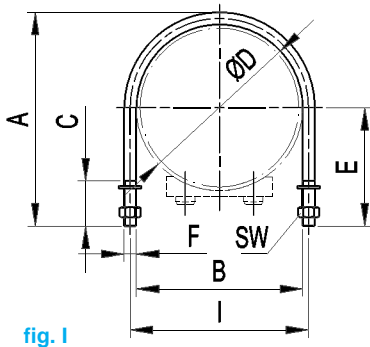
7.3a

1	Series
	U - bolt = U

3	Material
	Carbon steel galvanized = C
	Stainless steel AISI 316 = X

7.3.4 U-BOLT DIMENSIONS

2	Nominal diameter
	Nominal internal diameter 115 = 115
	130 = 130
	168 = 168
	220 = 220
	312 = 312
	420 = 420
	585 = 585



U-Bolt nominal size	fig.	A	B	C	øD	E	F	I	SW	Weight (Kg)
115	I	149	115	35	115	84	M8	123	13	0,12
130	I	177	140	35	140	99	M8	148	13	0,15
168	I	211	168	45	168	118	M10	178	17	1,74
220	I	282	220	60	220	157	M16	236	24	2,75
312	I	399	324	70	324	217	M20	344	30	2,16
420	I	475	425	75	425	298	M20	445	30	3
585	II	611	585	75	585	308	M20	605	30	3,78

7.3.5 PLASTIC SADDLE ORDER CODE

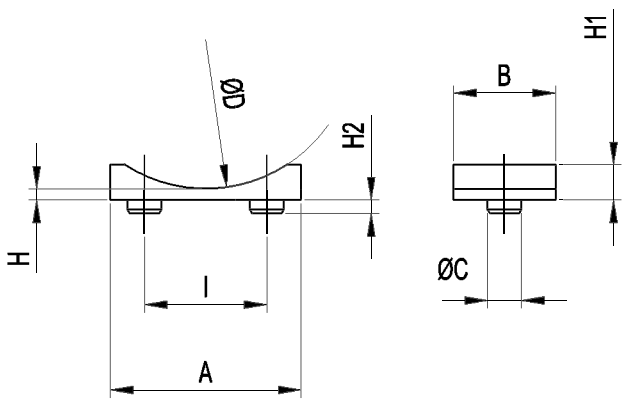


1	Series
	Plastic saddle = P

3	Material
	Green polypropylene = PP Other on request

7.3.6 PLASTIC SADDLE DIMENSIONS

2	Nominal diameter
	Nominal diameter of the tube 114 = 115 133 = 130 168 = 168 219 = 220 316 = 312 419 = 420

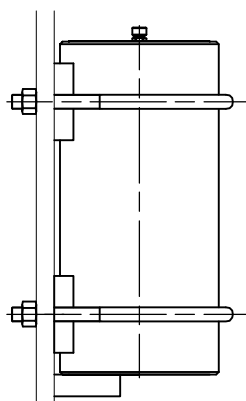


7.3c

Saddles nominal size	A	B	ØC	øD	H	H1	H2	I
115	75	70	15	113	8	17	10	40
130	75	70	15	133	8	17	10	40
168	140	75	25	168	8	26	10	90
220	140	75	25	219	8	26	10	90
312	220	75	30	318	8	32	10	150
420	220	75	30	419	8	32	10	150

7.3.7 MOUNTING

Example for mounting.



7.3c

Reproduction Is Forbidden.
In The Spirit Of Continuous Improvement, Our Products May Be Changed.

7.4.1 DESCRIPTION

The single accumulator unit consist of a bladder accumulator (1 ÷ 50 liters or 1/4 ÷ 15 gallons), a safety and shut-off block and the appropriate steel support.

This solution is designed in order to simplify the mounting at the installation site, the connection of the accumulator to the hydraulic system, and in order to reduce the assembling costs.

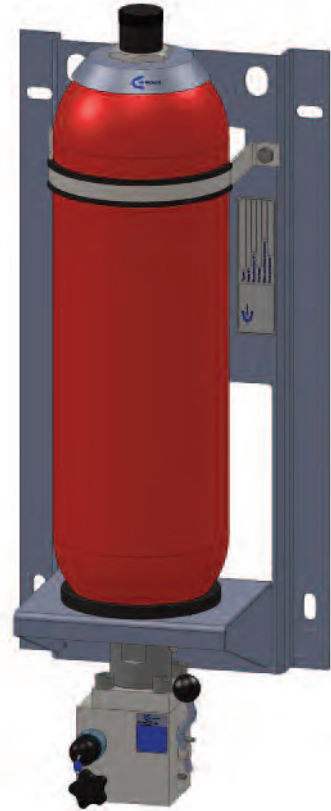
7.4.2 CONSTRUCTION

All the single accumulator units are manufactured of galvanized carbon steel in compliance to directive 2002/95/CE (RoHS) for resist to the corrosion, on request they can be supplied in stainless steel version.

DESIGN: Pressure Equipment Directive PED 97/23/EC (others on request)

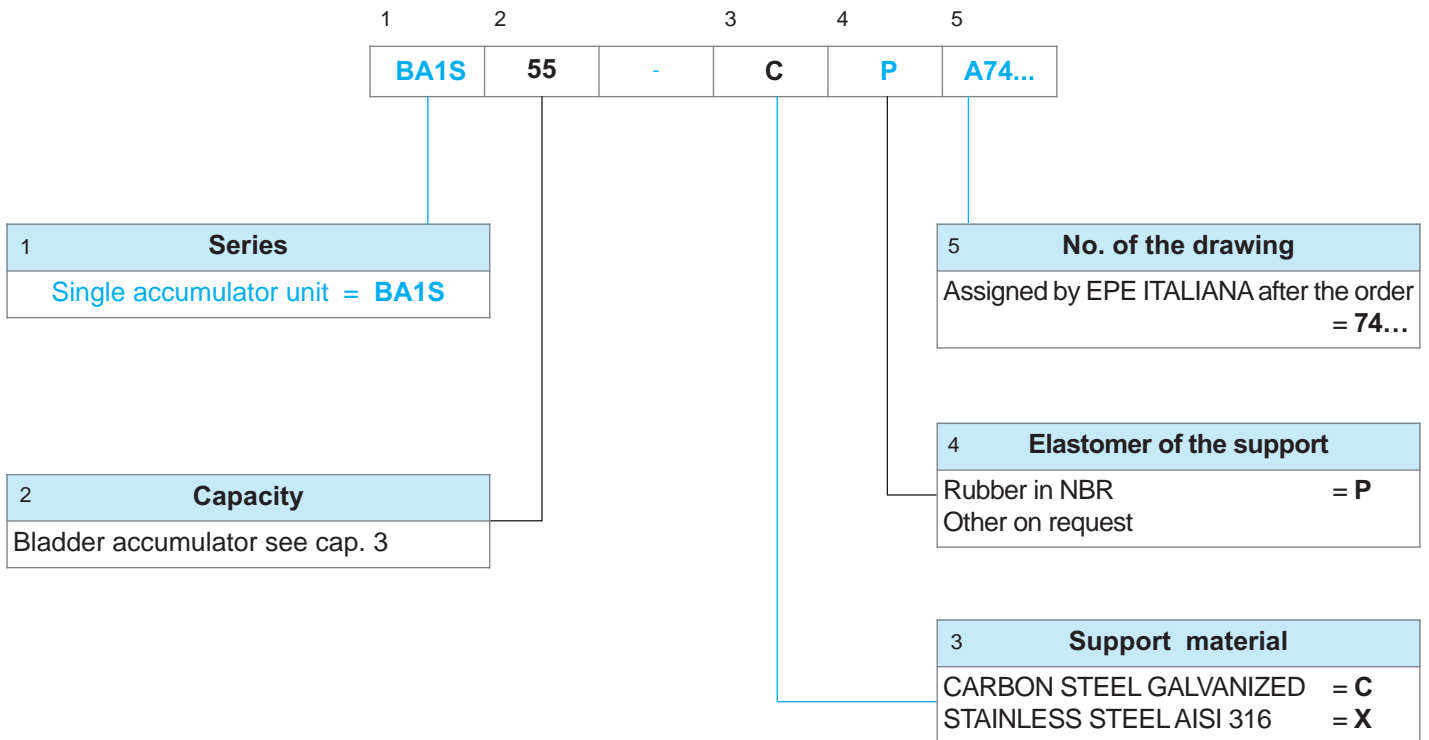
CONSTRUCTION:

- accumulator AS: see section 3.1
- accumulator low pressure type ASB: see section 3.3
- accumulator ASA: see section 3.5
- safety and shut-off block: see section 8 and 9

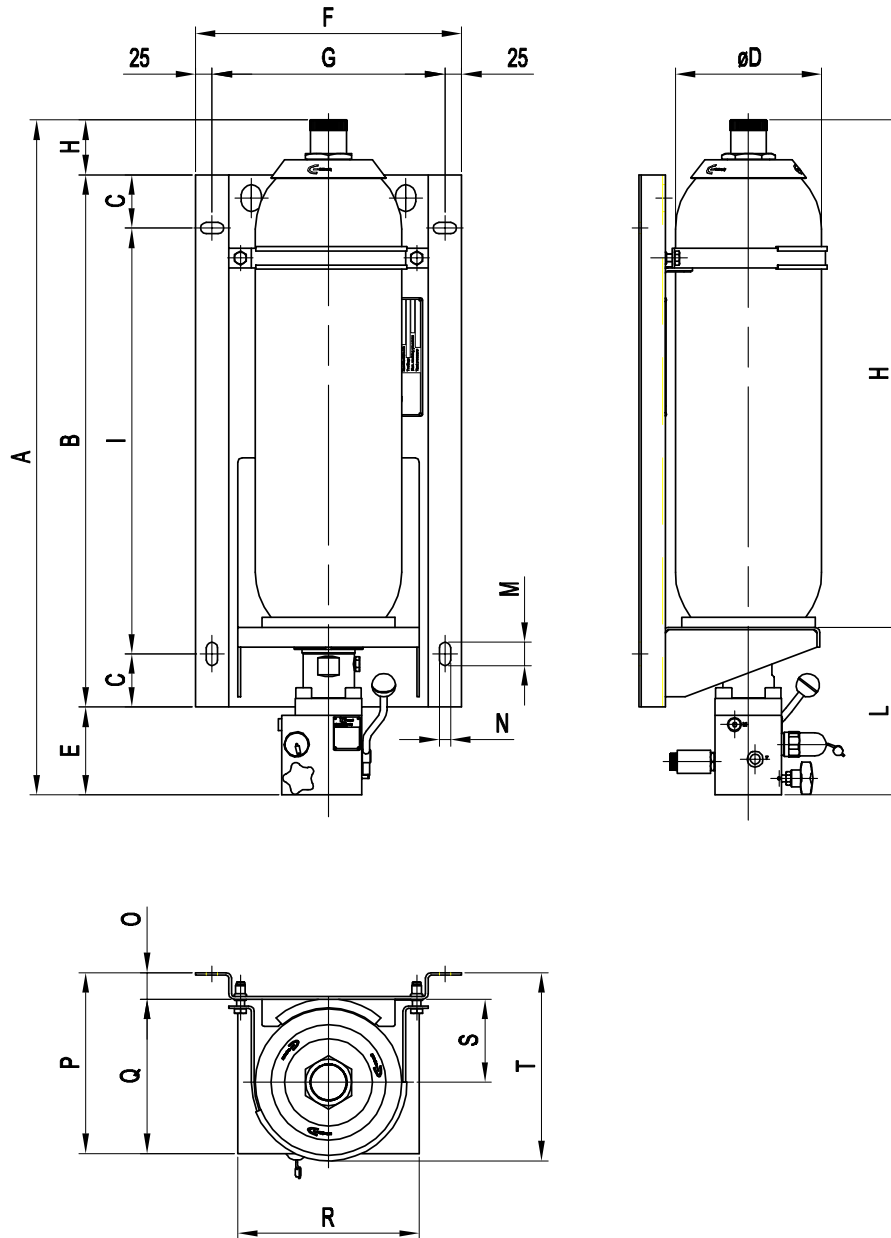


7.4a

7.4.3 ORDER CODE



7.4.5 DIMENSIONS



7.4b

Accumulator type	A	B	C	ϕD	E	F	G	H	H1	H2	I	L	M	N	O	P	Q	R	S	T	U	V	Z
AS10	707	540	40	220	142	25	350	445	635	120	460	400	25	17	35	262	232	270	125	283	40	4	272
AS15	857	540	40	220	142	175	350	595	785	120	460	400	25	17	35	262	232	270	125	283	40	4	272
AS20	1017	790	60	220	142	85	350	755	945	120	670	400	25	17	35	262	232	270	125	283	40	4	272
AS25	1182	790	60	220	142	250	350	920	1110	120	670	400	25	17	35	262	232	270	125	283	40	4	272
AS35	1532	1360	80	220	142	30	350	1270	1460	120	1200	400	25	17	35	262	232	270	125	283	40	4	272
AS55	2042	1360	80	220	142	540	350	1780	1970	120	1200	400	25	17	35	262	232	270	125	283	40	4	272

Reproduction Is Forbidden.

In The Spirit Of Continuous Improvement, Our Products May Be Changed.



SAFETY VALVES type VS

8.1



BURST AND FUSE DISK type DR and DF

8.2



GAS SIDE ADAPTERS type TG

8.3



SHUT OFF 2-WAY VALVES GAS SIDE

8.4



SHUT OFF 3-WAY VALVES GAS SIDE

8.5



CHARGING AND SHUT-OFF SAFETY BLOCK type BC

8.6

8.1.1 TECHNICAL DATA

MAX OPERATING PRESSURE (PS): 360 bar

PRESSURE SETTING (P): 10 ÷ 360 (upon request)

ORIFICE: 9.5 mm

LIFT: 2 mm

WORKING TEMPERATURE: -40 ÷ +150 °C

REPETIBILITY: ± 3% of P

CALIBRATION ERROR: < 3%

OVERPRESSURE BY FULL FLOW: 10% of P

BLOW DOWN: 10% of P

GAS DISCHARGE COEFFICIENT (K): 0.95

LIQUID DISCHARGE COEFFICIENT (K): 0.6

BODY MATERIAL: stainless steel AISI 316L

SEALING MATERIAL: Delrin (POM)

CONNECTIONS: 3/4" BSP ISO228

FLOW RATE: see Table 5.1d

WEIGHT: see Table 5.1d

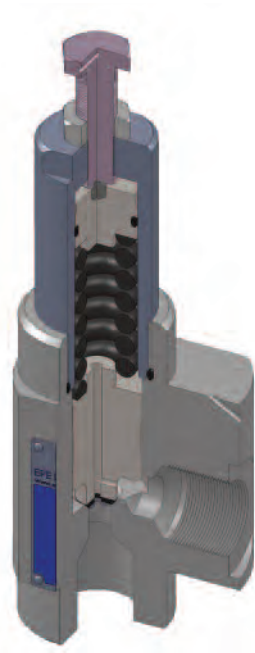
8.1.2 DESCRIPTION

The safety valves VS224 are designed and manufactured by Epe Italiana. They have soft seal and total lift. They have a high flow coefficient (K = 0.95) and are suitable for gas and liquids.

VS224 valves are safety devices as specified in Article 1, Section 2.1.3 of Directive 97/23/EC and are subject to Article 3, Section 1.4 of the same Directive.

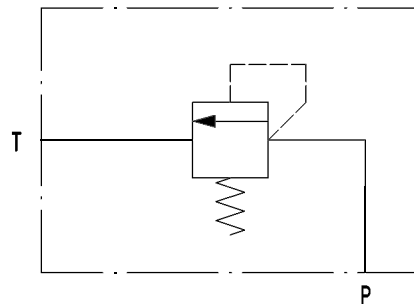
These valves are direct acting safety valves, used for protection against overpressure with respect to the operating conditions of the accumulators. They can be installed directly on the accumulator, through the appropriate use of adapters (see Cap.8.3) or on the safety block on the gas side (BC32G) or on joint on the gas side connection of the accumulator stations.

The valve opening is determined by the force exerted by the fluid under pressure on the poppet in contrast with the spring acting on the cut-off itself.



8.1a

8.1.3 HYDRAULIC SYMBOL



8.1b

8.1.4 CONSTRUCTION

Body: of stainless steel AISI316L, obtained by mechanical processing, in which are obtained the connections and the seal seat.

Poppet: obtained by mechanical processing from bar and provided with a seal, it ensures the necessary seal degree on the valve seat. The seal is made of DELRIN (POM), a material that, over the estimated useful life for the valve, maintains good strength and does not cause phenomena of poppet sticking on the seat. The poppet is well led and pushed by the spring.

Spring: it counteracts the pressure and the dynamic actions of the fluid and always ensures the closing of the valve after the discharge.

The coils of the spring, even when the poppet has reached its maximum lift, are never at pack.

The poppet has a mechanical lock and when it has reached it, the arrow of the spring does not exceed 85% of the maximum deviation.

Calibration system: threaded hexagon head screw which screws into the top of the valve by compressing the spring below. After the calibration, the position of the adjusting screw is kept unaltered by locking the counter nut and sealing the adjusting screw to the body.

8.1.5 CALIBRATION

All valves are calibrated on the working bench with atmospheric counter pressure. The repeatability error of calibration is less than 3% of P.

The leak test is performed according to API Standard 527: with air under water and up to a pressure equal to 97% of the calibration pressure verifying that, there's no beackages.

8.1.6 ORDER CODE

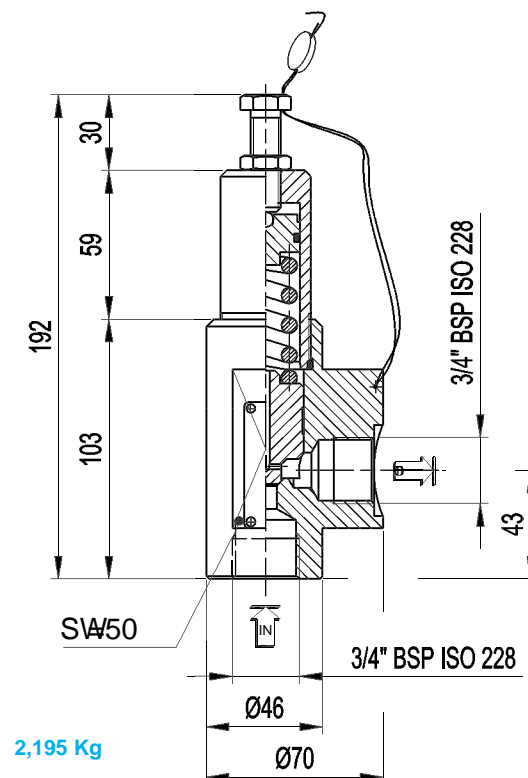
1	2	3	4	5
VS	224	T	X	/ 360

1	Series
Safety valves	= VS
2	Model
Model	= 224
3	Sealing material
Delrin	= T

5	Pressure setting (P)
10 ÷ 360 bar	= upon request
4	Body material
Stainless steel AISI316L	= X

Special variants upon request

8.1.7 DIMENSIONS



2,195 Kg

8.1c

8.1.8 EUROPEAN MARKET

Directive 97/23/EC provides that pressure equipment, in which it's reasonably expected to be exceeded the allowable limits, should be provided with adequate protective equipment; for example, safety accessories such as safety valves type VS or burst disk type DR (see Chap. 8.2). These devices shall prevent that pressure permanently exceeds the maximum allowable pressure PS of the equipment protected by them.

However, it is permissible a pressure peak of short duration limited to 10% of the maximum allowable pressure.

For the choice and sizing of the adequate safety device, the user should refer to specific standards.

In accordance with the regulations 97/23/EC, the safety valves are classified in Category IV.

8.1.9 ACCESSORIES

Two-way shut-off valves, see Chap. 8.4

Three-way shut-off valves, see Chap. 8.5

Gas side dumpers, see Chap. 8.3

8.1.10 COMMISSIONING AND MAINTENANCE

Installing the valves

Regarding the installation of the safety valves, you should be kept in mind the following key points:

- the safety valves must be installed in the area that need to be protected from overpressure in the vertical position with the inlet connection facing down;
- the vessels, connected each other by appropriate piping with a diameter adapted by the Manufacturer and User and on which there weren't interposed interceptions, can be considered for the installation of the safety valves, as a single vessel;
- the connection between the valve and the equipment to be protected should be as short as possible and must not have a cross section smaller than the one of the valve inlet. In any case, the standard EN 13136:2001/A1: 2005 states that the pressure drop between the protected vessel and the safety valve, at flow rate of full discharge, should not exceed 3% of the pressure value P, including any accessory inserted on the line;
- the choice of the safety valve displacement should consider that the operation of the valve results in the discharge of the gas under pressure, if not sent directly to atmosphere.

Where there is a risk of causing direct damage to individuals who are nearby, you will have to provide a pipe for conveying the discharge, sized so as not to affect the operation of the valve.

Standard EN 13136:2001/A1: 2005 requires that this pipeline should not generate, at full capacity, a pressure higher than 10% of the value of the calibration pressure for conventional unbalanced valves.

Disassembly

Before removing the valve, make sure that the plant on which it is mounted is not under pressure and that there is no pressure within the valve.

Ordinary maintenance

Checking the seals of the shutter and the seat on the system at each opening of the valve or every 6 months of operation. Periodic retest

according to the related standards of the country of installation. In Italy, see the Ministerial Decree 329 dd. 12/01/2004: for fluids of the group 1: every 2 years you must carry out a functional test and every 10 years you must check the integrity; for fluids of the group 2, every 3 years, you must check the operation and every 10 years you must check the integrity.

8.1.11 SIZING

Calculation according to ISO 4126-6

$$Q = C \cdot K_b \cdot \alpha \cdot A \cdot P \cdot \text{radp} (M/T \cdot Z)$$

Definitions

- A = mm² Minimum cross sectional flow area
- Q = Kg/h Mass flow rate
- P = bar abs Relieving pressure (= barg + 1.013)
- K = Isentropic exponent
- C = Function of isentropic exponent (=2.401 for k=1)
- A = Discharge coefficient (0.95)
- T = °K Relieving temperature
- Z = Compressibility factor
- M = Kg/Kmol Molecular factor
- K_b = Capacity correction factor for subcritical flow
- P_b = bar abs Back pressure

Examples

Gas: Nitrogen N₂

PRESS. SETTING 330 BAR	
DN	9.5 mm
A	70
P _b	1.013 bar abs
P _s	330 bar g
P	331.013 bar abs
T _s	80°C
T	353°K
M	29
Z	1
C	2,703
A	0,95
K _b	1

Mass flow rate calculation Q = 17,000 Kg/h

PRESS. SETTING 360 BAR	
DN	9.5 mm
A	70
Pb	1.013 bar abs
Ps	330 bar g
P	331.013 bar abs
Ts	80°C
T	353°K
M	29
Z	1
C	2,703
A	0,95
Kb	1

Mass flow rate calculation $Q = 18,600 \text{ Kg/h}$

8.1.12 EXAMPLES OF SAFETY VALVE ASSEMBLY

Direct mounting on a bladder accumulator



Direct mounting on a piston accumulator with nipple of 3/4" BSP



Mounting with shut-off 2-way valves (Chap. 8.4) to avoid discharging all the nitrogen in case of retest on the working bench or maintenance to the valve.



8.1f

Mounting with 3-ways shut-off valves (Chap. 8.5) to continue working safely with the second valve when it is necessary to remove the first for retesting on the working bench or maintenance.



8.1g

8.1d

8.1e

Reproduction is forbidden.

In the spirit of continuous improvement, our products may be changed.

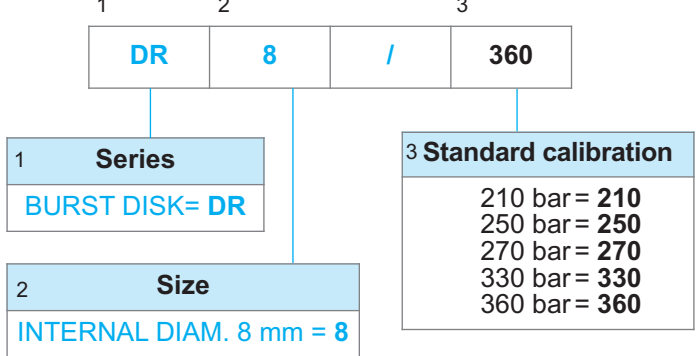
8.2.1 TECHNICAL DATA

- INTERNAL DIAMETER: 8 mm
- INFLUX DIAMETER: 4
- MAX OPERATING PRESSURE: 400 BAR
- OVERPRESSURE: 0 + 10%
- WORKING TEMPERATURE: -40°C +150°C
- TESTING CERTIFICATE: CE/PED (97/23/EC)
- CALIBRATION ERROR: <3%
- OVERPRESSURE BY FULL FLOW: 10% of P
- MATERIAL: stainless steel AISI 316L
- MEDIUM: nitrogen (N2)
- WEIGHT: see table 8.2c

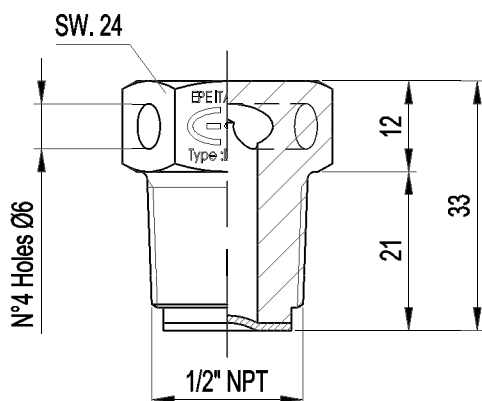
8.2.2 DESCRIPTION

The BURST DISK is a safety device that can be mounted on the gas side of the bladder and piston accumulators. Its function is to protect the accumulator from any excessive pressure that may exceed the maximum design limit of the accumulator itself causing damages to equipment and people. The rupture of the disk is a drastic measure; in fact you will assist to the full release of all the contents of the accumulator (nitrogen). Reaction to end of overpressure: it does not close, and then the disk must be replaced. The burst disk is composed of a properly drilled hexagonal cap in stainless steel AISI 316L on which it is brazed a calibrated and concave membrane, which will explode at the pre-set value. It can be installed in any position.

8.2.3 ORDER CODE



8.2.4 DIMENSIONS

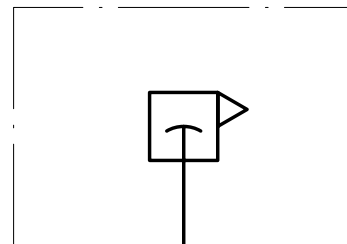


8.2c



8.2a

8.2.5 HYDRAULIC SYMBOL



8.2b

8.2.6 ACCESSORIES

For adapter, see Section 8.3

8.2.7 EUROPE MARKET

All burst disk cure the safety device Certification: CE/PED
 Periodic check of calibration: is not required in accordance with Ministerial Decree No. 329.

8.2.8 SIZING

Mass flow for glass (Nitrogen)
 Calculation according to ISO 4126-6
 Equation 6c $Q = C \cdot K_b \cdot \alpha \cdot A \cdot P \cdot \text{radp} \text{ (M/T}^2\text{)}$

Fixed setting (std)	210 bar = 210
	250 bar = 250
	270 bar = 270
	330 bar = 330
	360 bar = 360

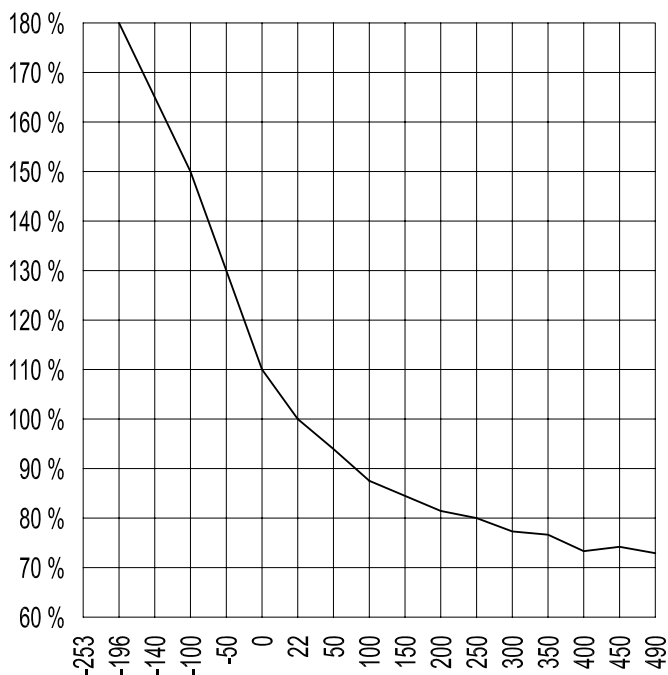
Definitions

- A = mm² Minimum cross sectional flow area
- Q = Kg/h Mass flow rate
- P = bar abs Relieving pressure (=barg + 1.013)
- K = Isoentropic exponent
- C = Function of isoentropic exponent (=2.401 for k=1)
- A = Discharge coefficient (0.62 – 0.80)
- T = °K Relieving temperature
- Z = Compressibility factor
- M = Kg/Kmol Molecular factor
- K_b = Capacity correction factor for subcritical flow
- P_b = bar abs Back pressure

Calculation example

PRESS. SETTING 330 BAR	
DN	8 mm
A	50
Pb	1.013 bar abs
Ps	330 bar g
P	331.013 bar abs
Ts	80°C
T	353°K
M	29
Z	1
C	2,703
A	0,62
Kb	1

In the selection of the range of burst disk, it must be remembered that the nominal setting pressure has a tolerance 0 +10% and the burst pressure varies according to the temperature as shown below.



8.2d

8.2.9 FUSE DISK

Temperature fuses are "devices with a safety function" and are used to release the gas pressure by discharging the nitrogen completely when a rise in temperature reaches unacceptable levels (i.e. in the case of fire).

Permitted operation pressure: ≤ 500 bar

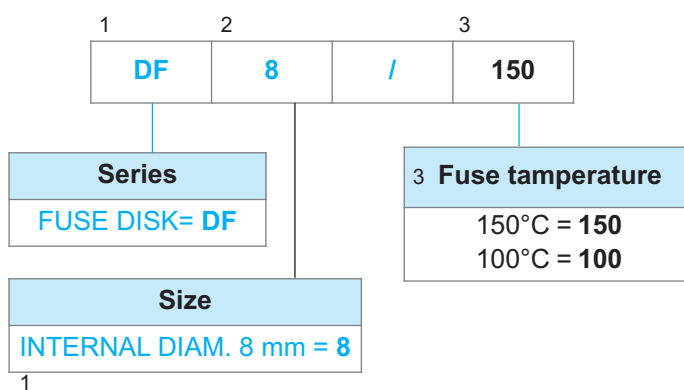
Temperature range: -10 °C ... $+80$ °C

Melting point: Approx. 150 °C

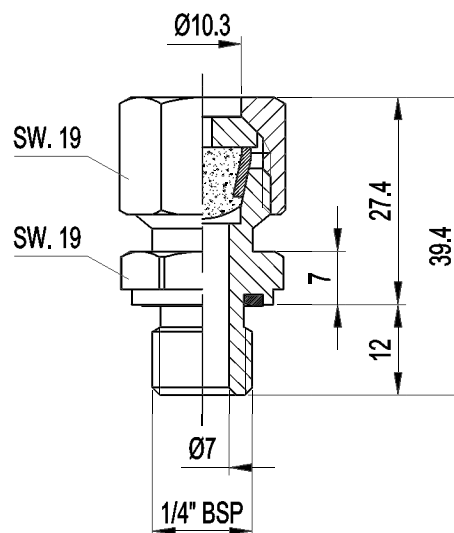
Installation:

Simple to retrofit by replacing the sealing cap with the temperature fuse.

8.2.10 ORDER CODE OF THE FUSE DISK



8.2.11 FUSE DISK DIMENSIONS



8.2e

Reproduction is forbidden.

In the spirit of continuous improvement, our products may be changed.

8.3.1 TECHNICAL DATA

INTERNAL DIAMETER: 10 mm

MAX OPERATING PRESSURE: 400 BAR

WORKING TEMPERATURE: -20 ÷ 80 °C ("P" version with NBR seals)
-10 ÷ 150°C("V" version with VITON seals)

SAFETY VALVE: see catalogue section 8.1

BURST DISK: see catalogue section 8.2

FUSE DISK: see catalogue section 8.2

MATERIAL: - phosphated or
- galvanized carbon steel in compliance with Directive 2002/95/EC (RoHS) to resist to corrosion
- stainless steel AISI 316L
- nickel coating 25-40 µ

MEDIUM: nitrogen (N₂)

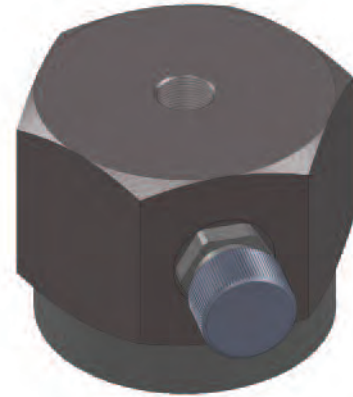
WEIGHT: see table 8.3c

8.3.2 ADVANTAGES

- compact design
- flexible connection options
- the accumulator can be charged with nitrogen using PC kit , directly via standard or special filling valve.

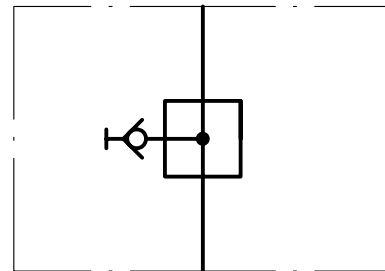
8.3.3 DESCRIPTION

The gas side adapters are blocks of various type, which is possible to mount on the gas side of an accumulator and which can be fit many pressure devices, charging equipment, gas safety valve, burst disk, fuse disk, needle valve, pressure gauge, minimess and other components. Special seal allows this adapter to be installed simply and securely in any position on all gas valves of the bladder accumulators. It's important to select the correct adapter based on the thread of the gas valve.



8.3a

8.3.4 HYDRAULIC SYMBOL



8.3b

8.3.5 MOUNTING

Before mounting a gas side supplied as individual item, you should fully discharge the nitrogen pressure inside the accumulator. The you should unscrew the existing pre-charge valve. External valve

Intenal valve

Use a wrench with code B2508

Now make sure the seal is correctly fitted into its seat inside the adapter on the threaded side

In order to mount the adapter on the valve of the accumulator, screw the adapter on the gas valve body of the accumulator and tighten with torque 80+20Nm.

If necessary, connect the various connections.

Pre-charge the accumulator as shown in the manual of use and maintenance.

8.3.6 ORDER CODE

1	2	3	4	5	6	7
TG	50	P4	V	-	1G2	- C P

1	Series
Gas side adapter	= TG

2	Gas valve dimension
M50X1.5 = 50	
M22X1.5 = 22	
7/8" UNF = 7/8	

3	Top central connection
1/2" NPT-F	= P4
3/4" BSP male	= G5M
1/2" BSP female	= G4
Burst disk set at xxx bar	= Rxxx
Safety valve set at xxx	= Gxxx
1/4" BSP female	= G2
Connection for pressure gauge of 1/4" BSP	= M000
Pressure gauge dia. 63 mm with full scale xxx	= Mxxx
Ball valve of 1/2" BSP	= B4
Needle valve of 1/4" BSP	= N2
Stainless steel needle valve of 1/4" BSP	= N2X
Stainless steel ball valve of 1/4" BSP	= B2X
Needle valve of 1/4" BSP + cap	= N2T
1/4" BSP Plug	= T2
1/2" BSP Plug	= T4
N°1 exclusion device at 90° with pressure gauge dia. 63 mm with full scale xxx	= ELMxxx

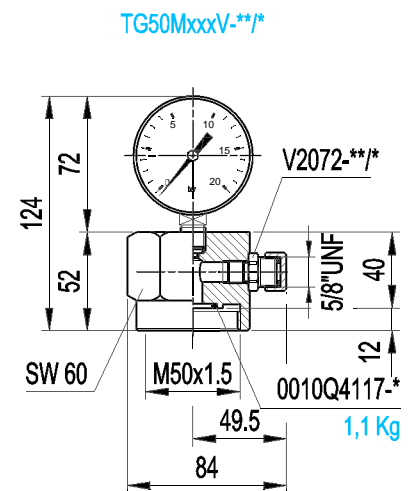
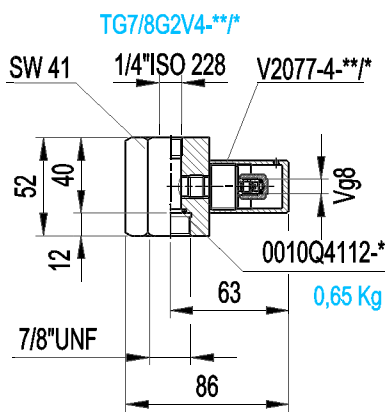
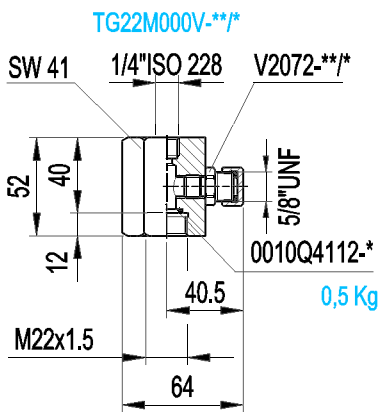
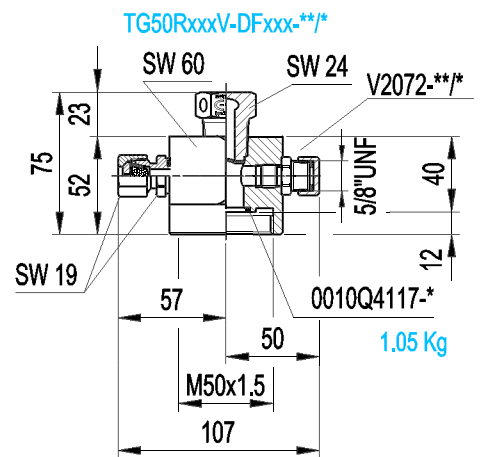
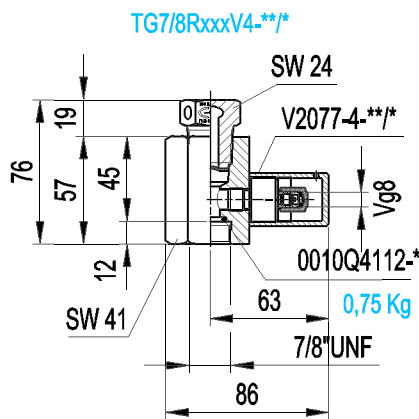
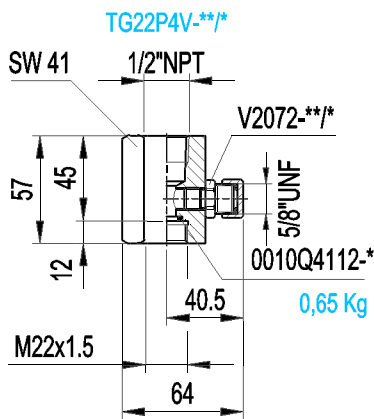
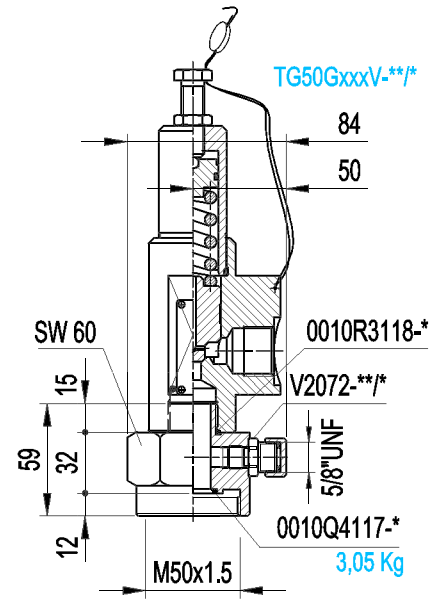
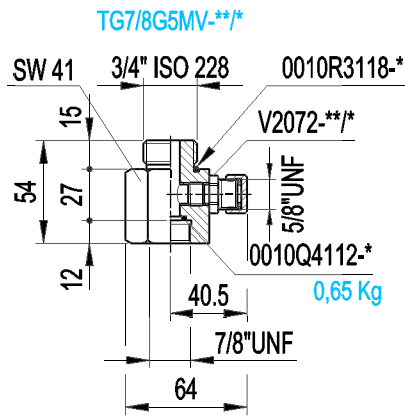
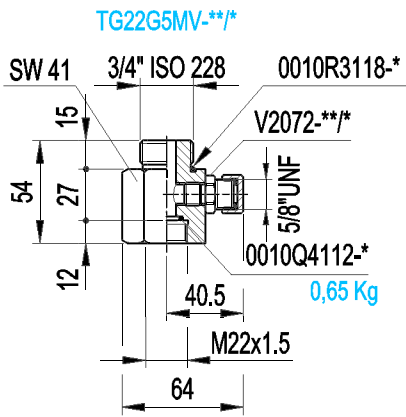
4	Pre-charge valve (Lateral)
Valve of 5/8" UNF	= V
Stainless steel valve of 5/8" UNF	= VX
Valve of 7/8" UNF	= V4
Valve of 1/4" BSP	= V2

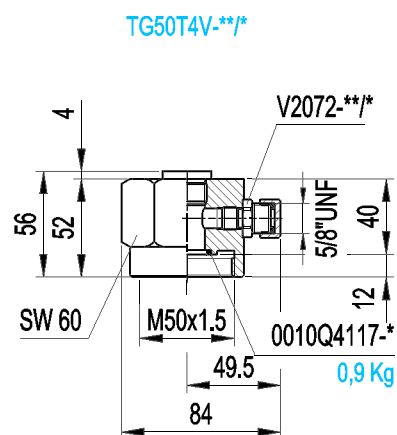
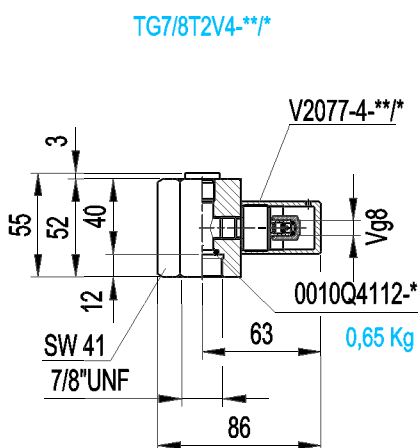
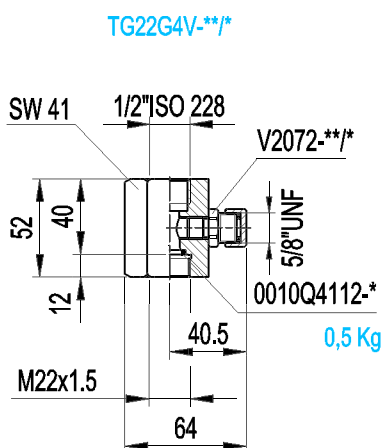
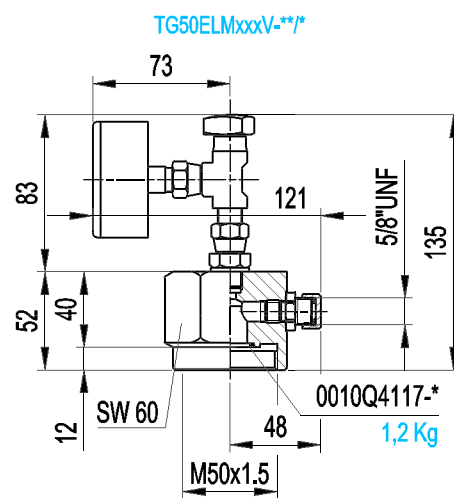
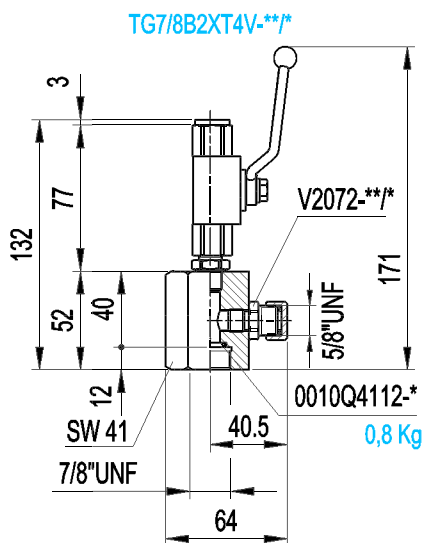
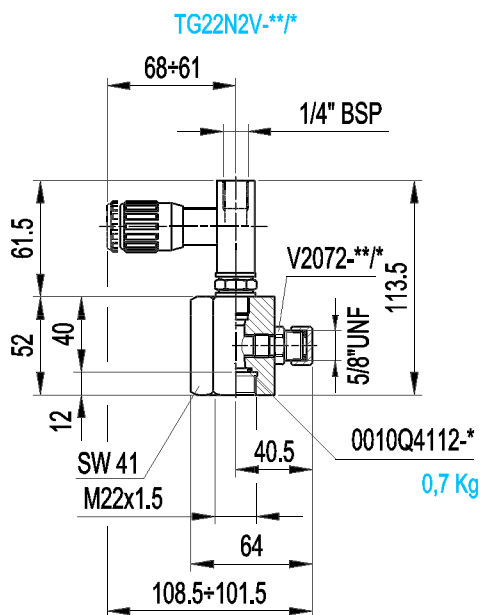
7	Seals material
Nitrile NBR	= P
Viton FKM	= V

6	Material
Carbon steel	= C
Nickel carbon steel 25 μ	= N
Nickel carbon steel 40 μ	= M
Stainless steel AISI 316 L	= X

5	Eventually lateral connections
No. 2 of 1/4" BSP	= 2G2
No. 3 of 1/4" BSP	= 3G2
No. 1 exclusion device with pressure gauge dia. 63 mm with full scale xxx	= 1EMxxx
No. 1 exclusion device at 90° with pressure gauge dia. 63 mm with full scale xxx	= 1ELMxxx
No. 1 of 1/4" NPT-F	= 1P2
No. 2 of 1/4" NPT-F	= 2P2
No. 3 of 1/4" NPT-F	= 3P2
No. 1 needle valve of 1/4" BSP	= 1N2
No. 1 stainless steel ball valve of 1/4" BSP	= 1B2X
No. 1 needle valve of 1/4" BSP + cap	= 1N2T
Fuse disk at xxx°C	= DFxxx

8.3.7 DIMENSIONS





Reproduction is forbidden.

In the spirit of continuous improvement, our products may be changed.

8.4.1 TECHNICAL DATA

MAX OPERATING PRESSURE: 320 bar

MINIMUM DIAMETER: 19 mm

CONNECTIONS: 3/4 BSP UNI/ISO 228

WORKING TEMPERATURE: -20 ÷ 100

FLUID VISCOSITY RANGE: 10 ÷ 400 cSt

RECOMMENDED VISCOSITY: 36 cSt

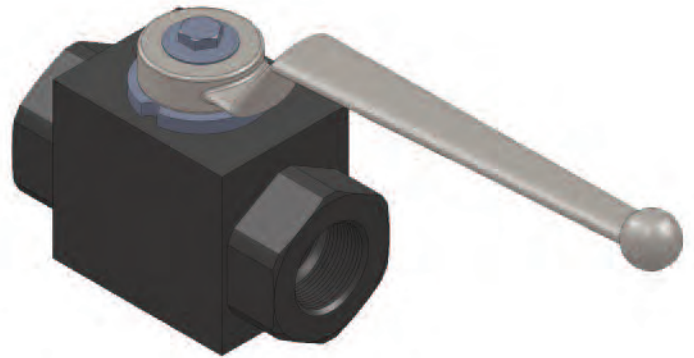
FLUID CONTAMINATION DEGREE:
class 20/18/15 according to ISO 4406/99

BODY MATERIAL: phosphated carbon steel

BALL: in chromed thick steel

SEALS: polyacetal resin and NBR

LEVER: zinc-stamped

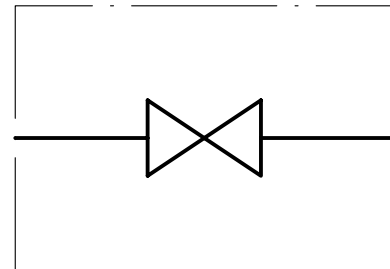


8.4a

8.4.2 DESCRIPTION

The two-way ball valve is used to detect the safety valve type VS224 and to remove it for periodic recalibration, without having to fully discharge all the nitrogen of accumulator / accumulator station. The ball of the valve is located between two pre-compressed seals provided with a floating system, so it is guaranteed a perfect seal at both low and high pressure.

8.4.4 HYDRAULIC SYMBOL



8.4b

8.4.3 ORDER CODE

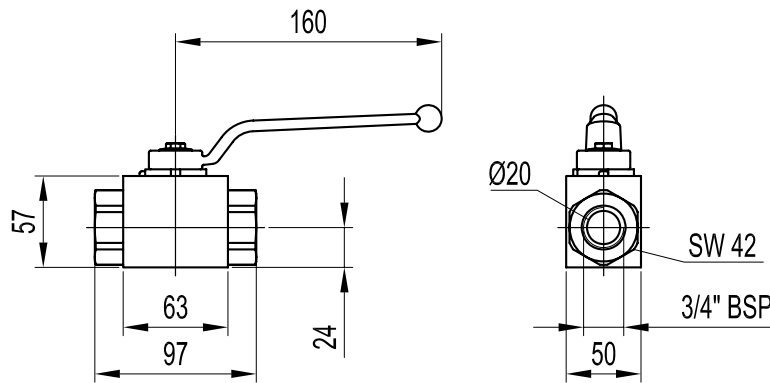
1	2	3
B2459	/	05
		K

1	Series
	Shut off 2-way valves gas side = B2459

2	Size
	Connection of 3/4" BSP = 5

3	Variants
	Version with padlock = K
	Plumbing of the handle in one of two positions = PB

8.4.5 DIMENSION



8.4c

8.4.6 CHARACTERISTIC CURVES

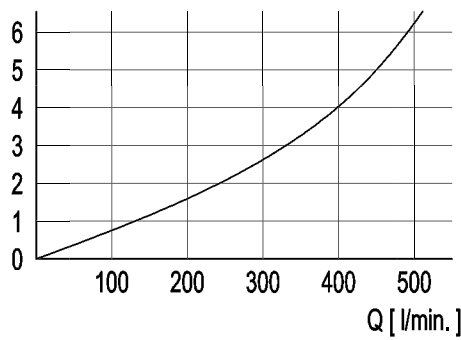
Measured with viscosity of 36 cSt at 50°C.

ΔP Curves

Flow rate of shut off valve

B 2459

ΔP
[bar]



8.4d

Reproduction is forbidden.

In the spirit of continuous improvement, our products may be changed.

8.5.1 TECHNICAL DATA

MAX OPERATING PRESSURE: 320 bar

MINIMUM DIAMETER: 19 mm

CONNECTIONS: 3/4" BSP UNI/ISO 228

WORKING TEMPERATURE: -20 ÷ 100

FLUID VISCOSITY RANGE: 10 ÷ 400 cSt

RECOMMENDED VISCOSITY: 36 cSt

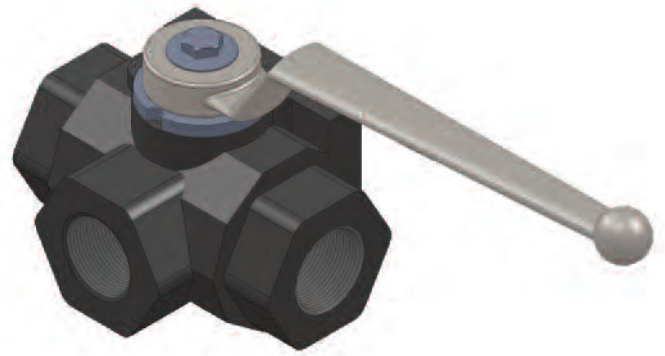
FLUID CONTAMINATION DEGREE:
class 20/18/15 according to ISO 4406/99

BODY MATERIAL: phosphated carbon steel

BALL: in chromed thick steel

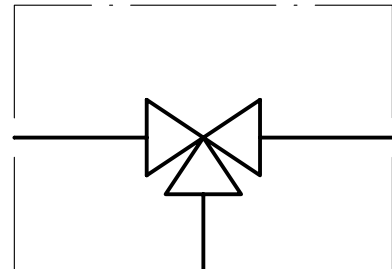
SEALS: polyacetal resin and NBR

LEVER: zinc-stamped



8.5a

8.5.4 HYDRAULIC SYMBOL



8.5b

8.5.2 DESCRIPTION

The three-way ball valve is used to mount two safety valves type VS224 and toggling the lever in a timely manner. You can also disassemble them once at a time for periodic recalibration, always having the system in safety, protected by at least one valve. In fact, the central transitory of the valve connects both valves with the system.

The ball of the valve is located between two pre-compressed seals with a floating system, so it is guaranteed a perfect seal at both low and high pressure.

8.5.3 ORDER CODE

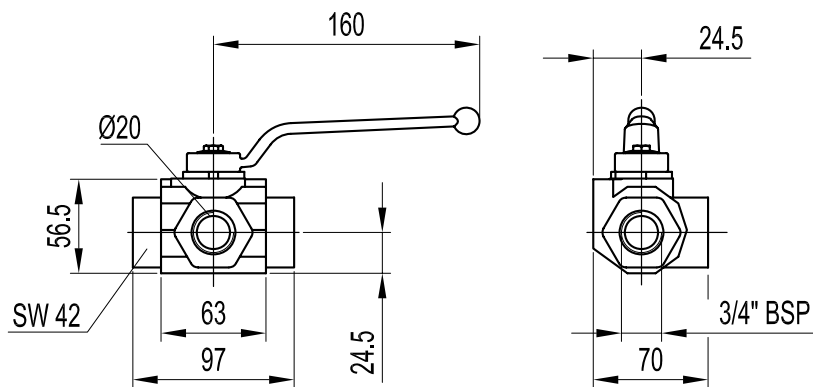
1	2	3
B2460	/	05
		K

1	Series
	Shut off 3-way valves gas side = B2460

2	Size
	Connection of 3/4" BSP = 5

3	Variants
	Version with padlock = K
	Plumbing of the handle in one of two positions = PB

8.4.5 DIMENSION



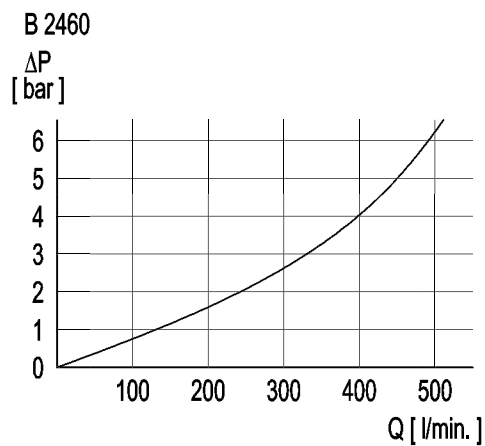
8.5c

8.5.6 CHARACTERISTIC CURVES

Measured with viscosity of 36 cSt at 50°C.

 ΔP Curves

Flow rate of shut off valve



8.5d

Reproduction is forbidden.

In the spirit of continuous improvement, our products may be changed.

8.6.1 TECHNICAL DATA

INTERNAL DIAMETER: 32 mm

MAX OPERATING PRESSURE: 400 BAR

WORKING TEMPERATURE:

-20 ÷ 80 °C ("P" version with NBR seals)

-10 ÷ 150°C("V" version with VITON seals)

SAFETY VALVE: see catalogue section 8.1

BURST FUSE DISK: see catalogue section 8.2

MATERIAL: - phosphated or
 - galvanized carbon steel in compliance
 with Directive 2002/95/EC (RoHS)
 to resist to corrosion.
 - stainless steel AISI 316L
 - nickel coating 25-40 μ

WEIGHT: see table 8.6c

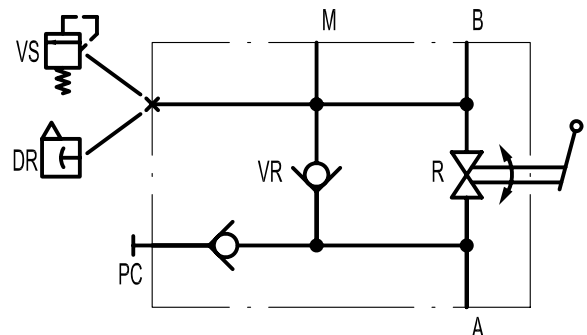


8.6a

8.6.2 DESCRIPTION

Accumulator charging and shut-off safety block type BC is used in order to make safer and more practical the connection of one or more additional nitrogen cylinders with a bladder (transfer version "AST") or a piston accumulator. It includes the filling valve to charge and test the pre-charge of the accumulator through pre-loading set PC (see catalogue Section 10). In addition, it allows the additional nitrogen cylinders to be shut-off from the (bladder or piston) accumulator. The check valve guarantees the nitrogen passage from the accumulator to the cylinders even when the ball valve is closed. It is possible to connect directly a safety valve or a burst/fuse disk. Also it has two connections for pressure gauge / pressure transmitter / pressure plugs Minimes or needle-valve. When the shut-off valve remains open during the operation in order to assure the free nitrogen flow between cylinders and accumulator and vice versa, it should be closed only for a check or for the accumulator maintenance or for use the accumulator as pump for filling the cylinders/accumulation station.

8.6.3 HYDRAULIC SYMBOL

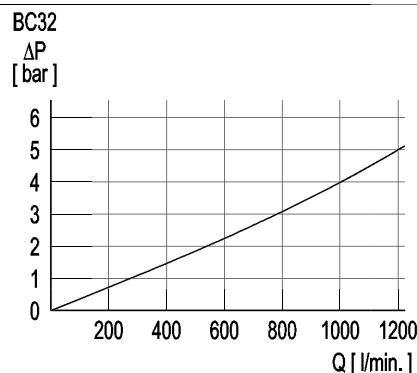


8.6b

8.6.4 CHARACTERISTIC CURVES

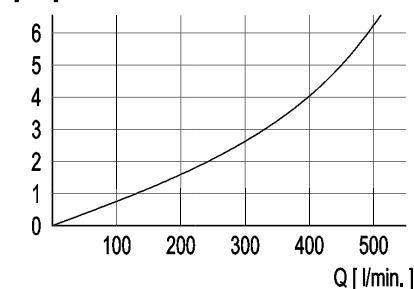
ΔP Curves

Flow rate from A to B and viceversa



Flow rate from to A and B close to VR

BC32 non-return valve
 ΔP [bar]



8.5d

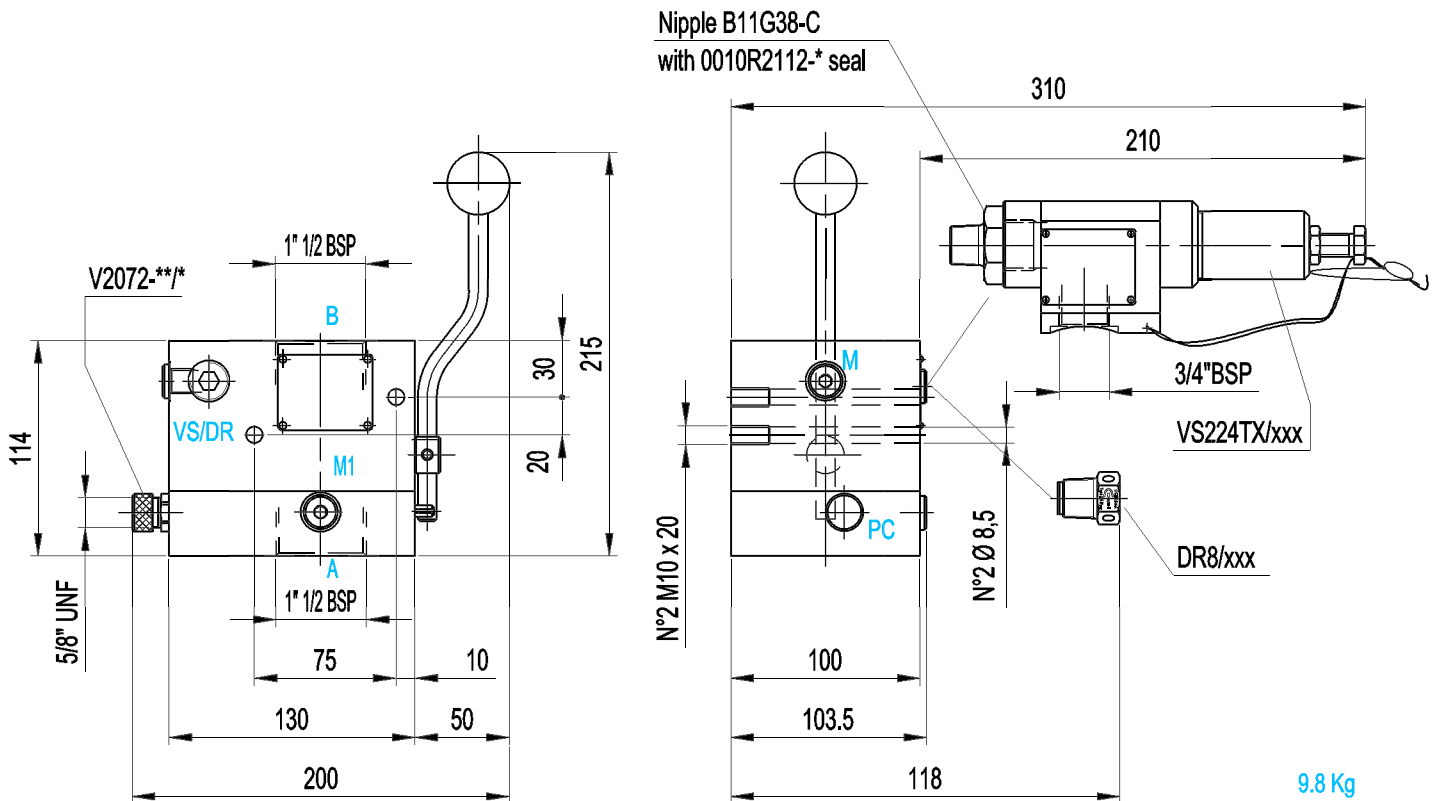
8.6d

8.6.5 ORDER CODE

1	2	3	4	5	6	7	8	9	10	
BC	32	R	210	G8	G8	V	8	-	C	P

1 Series Charging and shut-off safety block = BC	10 Seals material Nitrile NBR = P Viton FKM = V
2 Internal nominal diameter 32mm = 32	9 Body Material Carbon steel = C Nickel 25 μ = N Nickel 40 μ = M Stainless steel AISI 316 L = X
3 Safety accessory Connection 1/2" NPT-F (with a plastic cap) = A Fuse disk = F Safety valve type VS224TX = G Burst disk = R Connection 1/2" NPT-F with closing cap) = T	8 Certifications 97/23/EC = 8 TR (Russia) = 1 Passport (Ukraine) = 11
4 Calibration of the safety valve See Section 8.1 or 8.2 = 5 ÷ 360	7 Filling valve 5/8" UNF (std) = V 5/8" in stainless steel = VX 7/8" UNF = V4 1/4" BSP = V2
5 Accumulator side connection 1"1/2 BSP ISO 228 = G8	6 Bottle side connection 1"1/2 BSP ISO 228 = G8

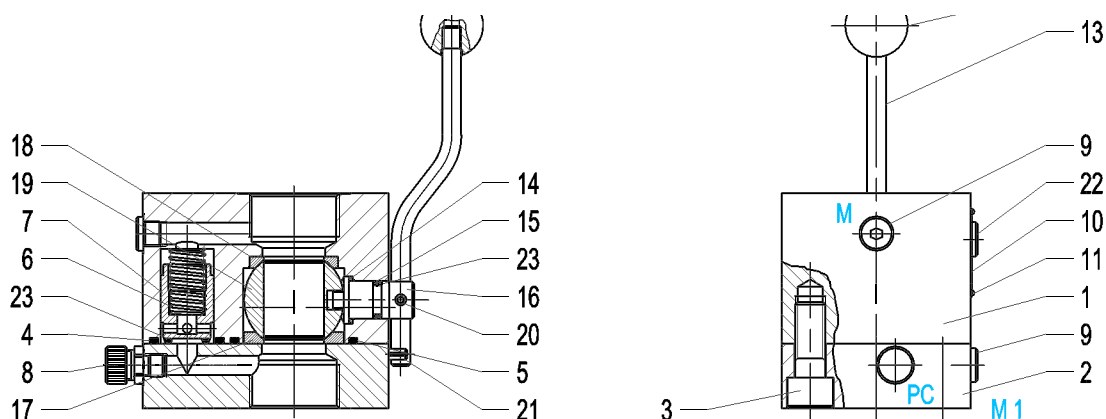
8.6.6 DIMENSIONS



8.6e

- M = 1/4" BSP
- M1 = 1/4" BSP
- VS/DR = 1/2" NPT
- A = 1" 1/2 BSP Accumulator connection
- B = 1" 1/2 BSP Bottle connection
- PC = 5/8" UNF

8.6.7 SPARE PARTS CODES



8.6f

8.6f

Item	Description	Q.ty	Order code
1	Safety block BC32	1	Not supplied as spare part
2	Plate of closing	1	Not supplied as spare part
3	Hex, socket head cap screws M16x40 UNI5931	6	0022VTCEIM16x40-C2
4	"O" ring	1	0010R4131 - *
5	"O" ring	1	0010R0164 - *
6	Spring	1	B10149 - X
7	Nozzle	1	B11637 - CP
8	Standard gas valve assembly	1	V 2072 - ** / *
9	Plug with rubber seals 1/4" BSP	2	0031TG2-CP
10	Plate for block	1	B11024 - 6 - A
11	Hammer rivet	4	0029R1,9x5-C
12	Knob M10	1	0055P5,35-M10-EA
13	Handle	1	B10482 - C
14	Seal for pin	1	B10487 - D
15	"O" ring	1	0010R0119 - *
16	Pin	1	B10480R - C
17	Gasket for ball 52.7x6	1	0013913815-RN
18	Gasket for ball 46.5x6	1	0013G913813-RN
19	Ball DN32	1	0052S907344-RN
20	Set screw M6x8 UNI 5927-67	1	0022VSTEIM6x8-CZ
21	Spring pins 6x26 UNI 6873	2	0023E6x26-C
22	Plug 1/2" NPT	1	0031TP4
23	Antiextrusion ring Parbak	1	0011P8113 - *
	Gasket sets	1	B2371-* { 0010R4131-* 0010R0164-* B10487-D 0010R0119-* 0010P8113-*
	Ball sets	1	B2135-* { 0013913815-RN 0013G913813-RN 0052S907344-RN

* Gasket material ** Component material

8.6g

Reproduction den.

8.6g

In the spirit of continuous improvement, our products may be changed.

Reproduction is forbidden.

In the spirit of continuous improvement, our products may be changed.



FLUID SAFETY VALVES type DBDS

9.1



BLOCKS FOR RELIEF VALVE type BPV and BAPV

9.2



SAFETY BLOCK type BS

9.3



FLUID SIDE ADAPTERS type TF

9.4

9.1.1 TECHNICAL DATA

MAX OPERATING PRESSURE (PS): sizes 6, 20: 400 bar
 size 10: 630 bar
 size 30: 315 bar

PRESSURE SETTING (P): (upon request)
 sizes 6, 20: $6 \div 400$ bar
 size 10: $6 \div 630$ bar
 size 30: $30 \div 315$ bar

NOMINAL SIZE: 6, 10, 20, 30

LIFT: 2 mm

WORKING TEMPERATURE: $-20 \div +150$ °C

REPETIBILITY: $\pm 3\%$ of P

CALIBRATION ERROR: 3%

OVERPRESSURE BY FULL FLOW: 10% of P

BLOW DOWN: 10% of P

FLUID VISCOSITY RANGE: $10 \div 400$ cSt

RECOMMENDED VISCOSITY: 36 cSt

FLUID CONTAMINATION DEGREE:
 class 20/18/15 according to ISO 4406/99

BODY MATERIAL: - phosphated carbon steel or galvanized carbon steel
 in compliance with Directive 2002/95/EC (RoHS) to resist to corrosion.
 - stainless steel (only DBDS 10 K)

SEALING MATERIAL: - **P** = Nitrile rubber (NBR)
 - **V** = Fluorocarbon (FPM)

CONNECTIONS: see Table 9.1d

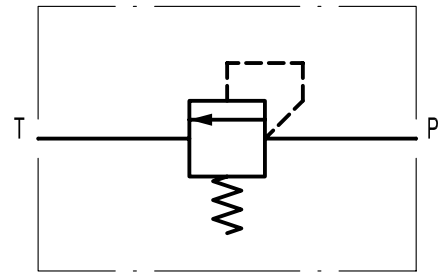
FLOW RATE: see Table 9.1d

WEIGHT: see Table 9.1d



9.1a

9.1.2 HYDRAULIC SYMBOL



9.1b

9.1.3 DESCRIPTION

Valves DBDS type are pressure direct command relief valves. Their function is to limit the pressure of a hydraulic system. The calibration of the system pressure is carried out continuously through the calibration device, which, by the spring, pushes the wedge against the seat.

The P channel is connected to the pressure line of the system, entering the valve, and acts on the active area of the wedge (or of the ball for the DBDS 10 at 630 bar).

When the pressure in channel P exceeds the value set on the spring, the wedge or the ball raises in contrast to the spring. The fluid now flows from the channel P to the channel T. The stroke of the wedge is limited by a pin in the damping chamber.

To obtain a good resolution of the pressure setting from 0 to 400 (630) bar, this has been divided into 7 pressure ranges. Each range has a specific spring for adjusting a maximum working pressure.

9.1.4 STRUCTURE

Body: in high strength steel, obtained by mechanical processing, in which are obtained the seats.

Poppet: obtained by mechanical processing from bar, it ensures the necessary seal degree on the valve seat. The poppet is well led by the damping piston and pushed by the spring against the seat.

Spring: it counteracts the pressure and the dynamic actions of the fluid and always ensures the closing of the valve after the discharge. The

coils of the spring, even when the obturator has reached its maximum lift, are never at pack.

The poppet has a mechanical lock and when it has reached it, the arrow of the spring does not exceed 85% of the maximum deviation.

Calibration system: threaded hexagon head screw which screws into the top of the valve by compressing the spring below. After the calibration, the position of the adjusting screw is kept unaltered by locking the counter nut and sealing the adjusting screw (valve with EC/PED/EC certification).

9.1.5 CALIBRATION

All valves are calibrated on the working bench with a flow rate of 2 l / min. and with an atmospheric counter pressure. The repeatability error of calibration is less than 3% than the pressure P. Up to a pressure equal to 97% of the calibration pressure verifying that there's no leakages.

9.1.6 ORDER CODE

1	2	3	4	5	6	7	8	9			
DBD	S	10	K	13	/	360	-	8	-	C	P

1	Series
Fluid safety valves	= DBD

2	Type of adjustment
Size 6, 10, 20	
Hexagon socket set screw	= S
Rotary knob	= H
Size 30	
Hexagon socket set screw	= S

3	Nominal diameter
6 mm	= 6
10 mm	= 10
20 mm	= 20
30 mm	= 30

4	Type of connection
Screw cartridge valve	= K
Threaded connection	= G
Sub-plate mounting	= P

5	Series number	5
Overall and mounting dimensions remain unchanged from 10 to 19.		

9	Sealing material
Nitrile (NBR)	= P
Viton (FKM)	= V

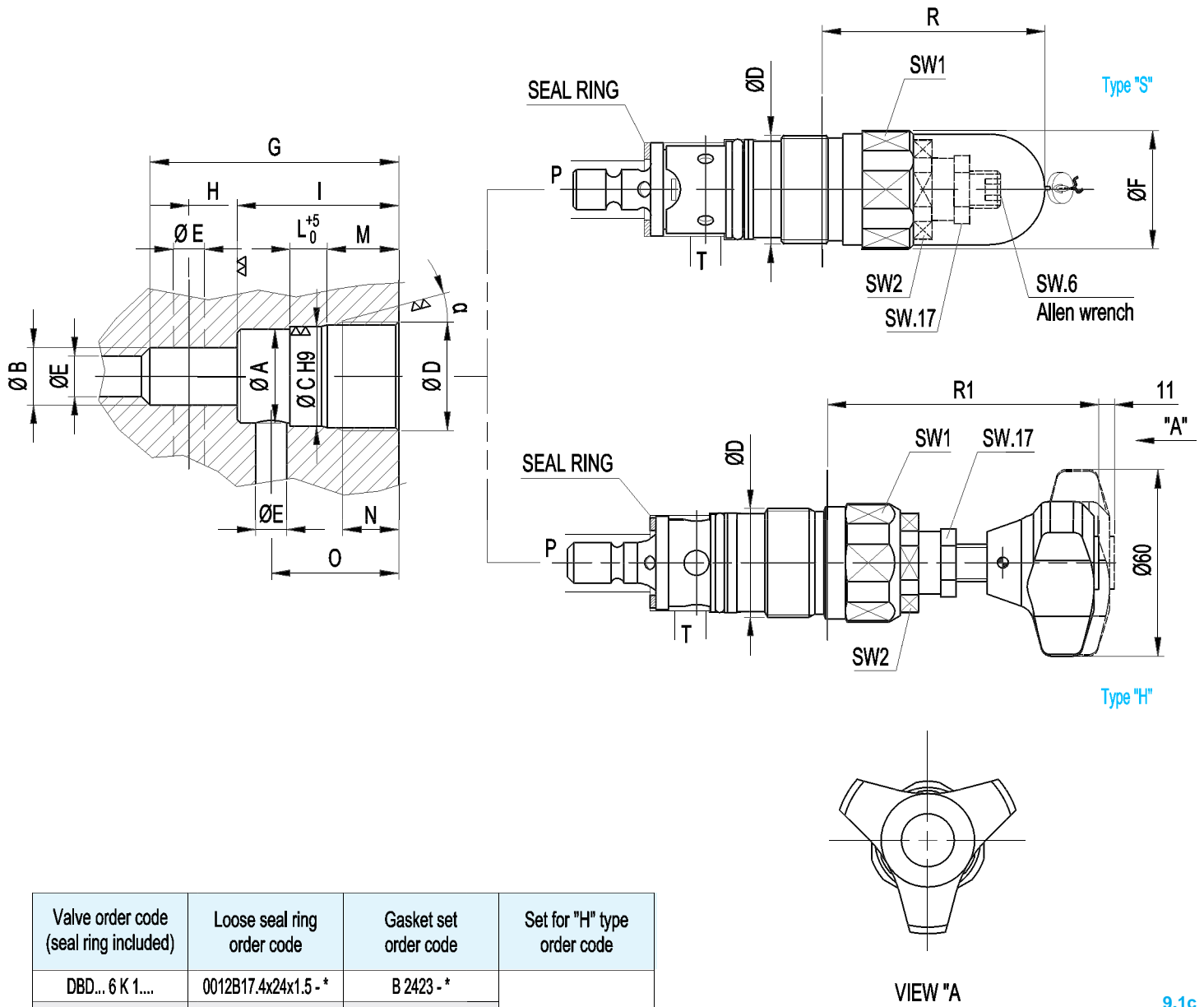
8	Body material
Carbon steel	= C
Stainless steel	= X

7	Certification
Without certification	= 0
TR (Russia)	= 1
PED 97/23/EC	
ATEX 94/9EC	= 9

Fixed Pressure setting (with certifications)	
DBDS6	6 ÷ 400 : upon request
DBDS10	6 ÷ 400 : upon request
DBDS20	6 ÷ 630 : upon request
DBDS30	30 ÷ 315 : upon request

6 Pressure rating (without certification)	
DBDS6	up to 25 : 25
	up to 50 : 50
	up to 100 : 100
	up to 200 : 200
	up to 315 : 315
	up to 400 : 400
DBDS10	up to 25 : 25
	up to 50 : 50
	up to 100 : 100
	up to 200 : 200
	up to 315 : 315
	up to 400 : 400
DBDS20	up to 25 : 25
	up to 50 : 50
	up to 100 : 100
	up to 200 : 200
	up to 315 : 315
	up to 400 : 400
DBDS30	up to 200 : 200
	up to 315 : 315

9.1.7.1 "K" VERSION DIMENSIONS



Valve order code (seal ring included)	Loose seal ring order code	Gasket set order code	Set for "H" type order code
DBD... 6 K 1....	0012B17.4x24x1.5 - *	B 2423 - *	B 2427
DBD... 10 K 1....	0012B24.7x31x2 - *	B 2424 - *	
DBD... 20 K 1....	0012B31x39x2 - *	B 2425 - *	
DBD... 30 K 1....	0012B42x52x3 - *	B 2426 - *	

* Gasket material

9.1d

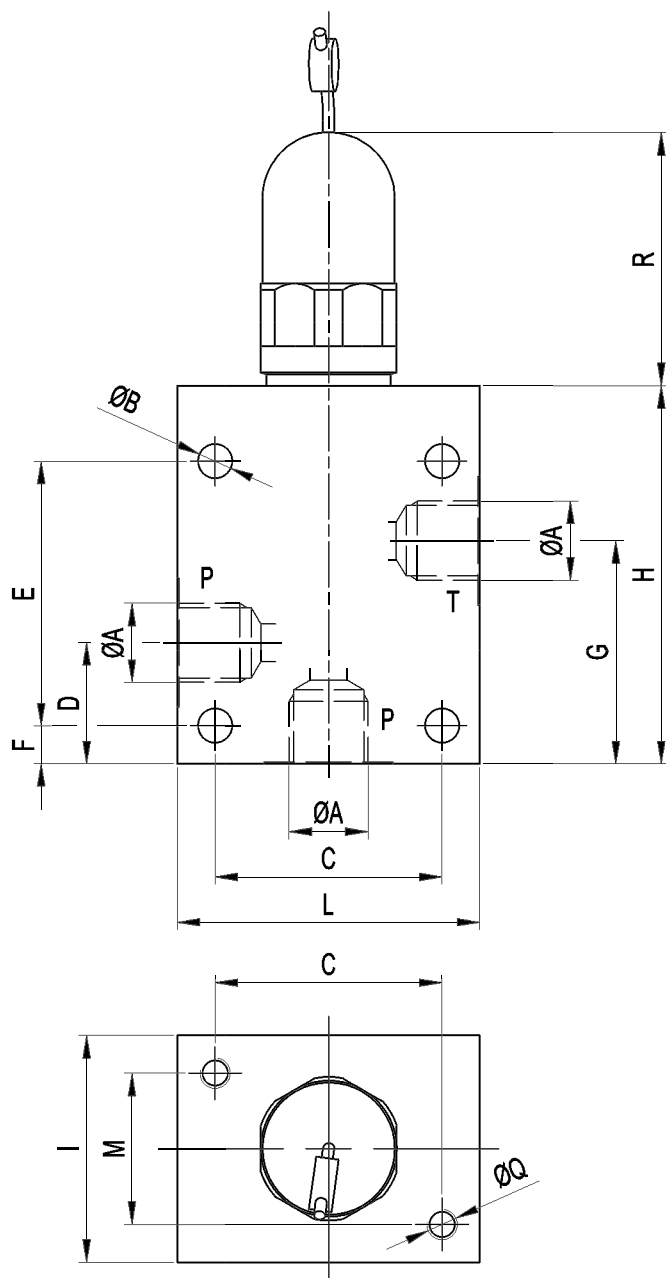
9.1c

Valve order code (seal ring included)	Ø A mm	Ø B mm	Ø C mm	Ø D	Ø E mm	Ø F Type S mm	G mm	H mm	I mm	L mm	M mm	N mm	O mm	R S type mm	R1 H type mm	SW1 mm	SW2 mm	α	Weight Kg
DBD... 6 K 1....	Ø24.9	15	Ø25 H9	M28x1.5	6	34	65	11.5±5.5	45	11	19	15	36	72	83	32	30	15°	0.36
DBD... 10 K 1....	Ø31.9	18.5	Ø32 H9	M35x1.5	10	38	80	15.5±7.5	52	12	23	18	41.5	68	79	36	30	15°	0.48
DBD... 20 K 1....	Ø39.9	24	Ø40 H9	M45x1.5	20	48	110	21.5±8.5	70	18	27	21	55	65	77	46	36	20°	0.86
DBD... 30 K 1....	Ø54.9	38.75	Ø55 H9	M60x2	30	63	140	29.5±11.5	84	16	29	23	63	83	-	60	46	20°	2

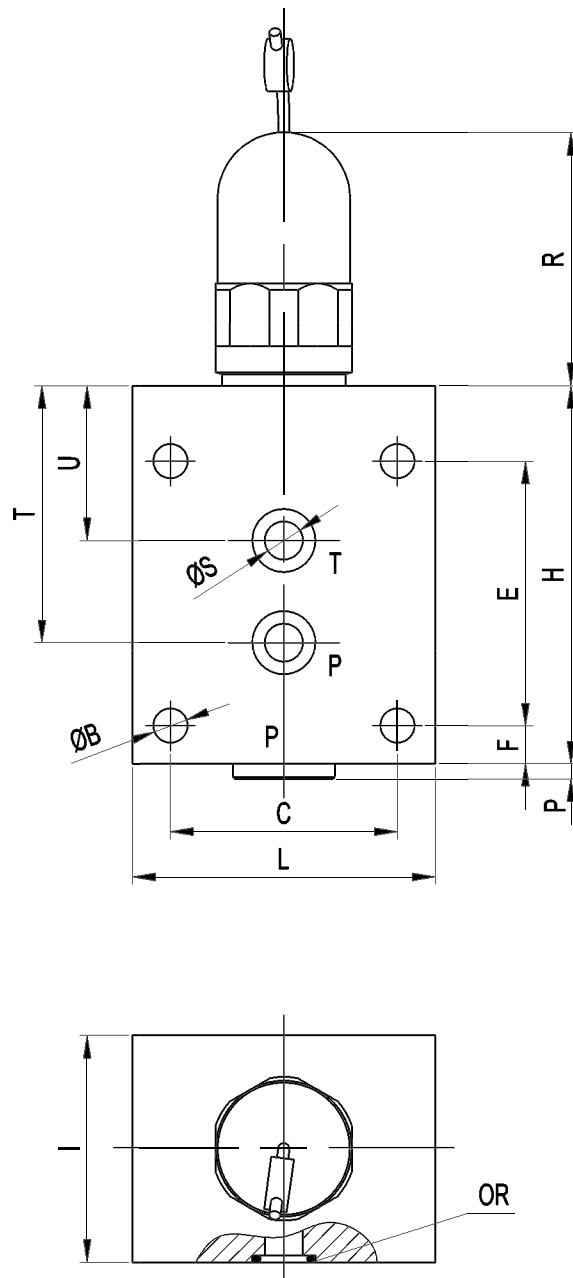
DBD... 30 K 1.... type "H" not available

9.1e

9.1.7.2 "G" & "P" VERSIONS DIMENSIONS



BLOCK "G" TYPE



BLOCK "P" TYPE

9.1f

Complete valve order code	Ø A BSP	Ø B mm	C mm	D mm	E mm	F mm	G mm	H mm	I mm	L mm	M mm	P mm	Ø Q mm	R mm	S mm	T mm	U mm	OR* metric	Weight Kg
DBDS6G1....	1/4"	6.6	45	25	55	10	45	80	40	60	25	4	M6	72	6	-	-	-	1.5
DBDS10G1....	1/2"	9	60	32	70	10	59	100	60	80	40	4	M8	68	10	-	-	-	3.7
DBDS20G1....	1"	9	70	50	100	15	81	135	70	100	50	5.5	M8	65	20	-	-	-	6.4
DBDS30G1....	1 1/2"	11	100	70	130	25	120	180	90	130	60	5.5	M10	83	30	-	-	-	13.9
DBDS6P1....	1/4"	6.6	45	25	55	10	45	80	40	60	25	4	M6	72	6	55	35	0010M7x1.5-*	1.5
DBDS10P1....	1/2"	9	60	32	70	10	59	100	60	80	40	4	M8	68	10	68	41	0010M12.3x2.4-*	3.7
DBDS20P1....	1"	9	70	50	100	15	81	135	70	100	50	5.5	M8	65	20	85	54	0010M22x3-*	6.4
DBDS30P1....	1 1/2"	11	100	70	130	25	120	180	90	130	60	5.5	M10	83	30	110	55	0010M22x3-*	13.9

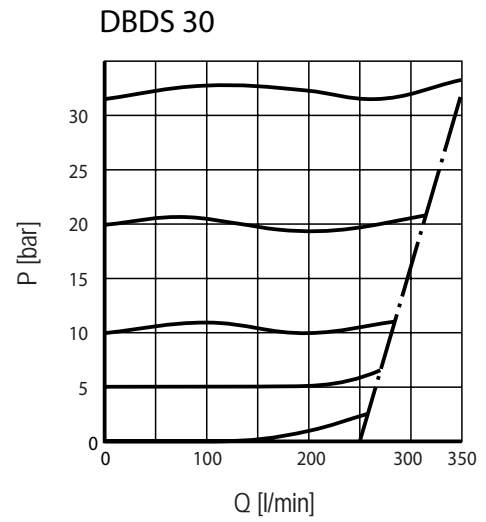
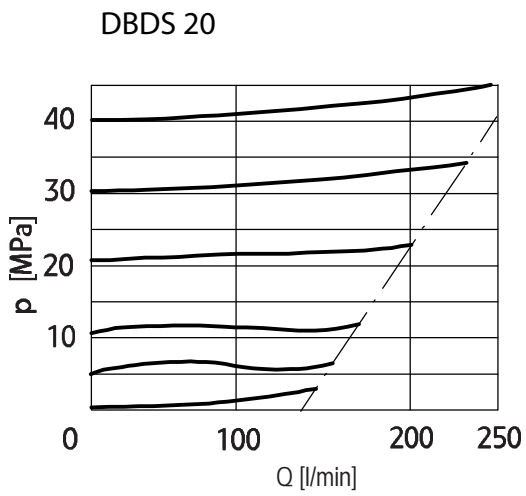
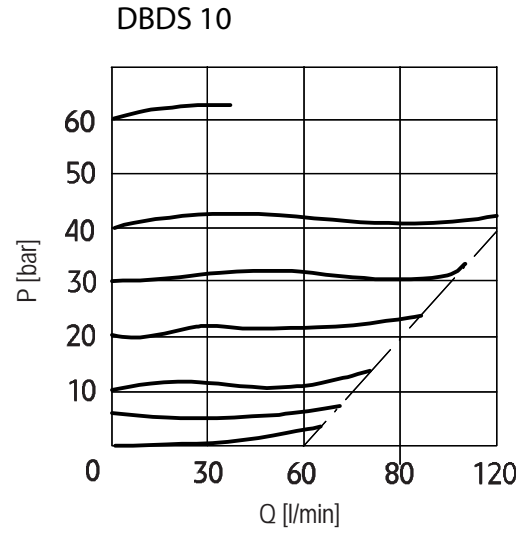
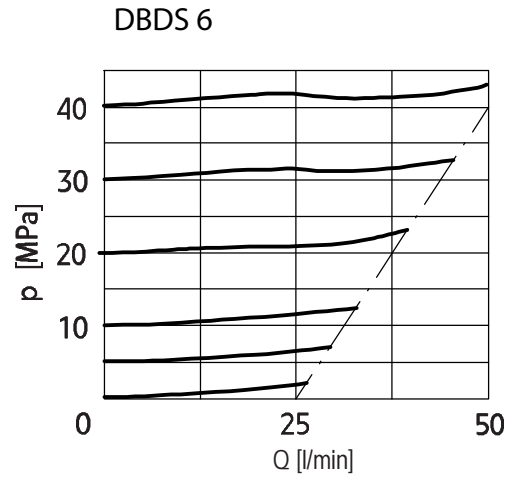
DBD... 30 K 1.... type "H" not available

* Gasket material

9.1g

9.1.8 CHARACTERISTIC CURVES

Measured with viscosity of 36 cSt at 50°C.



9.1h

9.1.9 EUROPEAN MARKET

Directive 97/23/EC provides that pressure equipment, in which it's reasonably expected to be exceeded the allowable limits, should be provided with adequate protective equipment; for example, safety accessories such as the valves DBDS "G"/ DBDS "P" or the safety blocks type BS. These devices shall prevent that pressure permanently exceeds the maximum allowable pressure PS of the equipment protected by them. However, it is permissible a pressure peak of short duration limited to 10% of the maximum allowable pressure. For the choice and sizing of the adequate safety device, the user should refer to specific standards. In accordance with the regulations 97/23/EC, the safety valves are classified in Category IV.

9.1.10 ACCESSORIES

Blocks for relief valves, see section 9.2

Safety blocks, see section 9.3

9.1.11 COMMISSIONING AND MAINTENANCE

Installing the valves

Regarding the installation of the safety valves, you should be kept in mind the following key points:

- safety valves must be installed in correspondence of the area to be protected by any overpressures; the vessels, connected each other by appropriate piping with a diameter adapted by the Manufacturer and User and on which there weren't interposed the interceptions, can be considered for the installation of the safety valves as a single vessel;
- the connection between the valve and the equipment to be protected

should be as short as possible and must not have a cross section smaller than the one of the valve inlet. In any case, the standard EN 13136:2001/A1: 2005 states that the pressure drop between the protected vessel and the safety valve, at flow rate of full discharge, should not exceed 3% of the pressure value P, including any accessory inserted on the line;

- the choice of the safety valve displacement should consider that the operation of the valve results in the discharge of the fluid under pressure to be sent into the tank. The discharging pipe must be sized as not to affect the operation of the valve. Standard EN 13136:2001/A1:2005 requires that this pipeline should not generate, at full capacity, a pressure higher than 10% of the value of the calibration pressure.

Disassembly

Before removing the valve, make sure that the system on which it is mounted is not under pressure and that there is no pressure within the valve.

Ordinary maintenance

Check the system in order to verify that there are no leakages of oil into the tank, with overheating of the assembly.

Periodic retest according to the related standards of the country of installation. In Italy, see the Ministerial Decree 329 dd. 12/01/2004: for fluids of the group 1: every 2 years you must carry out a functional test and every 10 years you must check the integrity; for fluids of the group 2, every 3 years, you must carry out a functional test and every 10 years you must check the integrity.

Reproduction is forbidden.

In the spirit of continuous improvement, our products may be changed.

9.2.1 TECHNICAL DATA

MAX OPERATING PRESSURE: 400 BAR

PRESSURE TEST: 1.43 X PS

NOMINAL SIZE: 6, 10, 20

BODY MATERIAL: galvanized carbon steel

SEALS MATERIAL: Nitrile (NBR)
Viton (FKM)

See Table 9.2c and or Section 1.8

WEIGHT: see Table 9.2

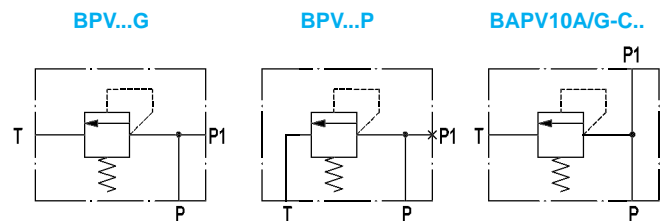


9.2a

9.2.2 DESCRIPTION

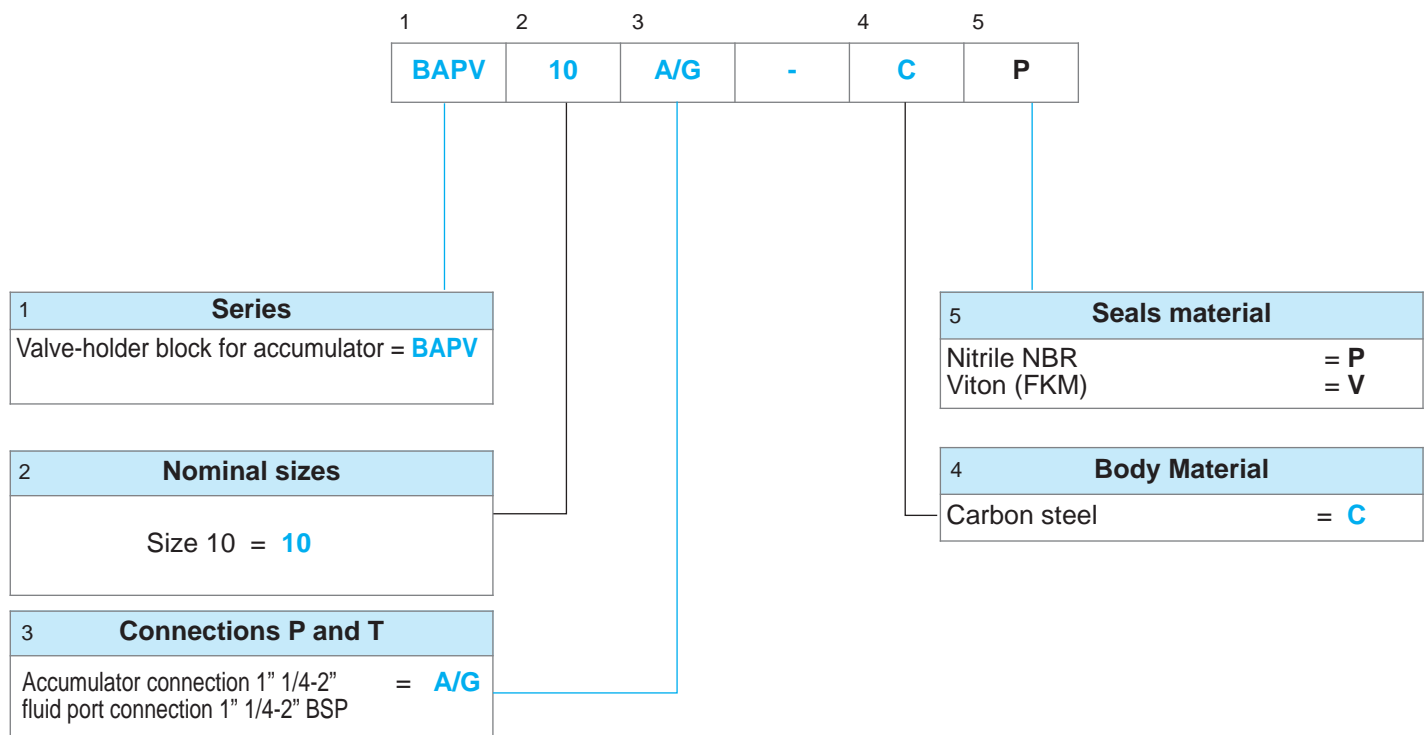
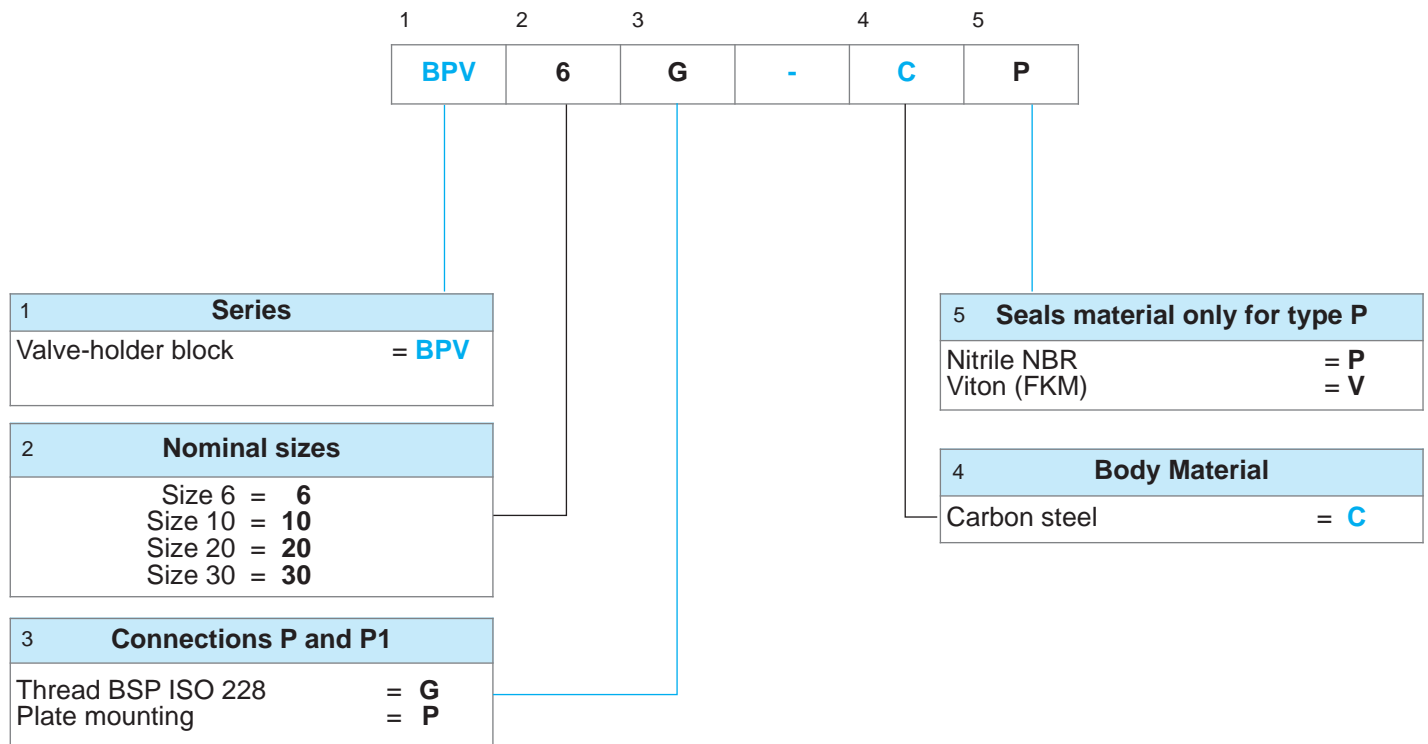
These blocks are used for installation of safety valves type DBDS (see Section 9.1) which must be ordered separately. The BPV type is built in sizes 6, 10, 20 and in the "G" versions with the threaded connections BSP ISO 228 or in the "P" version for mounting on plate. BAPV type instead can be mounted through a double thread nipple directly on the fluid valve of the bladder accumulators with a connection of 1"1/4 (type AS5 and ASA1) or 2" BSP (type AS10÷55, ASA2.5÷15) or with appropriate adaptors (see Section 9.4) directly on the back side of a fluid piston accumulator. This version is built only to accommodate the safety valves DBDS10.

9.2.2 HYDRAULIC SYMBOL

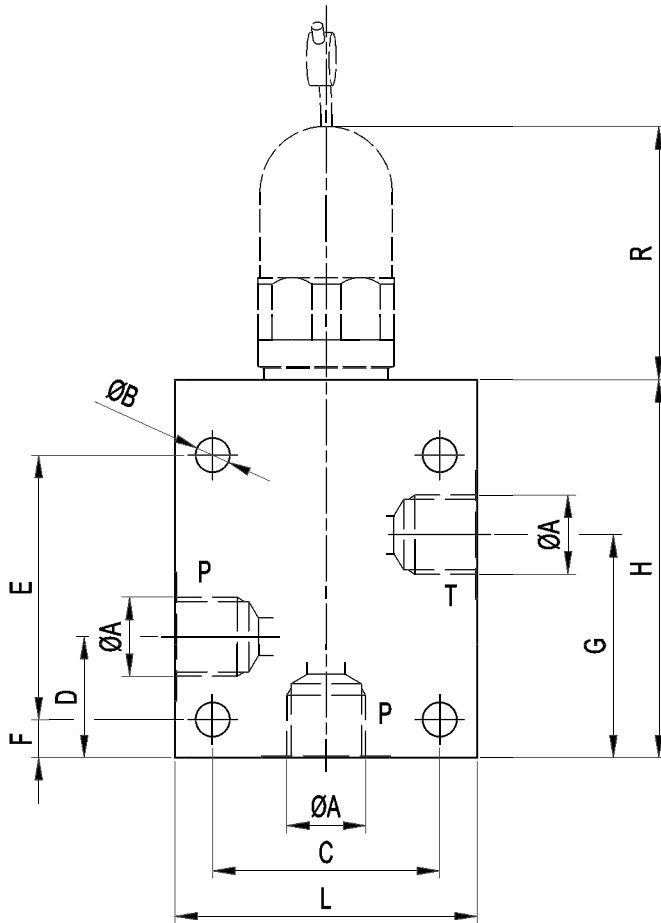


9.2b

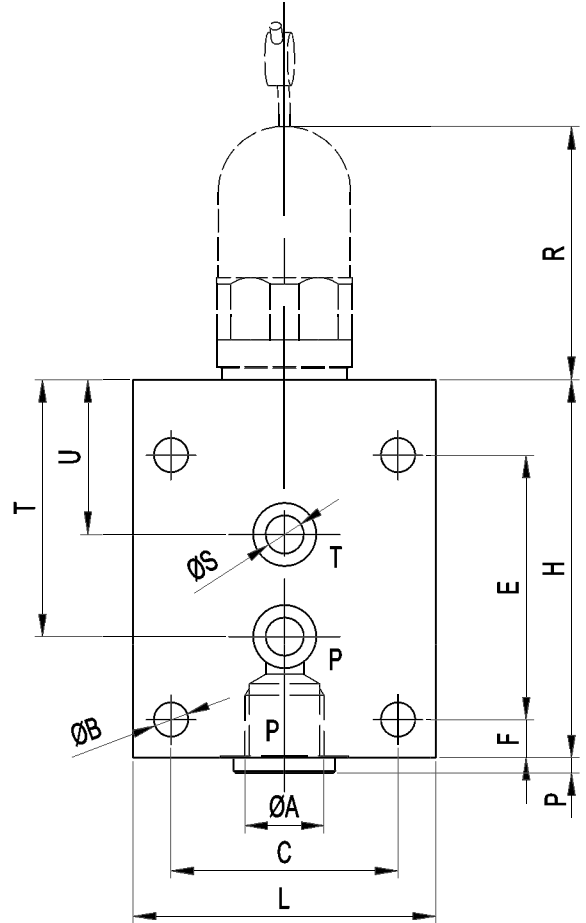
9.2.3 ORDER CODE



9.2.4.1 DIMENSIONS BPV "G" & "P" TYPE



BLOCK "G" TYPE



BLOCK "P" TYPE

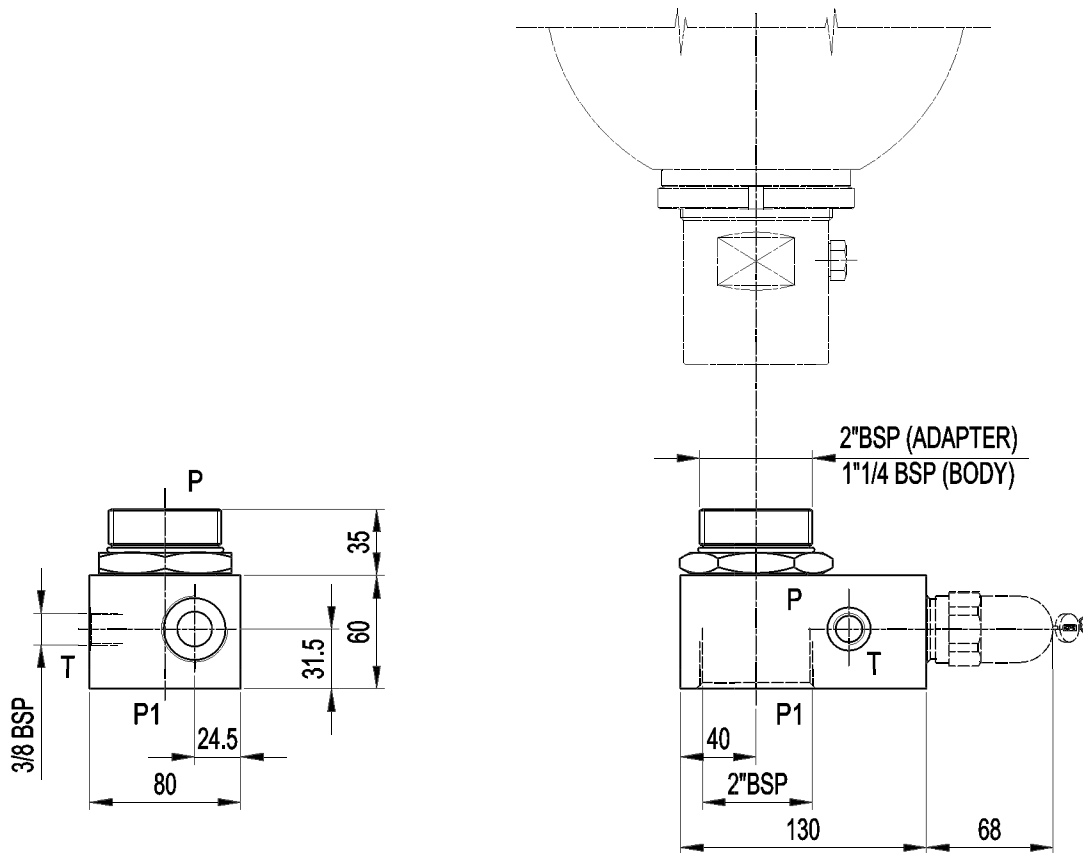
9.2c

Block order code	Valve order code	Ø A BSP	Ø B mm	C mm	D mm	E mm	F mm	G mm	H mm	I mm	L mm	M mm	P mm	Ø Q mm	R mm	S mm	T mm	U mm	OR metric	Weight Kg
BPV 6.. - C*	DBD... 6 K 1....	1/4"	6.6	45	25	55	10	45	80	40	60	25	4	M6	72	6	55	35	0010M7x1.5-*	1.5
BPV 10.. - C*	DBD... 10 K 1....	1/2"	9	60	32	70	10	59	100	60	80	40	4	M8	68	10	68	41	0010M12.3x2.4-*	3.7
BPV 20.. - C*	DBD... 20 K 1....	1"	9	70	50	100	15	81	135	70	100	50	5.5	M8	65	20	85	54	0010M22x3-*	6.4
BPV 30.. - C*	DBD... 30 K 1....	1" 1/2"	11	100	70	130	25	120	180	90	130	60	5.5	M10	83	30	110	55	0010M22x3-*	13.9

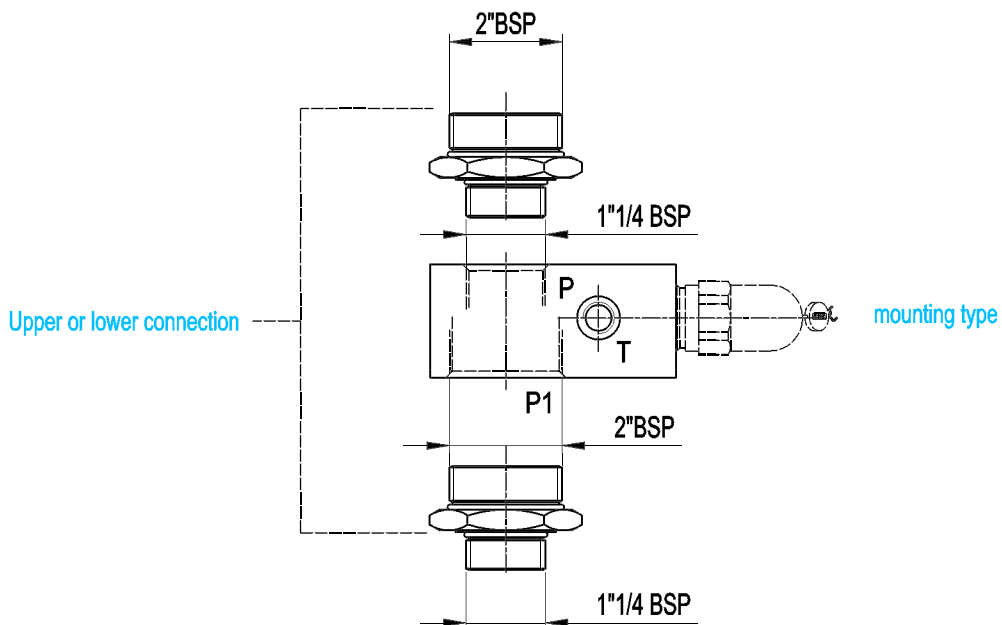
For "DBDS K" valve seat see chapter 9.1.7.1 table 9.1e

9.2d

BAPV10 TYPE



9.2e



9.2f

Block order code BAPV 10 A/G - C *

* gasket material

Reproduction is forbidden.

In the spirit of continuous improvement, our products may be changed.

9.3.1 TECHNICAL DATA

MAX OPERATING PRESSURE (PS): 420 bar

PRESSURE TEST (PT): 1.43 x PS

NOMINAL PASSAGE DIAMETER: 10mm, 20mm, 25mm, 32mm

WORKING TEMPERATURE: -40 ÷ +150

FLUID VISCOSITY RANGE: 10 ÷ 400 cSt

RECOMMENDED VISCOSITY: 36 cSt

FLUID CONTAMINATION DEGREE: class 21/19/16 according to ISO 4406/99

SHUT-OFF VALVE: ball type

SAFETY VALVE: with DBDS 10 cartridge

DISCHARGE VALVE: manual and electric

MOUNTING POSITION: every position

BODY MATERIAL: - phosphated or galvanized carbon steel
in compliance with Directive 2002/95/EC (RoHS) to resist to corrosion.
- nickel coating 25 - 40 µ
- stainless steel AISI 430 (only for BS25)

VALVES MATERIAL: - phosphated or galvanized carbon steel in compliance with Directive 2002/95/EC (RoHS) to resist to corrosion
- stainless steel

SEALS MATERIAL:

- P = Nitrile rubber (NBR)
- F = Low temp. nitrile rubber
- K = Hydrogenated nitrile (HNBR)
- E = Ethylene-propylene (EPDM)
- V = Fluorocarbon (FPM)

See Table 9.3B and/or section 1.5

ACCUMULATOR SIDE CONNECTION:

- 3/4" BSP with O-Ring for chamfer
- 1"1/4 BSP with O-Ring for chamfer
- 2" BSP with O-Ring for chamfer

FLUID PORT CONNECTION: see Chapter 9.3.8

FLOW RATE: see Chapter 9.3.10

POWER SUPPLY: 24 VDC, 105 VDC, 110 VDC, 220 VDC, P=26W, 100%ED, IP65 in compliance with DIN 40050, connector in compliance with DIN 43650 type A 2 poles + earthing with AC voltage; the internal connector has a bridge rectifier

WEIGHT: see Chapter 9.3.8



9.3a

9.3.2 HYDRAULIC SYMBOL

See section 9.3.8

9.3.3 DESCRIPTION

The EPE range of safety blocks BS is available in sizes NG10, NG20, NG25 and NG32. The safety blocks BS combine all the features to protect, isolate and discharge a hydraulic accumulator. The shut-off valve rotates of 90 degrees to instantly isolate the accumulator from the hydraulic system in emergency conditions or for maintenance. Once isolated, the accumulator can be discharged into a tank through a discharging valve with manual or electric controls. In version BS10 and BS20 when switching over the ball valve, the pump flow rate is stopped and simultaneously the accumulator discharged to the tank. During switching all three ports (P, A and T) are momentarily interconnected (negative switching overlap). Ball valves are not designed to be used as flow control valves; therefore they should always be either fully open or fully closed, to avoid damaging the sealing cups. The system security is ensured by a pressure PED an anti-tempering pressure valve certified CE/PED. The safety blocks BS allow easy and secure connection of an accumulator to a hydraulic system. Suitable for use with all types of bladder, piston and diaphragm accumulators, the compact and multifunction design allows saving space and reducing the wiring. By reducing the times required by the procedures of installation and maintenance, the security blocks BS help maximizing the productivity and profitability, minimizing the downtime of the system. For easy installation, we offer a full range of adapters, suitable for all standard fittings of any size and type. For diagnostic purposes and for continuous monitoring of pressure, all the security blocks BS are provided with a manometer connection of 1/4" BSP. The European Directive on pressure equipment 97/23/EC states that all accumulators must be provided with a safety device that intercepts, limit and discharge the pressure as well as allows carrying out the measurements. BS range satisfies all these requirements with a single and compact device. The safety block should always be mounted as close as possible to the accumulator.

9.3.4 PRESSURE RELIEF VALVE

The function of the pressure relief valve is to protect the accumulator during its operation. If the pressure exceeds the valve setting, this opens and discharges the fluid into the tank and allows the pressure in the system returning to a safe level. Thanks to its cartridge design, the pressure relief valve can be recalibrated to another pressure setting. This change requires a new approval according to PED 97/23 EC. The vessels discharge pressure expressed in bar, is stamped on the nameplate. The pressure relief valve is controlled and carefully sealed after approval in accordance with the rules of pressurized vessels. On their body there are stamped the CE mark, the certification ID and the serial number. All valves are supplied with a certificate attesting the calibration pressure. The documents provided with the pressure relief valve must be kept as they may be necessary in the event of repetition of the tests.

Manual and electric discharge valve

The discharge valve allows the discharge of the accumulator fluid in the

tank. All models of the safety block BS have a manually operated valve. In addition to the manual valve on request, could be installed a discharging electrically-controlled valve.

9.3.5 SAFETY BLOCK ADVANTAGES

- dirt tolerant
- light weight
- compact
- simple construction
- quick response
- works well on water, low lubricity fluids
- quick, easy installation
- low cost

9.3.6 SEALS-TEMPERATURE-LIQUID COMPATIBILITY

When selecting the additional seal variant, pay attention to the following non-binding notes with regard to hydraulic fluid, seals material and the permissive temperature range. (see Section 1.5)

Code letter	Polymer	ISO	Temperature range (°C)	Some of the liquids compatible with the polymer
P	Standard nitrile (Perburan)	NBR	-20 ÷ +80	Aliphatic hydrocarbons (propane, butane, gasoline, oils, mineral greases, diesel fuel, fuel oil, kerosene), mineral greases and oils, HFA - HFB - HFC fluids, many dilute acids, alkalis, saline solutions, water, water glycol
F	Low temperature nitrile	NBR	-40 ÷ +70	The same as with standard nitrile + a number of different types of Freon. (This contains less acrylonitrile than the standard and is therefore more suitable for low temperatures, but its chemical resistance is slightly lower).
K	Hydrogenated nitrile	HNBR	-30 ÷ +130	The same as with standard nitrile but with excellent performance at high and low temperatures.
E	Ethylene-Propylene	EPDM	30 ÷ +100	Hot water up to 100°C, glycol-based brake fluids, many organic and inorganic acids, detergents, solutions of sodium and potassium, phosphate ester-based hydraulic fluids, (HFD-R), silicone oils and greases, many polar solvents (alcohol, ketones, esters), Skydrol 500 and 7000, resistance to ozone, aging and weathering.
V	Fluorocarbon	FPM	-10 ÷ +150	Mineral oils and greases, non-flammable fluids of HFD group, silicone oils and greases, animal and vegetable oils and greases, aliphatic hydrocarbons (gasoline, butane, propane, natural gas), aromatics hydrocarbons (benzene, toluene), chlorinated hydrocarbons (Tetrachloroethylene, carbon tetrachloride), fuel (regular, super and containing methanol), excellent resistance to ozone, weathering and aging.

9.3b

For other hydraulic fluid and/or temperatures, please consult us.

9.3.7 ORDER CODE

1	2	3	4	5	6	7	8	9	10	11	12	
BS	10	M	P	360	A	5	G	4	-	C	P	K

1	Series
Safety block	= BS

2	Internal nominal diameter
10mm	= 10
20mm	= 20
25mm	= 25
32mm	= 32

3	Discharge
Only manual	= M
Electric and manual	= E
Manual plus drilling for solenoid valve	= F

4	Relief valve
Without valve, with plastic plug	= A
Valve type DBDS...(CE certified)	= P
Without valve (with plug B 2375)	= T
Valve type VS224TX	= G
Valve type DBDS (Gost certified)	= U

5	Valve setting (bar)
Valves type DBDS or VS224 calibrated and certificate	= 5 ÷ 400

6	Accumulator side connection
BSP ISO 228 with chamfer for OR (std)	= A
For BS25 and BS32: Holes for flange SAE 3000 Psi	= L
Without adapter	= W

7	Dimension of the accumulator side connection
For connection A: 3/4"BSP	= 5
1"1/4BSP	= 7
2"BSP	= 9
For connection L: 2"	= 9
Without adapter	= 0

8	Type of installation side connection
For BS25 and BS32: holes for flange CETOP -400, metric threads with flange FC	= C
For BS32: holes for flange SAE 3000 Psi, metric threads	= L
For BS25 e BS32: holes for flange SAE 6000 Psi, metric threads	= H
Thread BSP ISO 228	= G

12	Other variants
For type BS...E	
Sol. valve power supply 24VDC normally closed	= 24D-C
Sol. valve power supply 110VDC normally closed	= 110D-C
Sol. valve power supply 220VDC normally closed	= 220D-C
Sol. valve power supply 24VAC normally closed	= 24A-C
Sol. valve power supply 110VAC normally closed	= 110A-C
Sol. valve power supply 220VAC normally closed	= 220A-C
Sol. valve power supply 24VDC normally open	= 24D-O
Sol. valve power supply 110VDC normally open	= 110D-O
Sol. valve power supply 220VDC normally open	= 220D-O
Sol. valve power supply 24VAC normally open	= 24A-O
Sol. valve power supply 110VAC normally open	= 110A-O
Sol. valve power supply 220VAC normally open	= 220A-O
Handle of the padlocked ball valve = K	
Micro-switch on the ball handle = S	
Two connections for manometer = M2	
Discharge connection in installation side only for BS 25/32 = 1	
Special variants on request	

11	Seal material
Nitrile rubber (NBR)	= P
Nitrile for low temp.	= F
Hydrogenated nitrile (HNBR)	= K
Ethylene-propylene (EPDM)	= E
Fluorocarbon (FPM)	= V

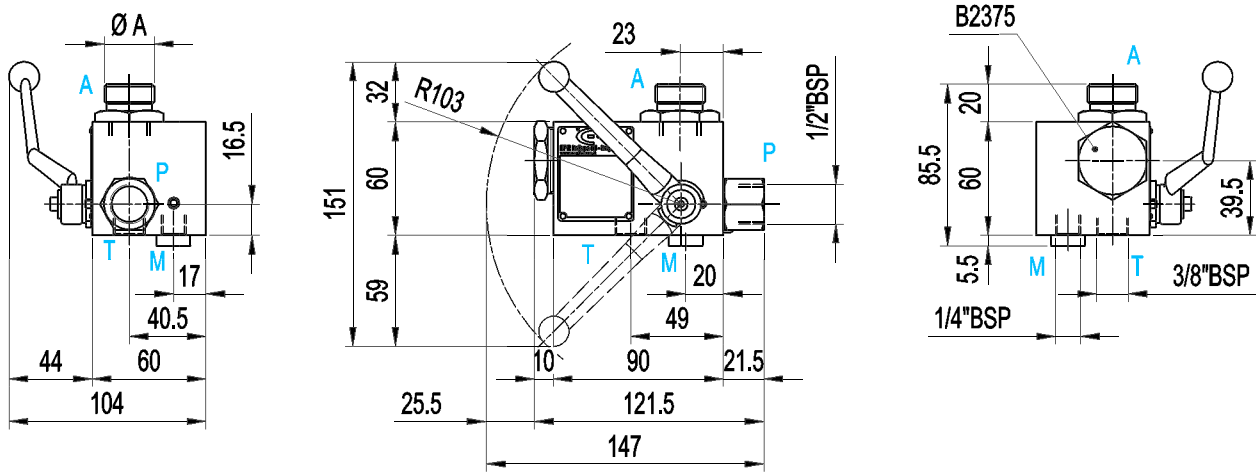
10	Block material
Carbon steel	= C
Nickel coated steel 25 μ.	= N
Nickel coated carbon steel 40 μ	= M
Stainless steel AISI 430 L (only for BS25)	= X
(only for DBDS in stainless steel)	= CX

9	Dimension of the installation side connection
For BS10 1/2"BSP	= 4
For BS20 3/4"BSP	= 5
For BS25 G 1"	= 6
H 1"1/4	= 7
C 1"1/4	= 7
For BS32 G 1"1/2	= 8
L 1"1/2	= 8
L 2"	= 9
H 1"1/4	= 7
H 1"1/2	= 8
C 1"1/4	= 7
C 1"1/2	= 8

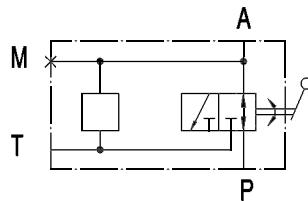
Special variants on request

9.3.8 DIMENSIONS

BS10MT..A.G.. - ...

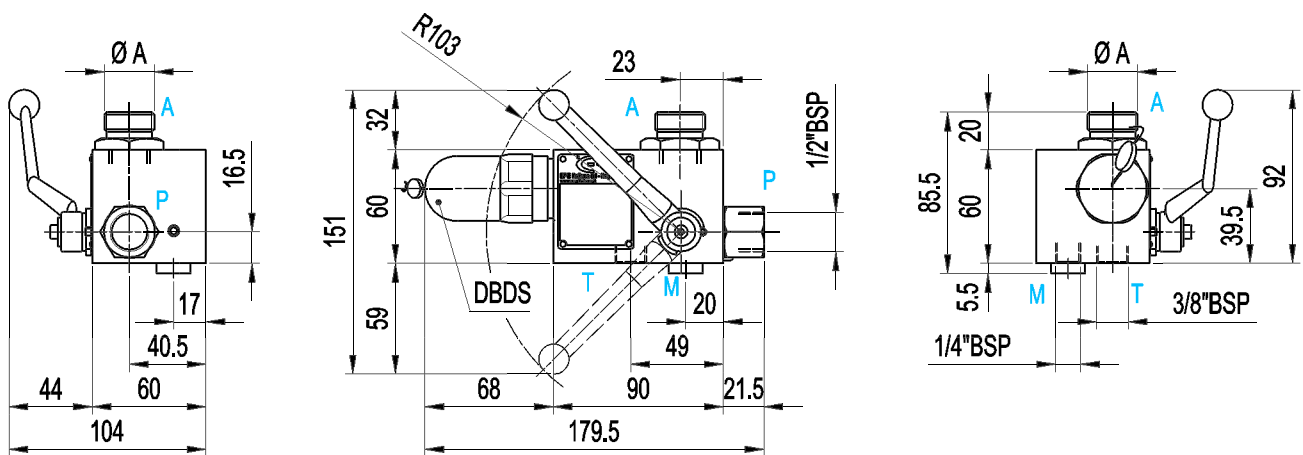


Order code	ØA	Weight
BS10MT...A5...	3/4" BSP	2.7
BS10MT...A7...	1" 1/4 BSP	2.9
BS10MT...A9...	2" BSP	3

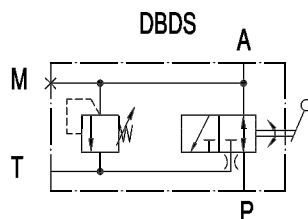


9.3ca

BS10MP..A.G.. - ...

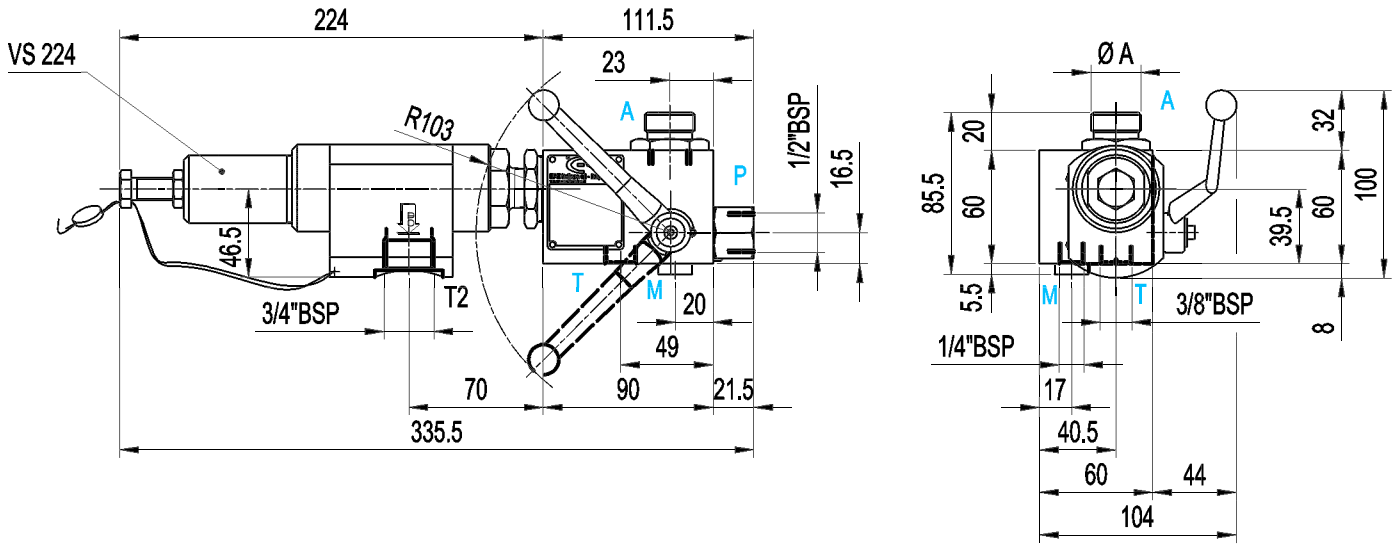


Order code	ØA	Weight
BS10MP...A5...	3/4" BSP	3.2
BS10MP...A7...	1" 1/4 BSP	3.4
BS10MP...A9...	2" BSP	3.5

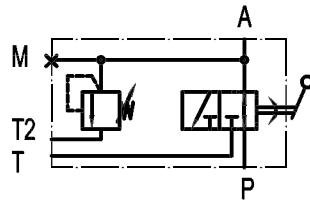


9.3cb

BS10MG..A.G.. - ...

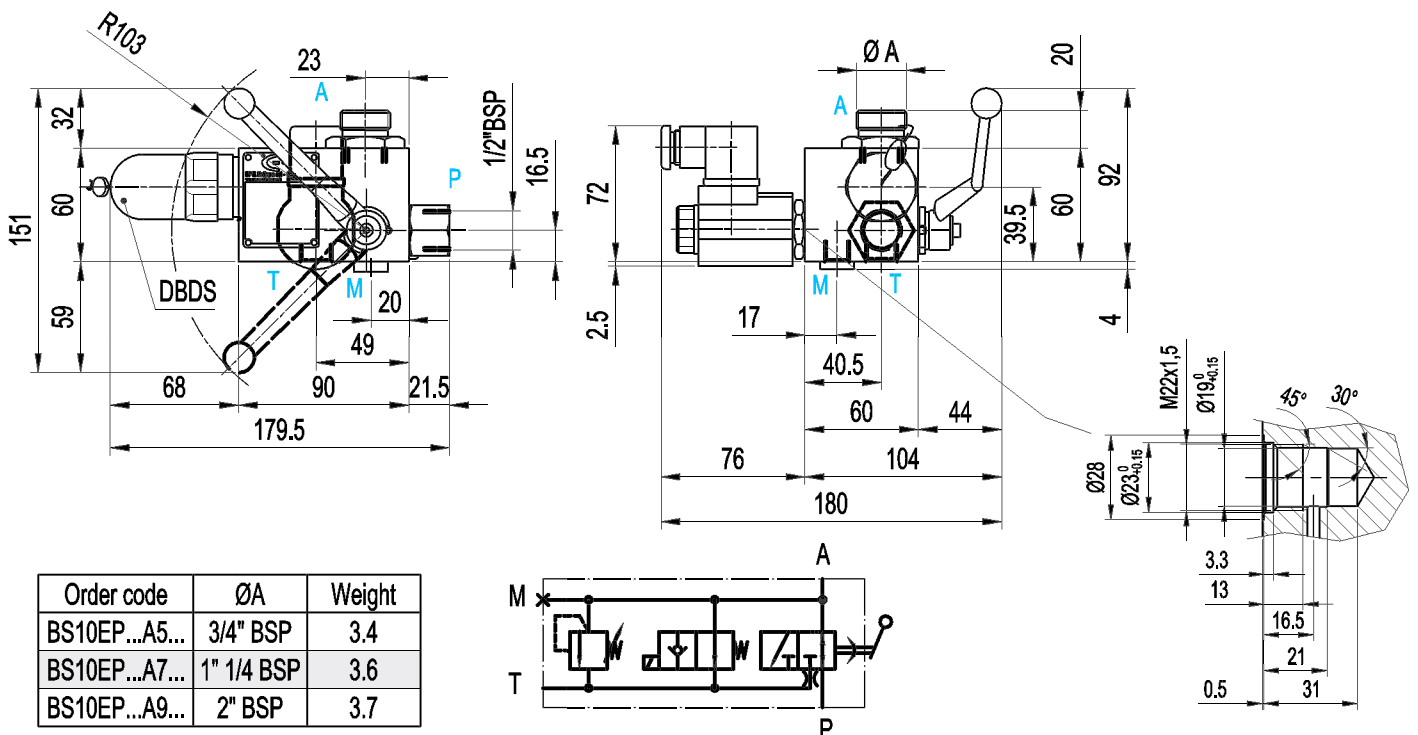


Order code	ØA	Weight
BS10MG...A5...	3/4" BSP	4.9
BS10MG...A7...	1" 1/4 BSP	5.1
BS10MG...A9...	2" BSP	5.2

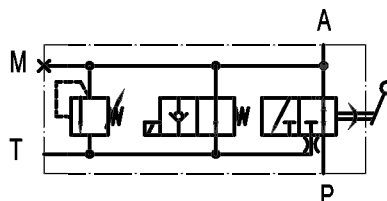


9.3cc

BS10EP..A.G.. - ...

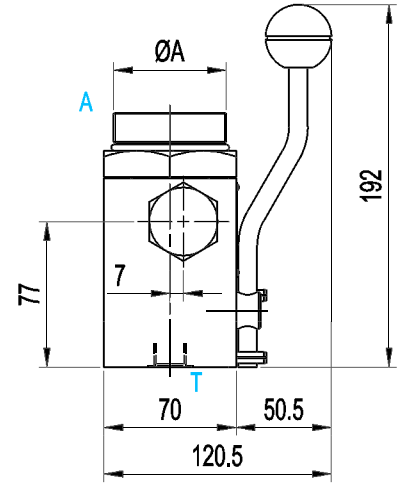
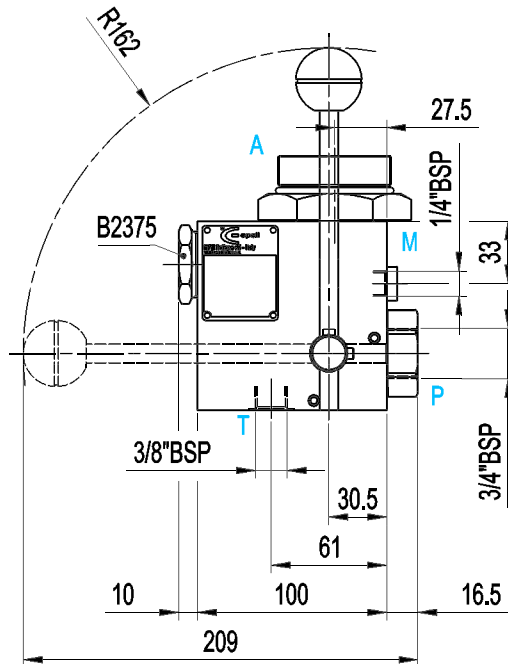
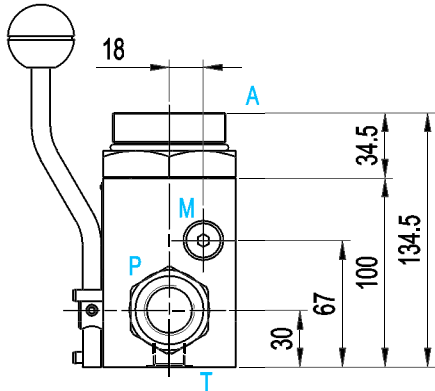


Order code	ØA	Weight
BS10EP...A5...	3/4" BSP	3.4
BS10EP...A7...	1" 1/4 BSP	3.6
BS10EP...A9...	2" BSP	3.7

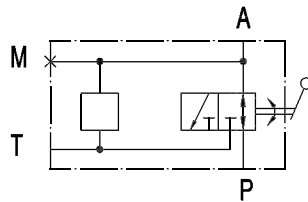


9.3cd

BS20MT..A.G.. - ...

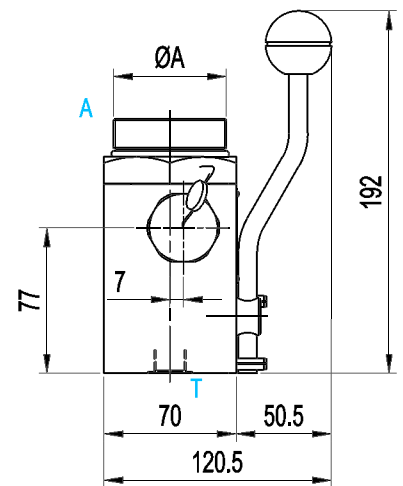
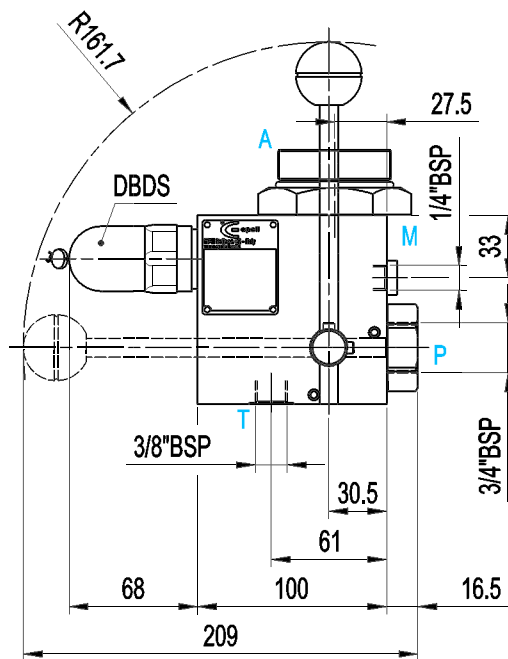
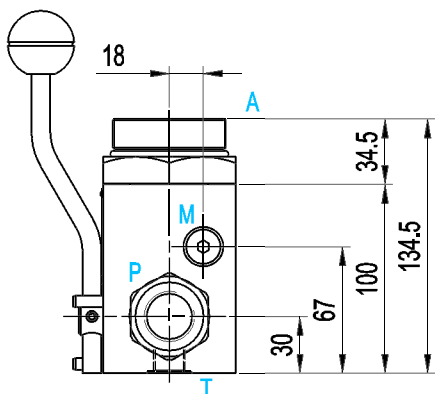


Order code	ØA	Weight
BS20MT...A7...	1" 1/4 BSP	5.6
BS20MT...A9...	2" BSP	6.1

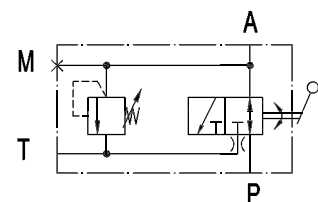


9.3ce

BS20MP..A.G.. - ...

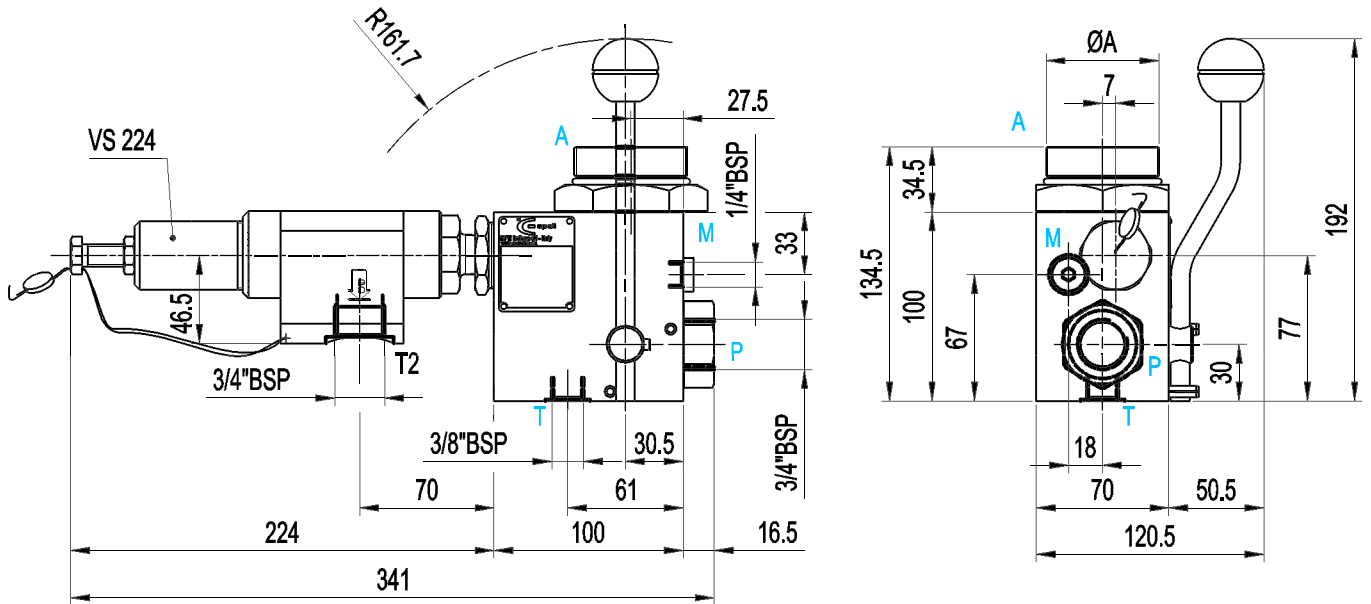


Order code	ØA	Weight
BS20MP...A7...	1" 1/4 BSP	6.1
BS20MP...A9...	2" BSP	6.7

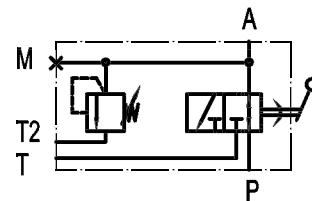


9.3cf

BS20MG..A..G.. - ...

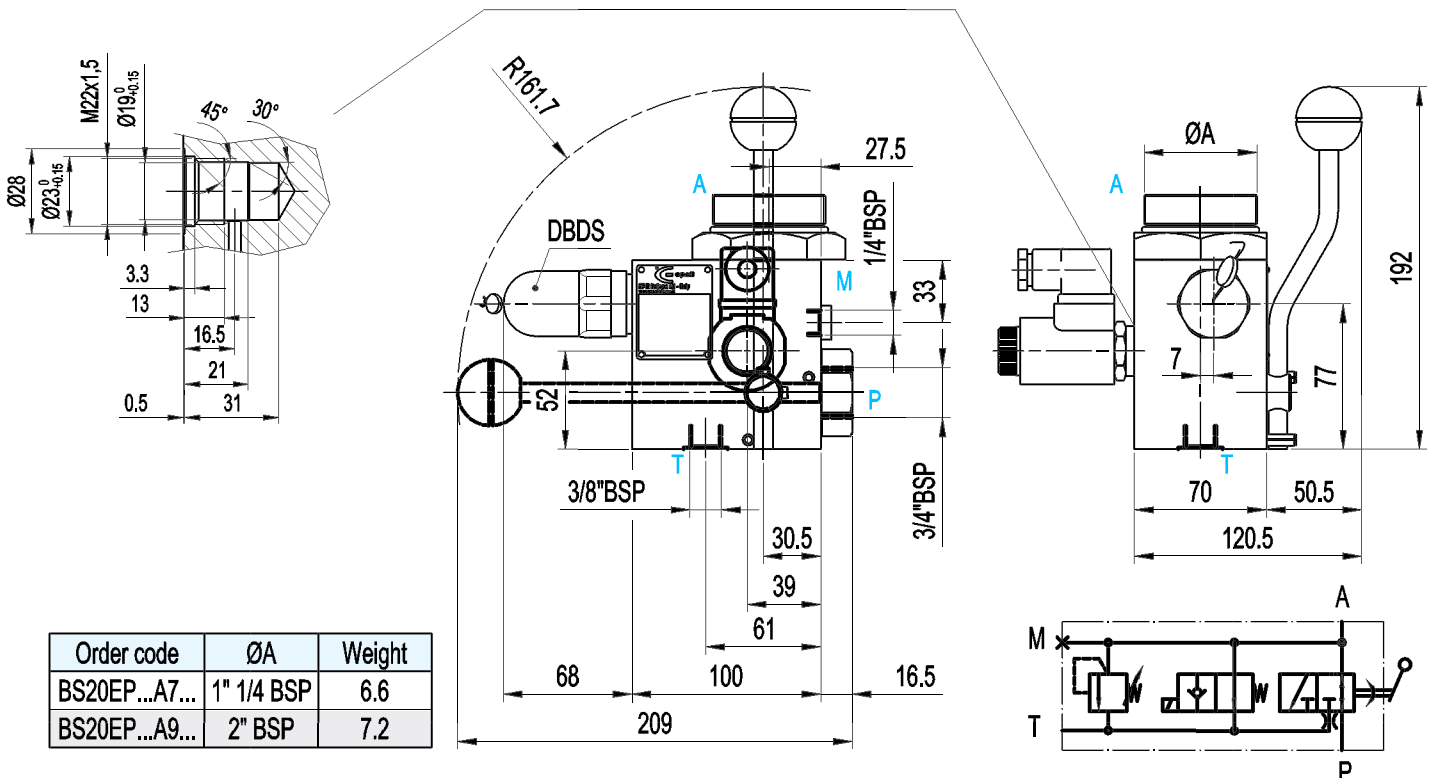


Order code	ØA	Weight
BS20MG...A7...	1" 1/4 BSP	7.8
BS20MG...A9...	2" BSP	8.3

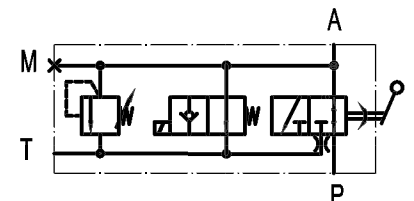


9.3cg

BS20EP..A..G.. - ...

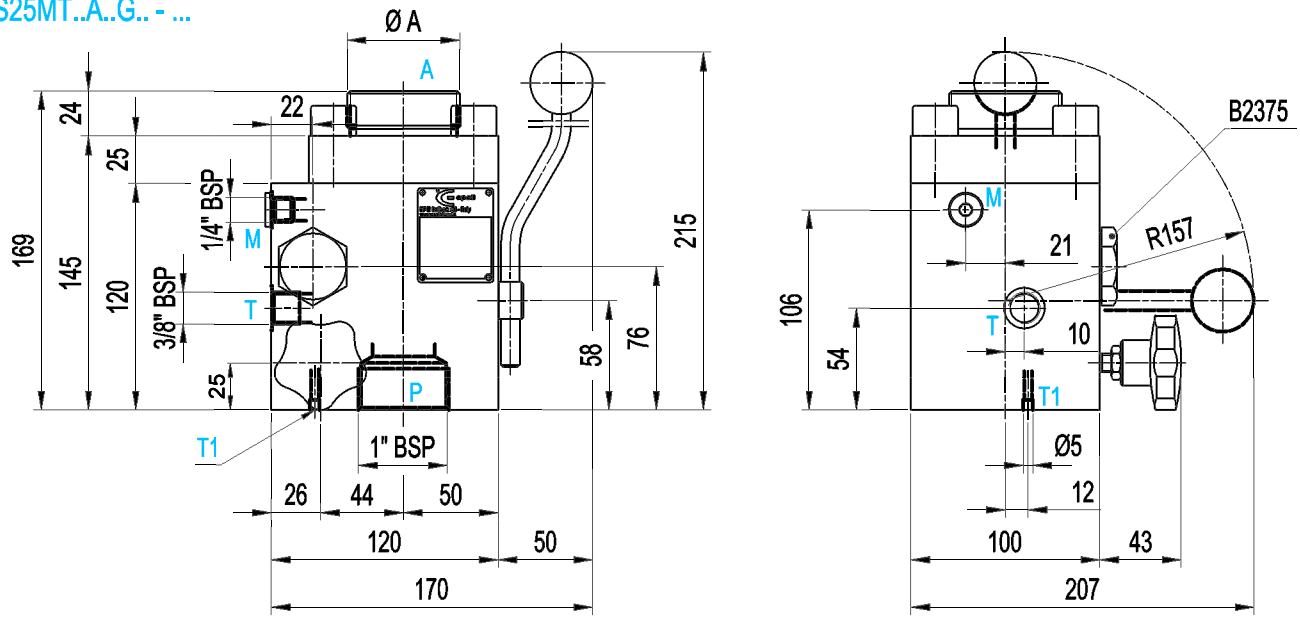


Order code	ØA	Weight
BS20EP...A7...	1" 1/4 BSP	6.6
BS20EP...A9...	2" BSP	7.2

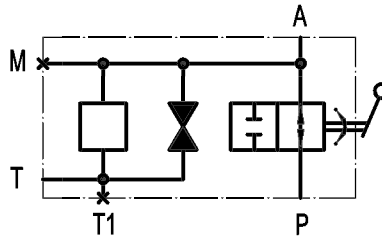


9.3ch

BS25MT..A..G.. - ...

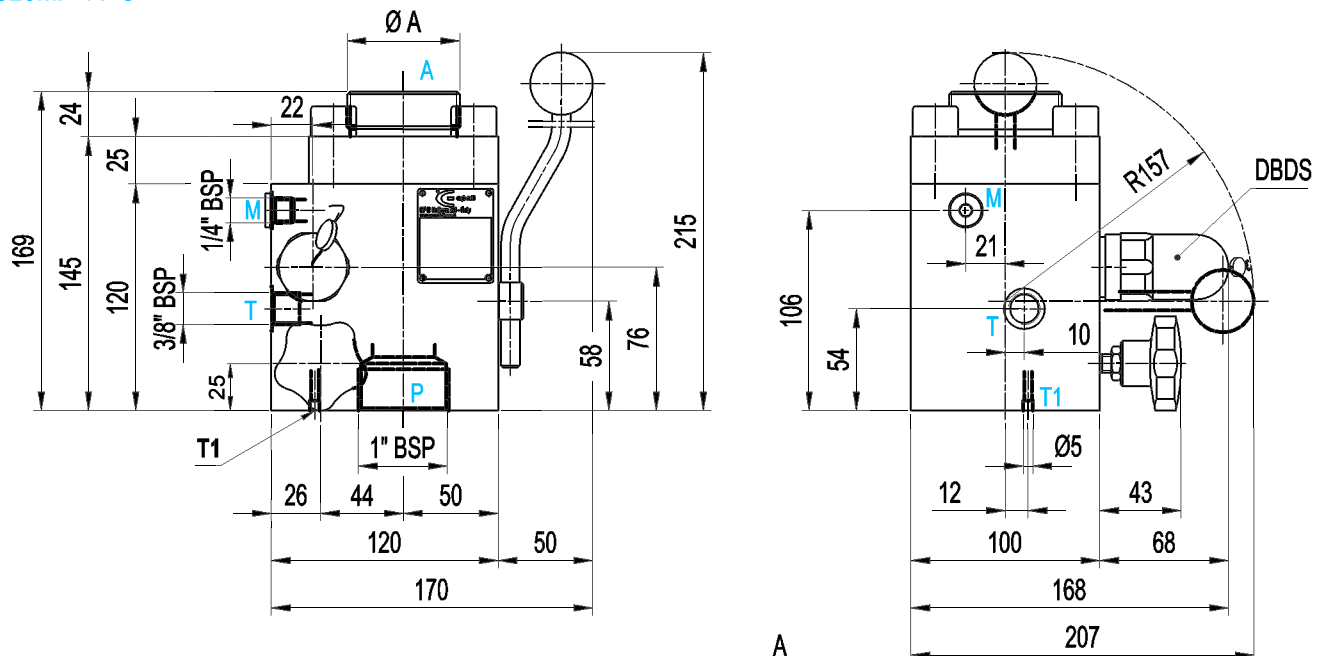


Order code	ØA	Weight
BS25MT...A7...	1" 1/4 BSP	12.4
BS25MT...A9...	2" BSP	12.5

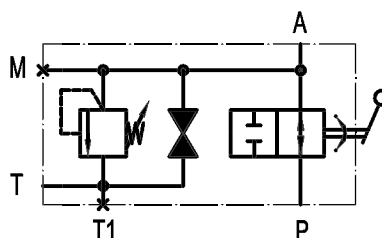


9.3ci

BS25MP..A..G.. - ...

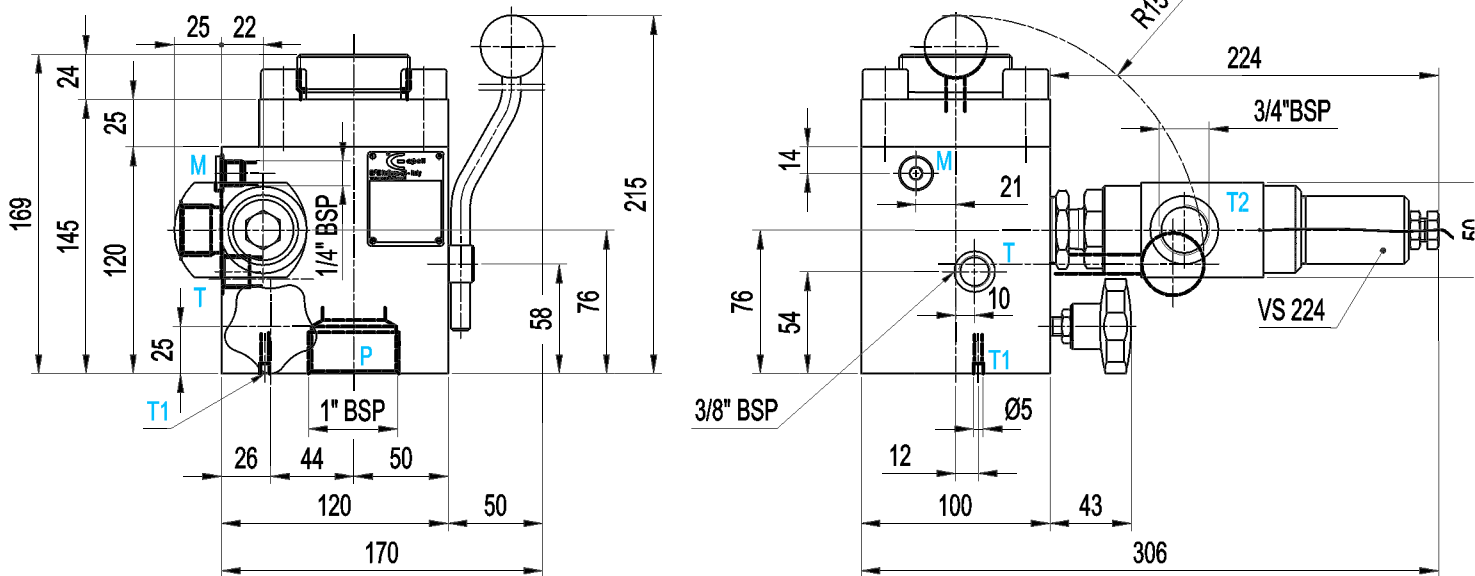


Order code	ØA	Weight
BS25MP...A7...	1" 1/4 BSP	12.7
BS25MP...A9...	2" BSP	12.9

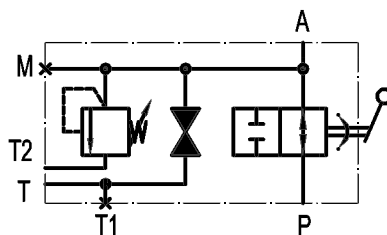


9.3cj

BS25EG.A.G. - ...

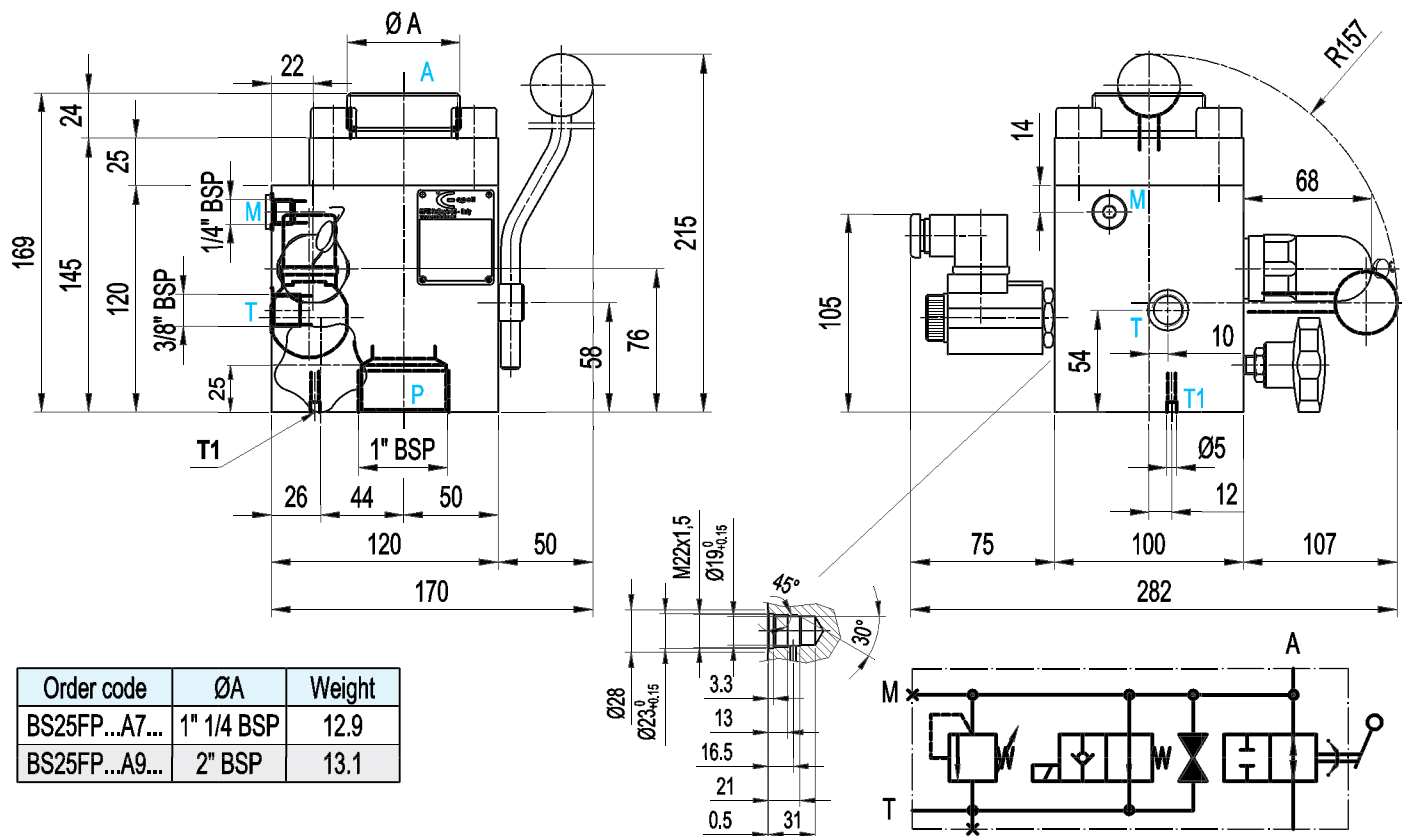


Order code	ØA	Weight
BS25EG...A7...	1" 1/4 BSP	14.5
BS25EG...A9...	2" BSP	14.6

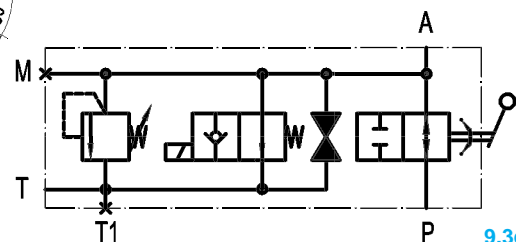


9.3ck

BS25FP.A.G. - ...

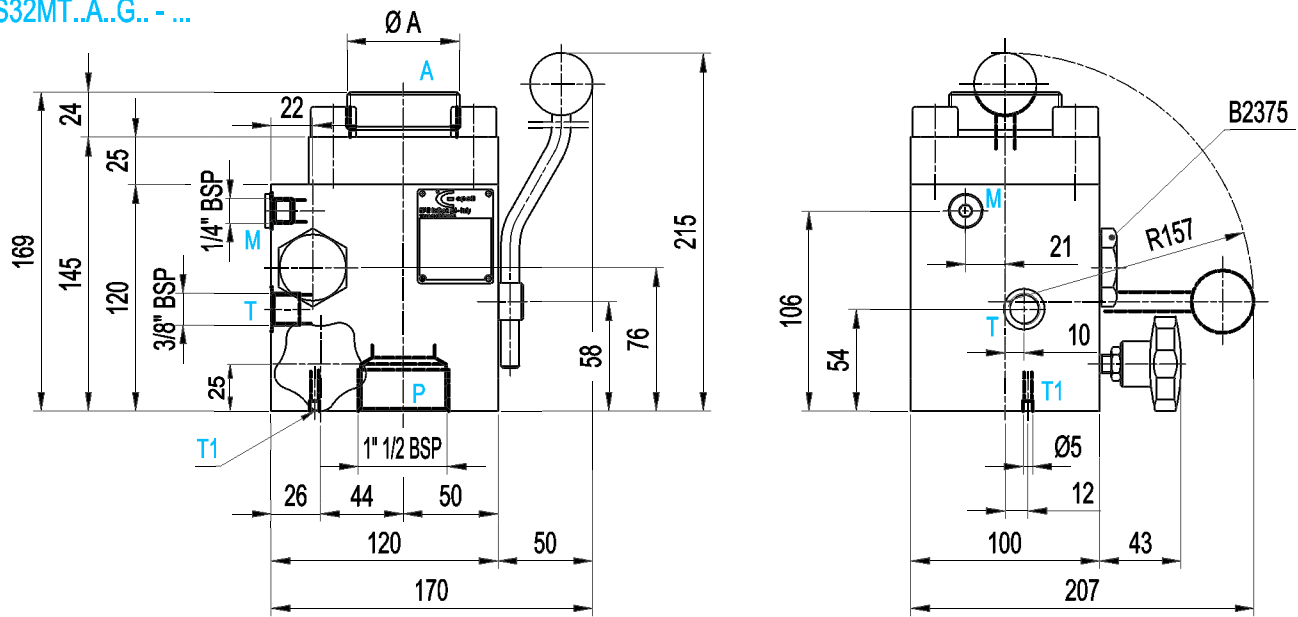


Order code	ØA	Weight
BS25FP...A7...	1" 1/4 BSP	12.9
BS25FP...A9...	2" BSP	13.1

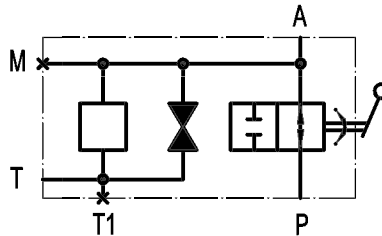


9.3cl

BS32MT..A..G.. - ...

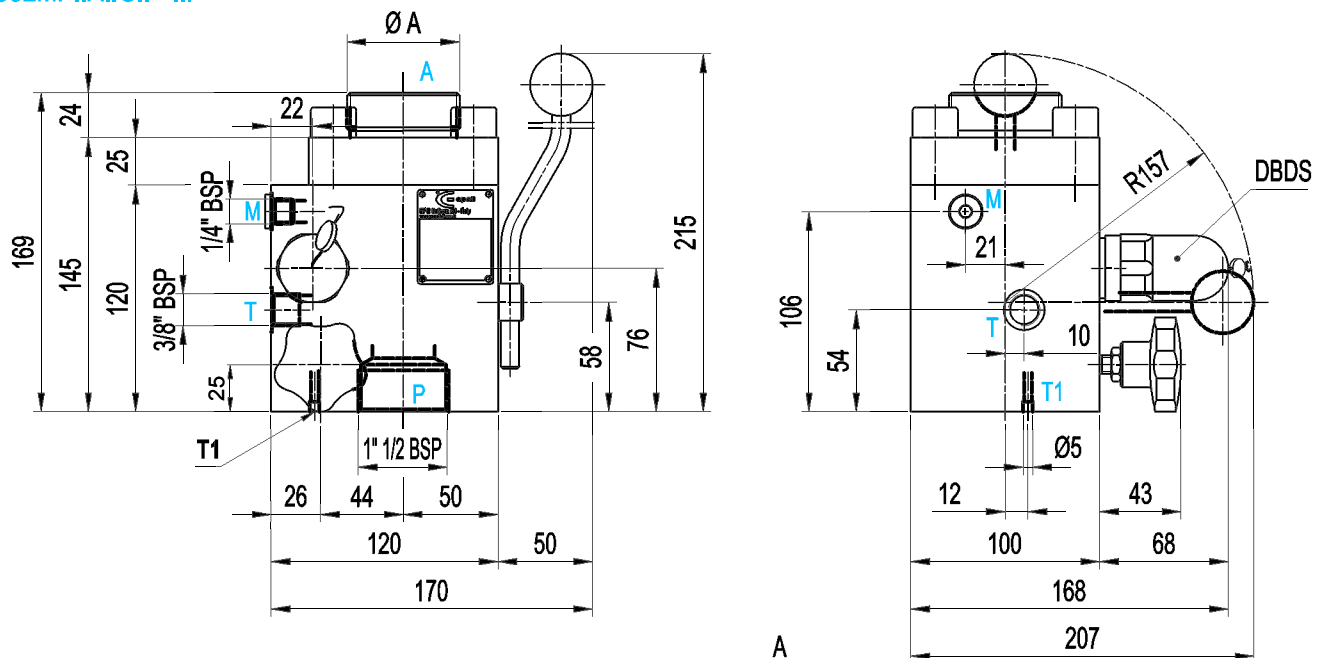


Order code	ØA	Weight
BS32MT...A7...	1" 1/4 BSP	12.4
BS32MT...A9...	2" BSP	12.5

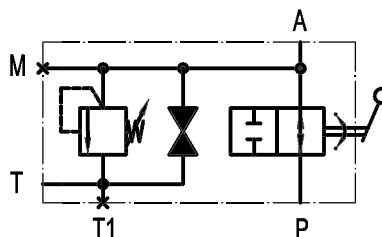


9.3cm

BS32MP..A..G.. - ...

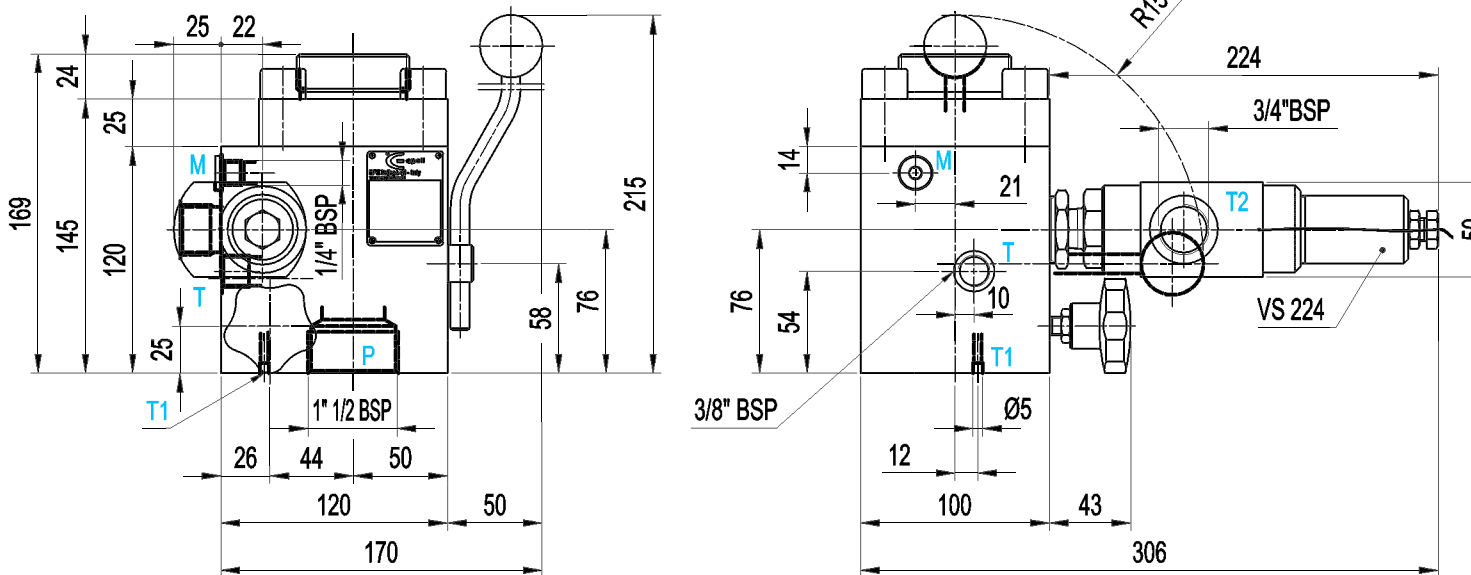


Order code	ØA	Weight
BS32MP...A7...	1" 1/4 BSP	12.7
BS32MP...A9...	2" BSP	12.9

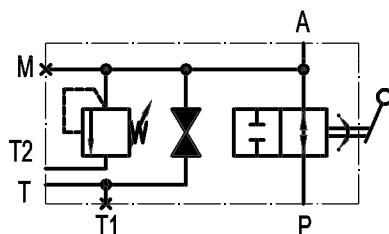


9.3cm

BS32MG..A.G.. - ...

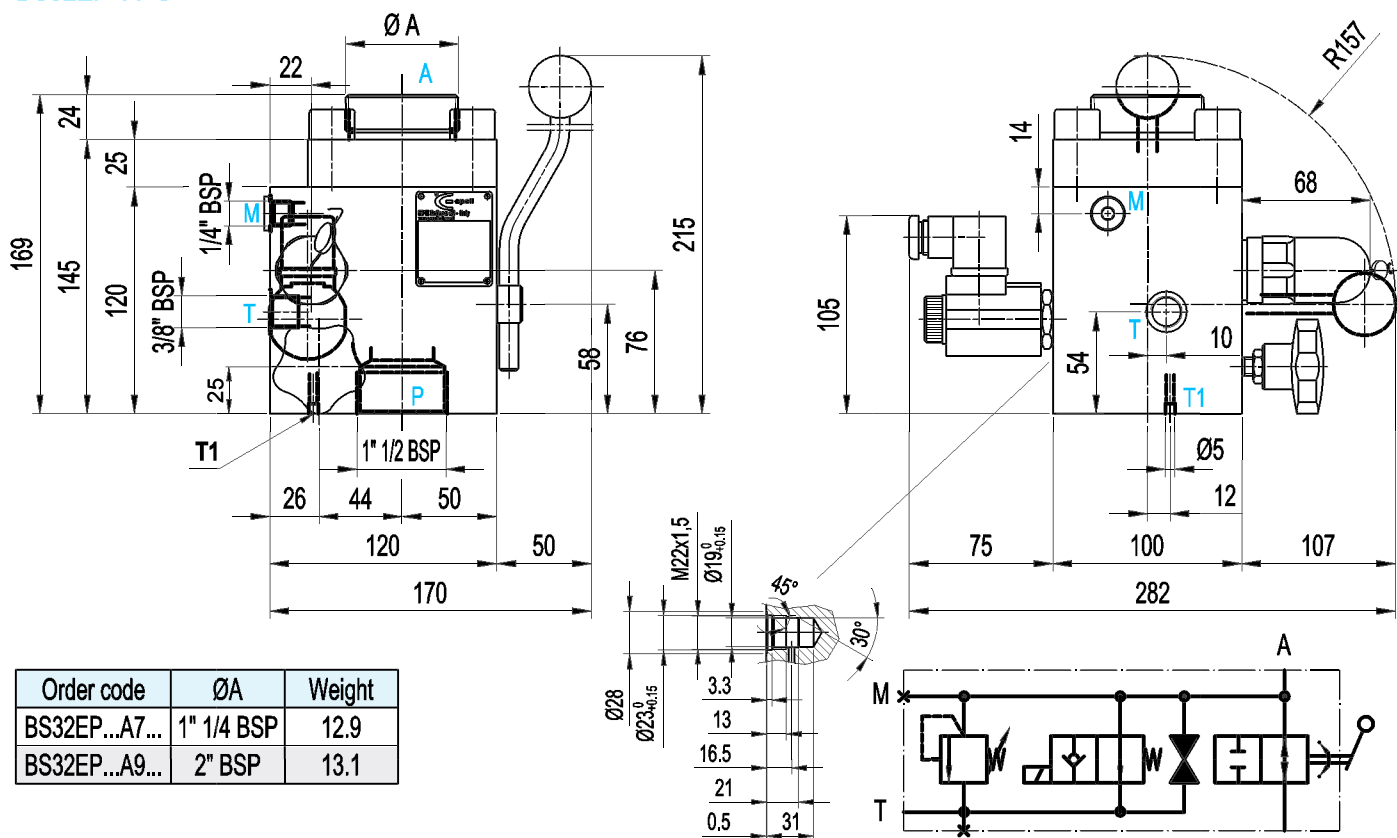


Order code	ØA	Weight
BS32MG...A7...	1" 1/4 BSP	14.5
BS32MG...A9...	2" BSP	14.6

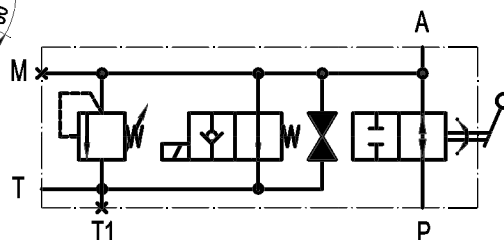
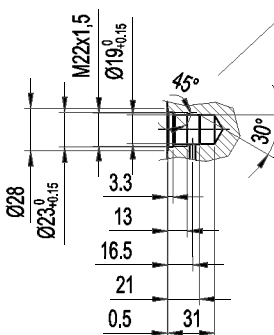


9.3co

BS32EP..A.G.. - ...

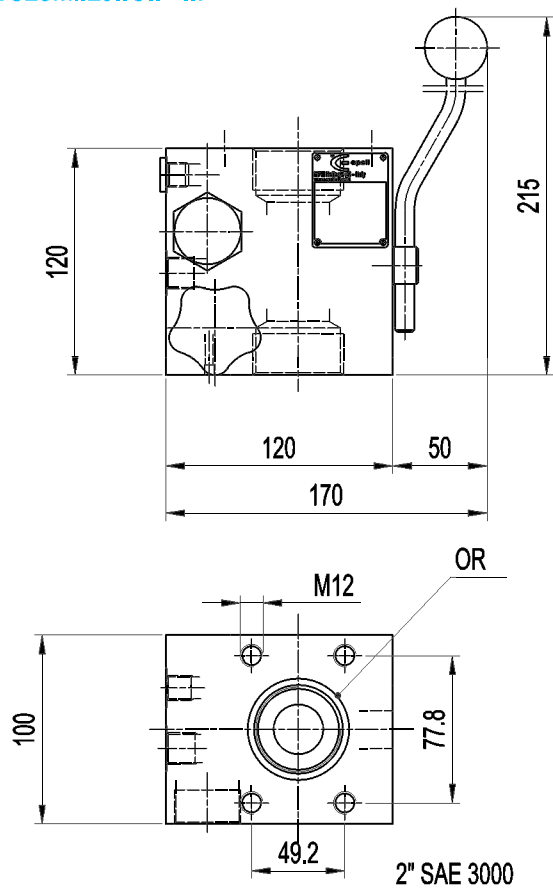


Order code	ØA	Weight
BS32EP...A7...	1" 1/4 BSP	12.9
BS32EP...A9...	2" BSP	13.1



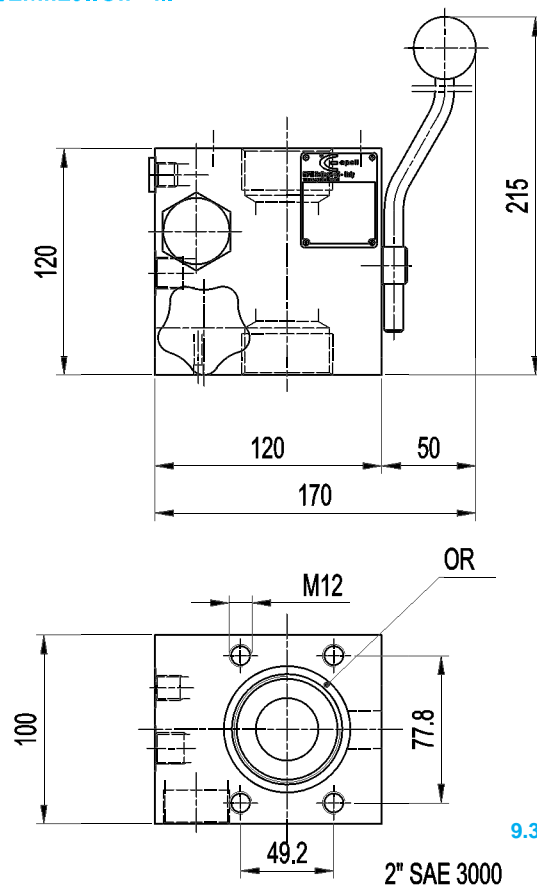
9.3cp

BS25M..L9..G.. - ...



9.3cq

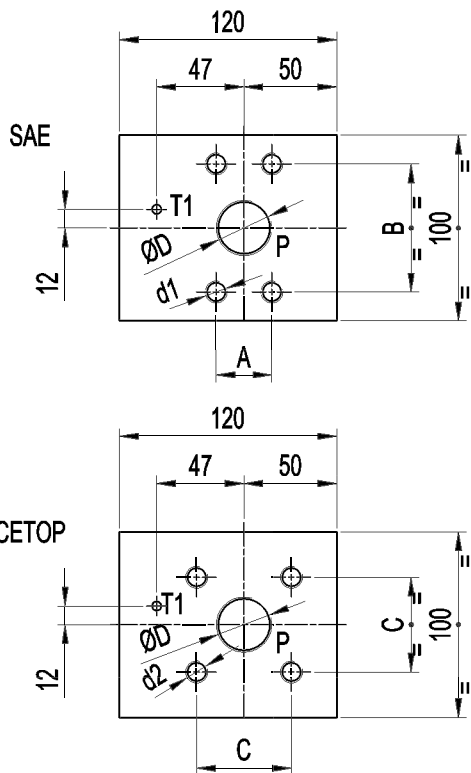
BS32M..L9..G.. - ...



9.3cr

Other dimensions see previous pages

Other dimensions see previous pages

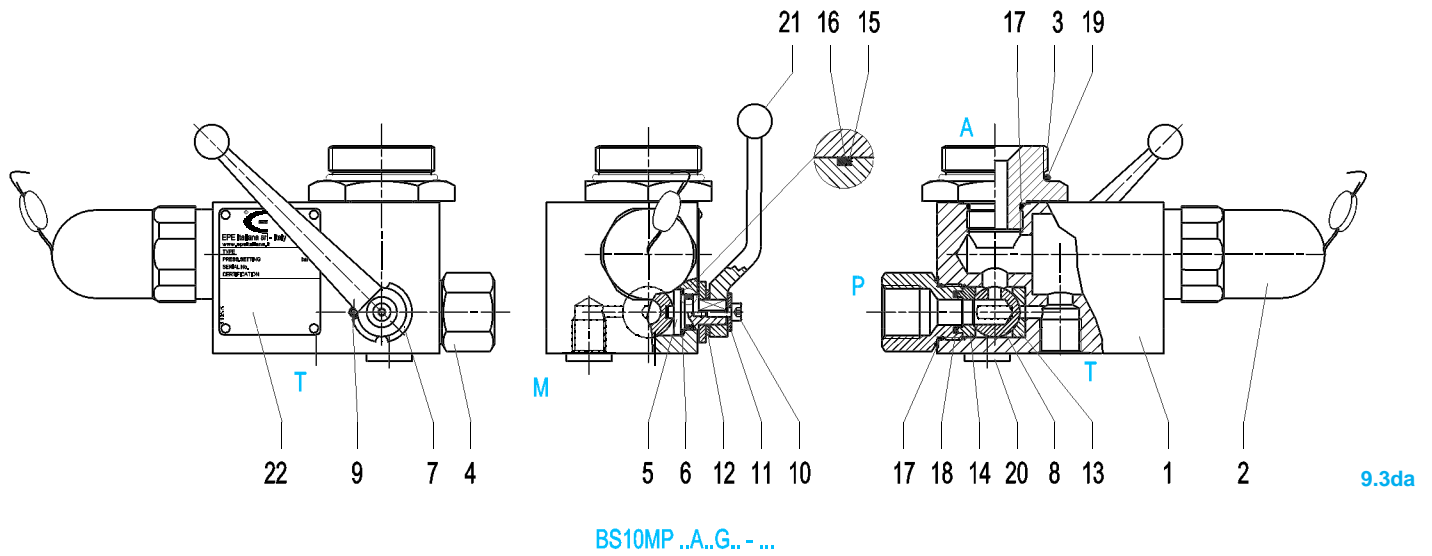


9.3cs

Type.	On request								
	For SAE Flanges					For CETOP Flanges			
		A	B	d1	Thread deep		C	d2	Thread deep
BS25	1" 1/4 SAE 6000	31,6	66,7	M14	24	CETOP 1" 1/4-400	51,6	M12	20
	1" 1/4 SAE 6000	31,6	66,7	M14	24	CETOP 1" 1/4-400	51,6	M12	20
BS32	1" 1/2 SAE 6000	36,7	79,4	M16	24				
	1" 1/2 SAE 3000	35,7	70	M12	20	CETOP 1" 1/2-400	60,1	M14	24
	2" SAE 3000	42,9	77,8	M12	20				

9.3ct

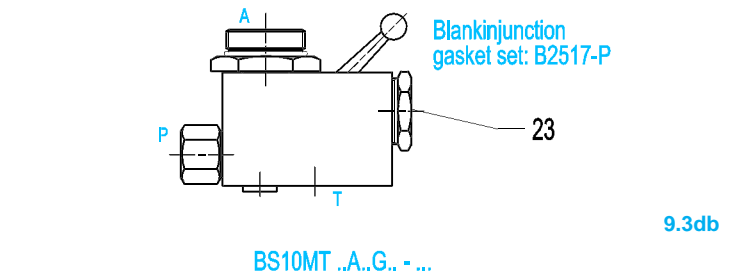
9.3.9.1 BS10 SPARE PARTS CODES



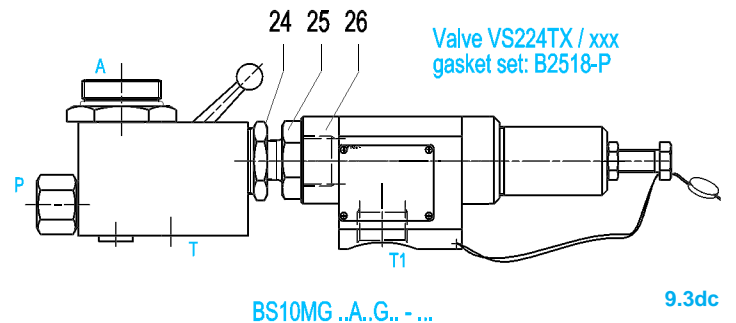
BS10MP ..A..G.. - ...

Item	Description	Q.ty	Order code
1	Body block BS10	1	Not supplied as spare part
2	Safety valve DBD ...10 k 1...	1	DBD... 10 k 1... 3/4" B10450-**
3	Niple side accumulator	1	1" 1/4 B10451-** 2" B10452-**
4	Niple installation side	1	B11855- **
5	Pin ball	1	B11856- **
6	Gasket	1	B11857- *
7	Washers stop end	1	B11858- C
8	Ball DN10	1	0052S906831RN
9	Spring pins 4x8 UNI 6873	1	0023E4x8C
10	Hex. socket head cap screws M4x10 UNI5931	1	0022VTCEIM4x10CZ
11	Large whaser Ø4x12x1 UNI 6593	1	0021RL4x12x1CZ
12	Whaser Ø10 UNI 6592	1	0021RP10CZ
13	Seal for ball Ø10	1	0013G914497RN
14	Seal for ball Ø10	1	0013G913112RN
15	Antiextrusion ring Parbak	1	0011P8012- *
16	"O" ring	1	0010R2037- *
17	"O" ring	2	0010M20x2- *
18	"O" ring	1	0010M12x2- *
19	"O" ring	1	0010R3150- *
20	Plug with rubber seals 1/4" BSP	1	0031TG2
21	Handle for BS10	1	B10100-A
22	Description plate	1	B11024- 6- A
23	Blankinjunction side accumulator plug	1	B2375- **/*
24	Adapter	1	B10456-C
25	Nipple	1	B11638-C
26	Valve VS 224 TX	1	VS224TX / xxx
27	Complete solenoid valve	1	Normally open B2372-xxx-O Normally closed B2395-xxx-C
28	Coil + connector	1	B2370-xxx
Standard nipple ass. (parts 3-17-19)		1	3/4" N-M221.5A5- **. * 1" 1/4 N-M221.5A7- **. * 2" N-M221.5A9- **. *
Safety block gasket sets		1	B 2140-*
Ball sets		1	B 2132-*

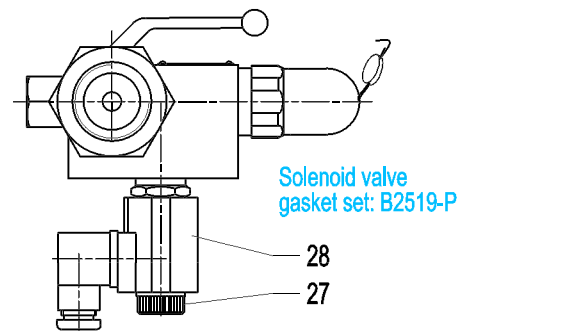
* Gasket material ** Component material



BS10MT ..A..G.. - ...



BS10MG ..A..G.. - ...

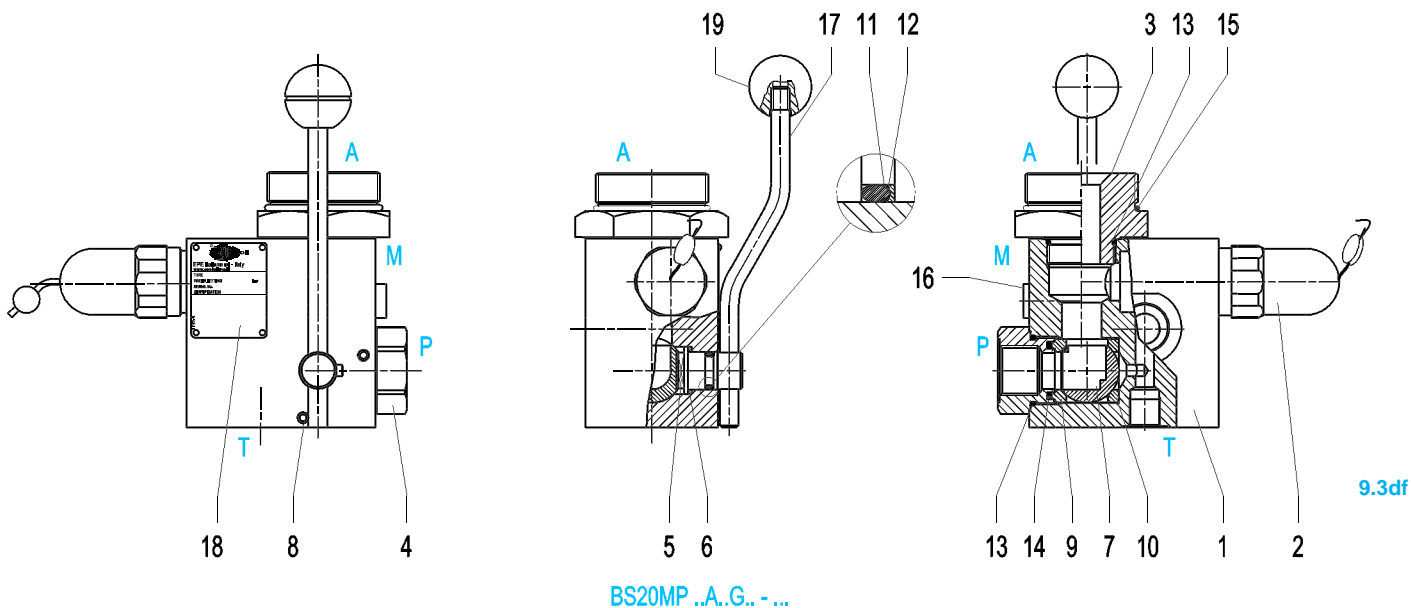


BS10EP ..A..G.. - ...

9.3de

9.3dd

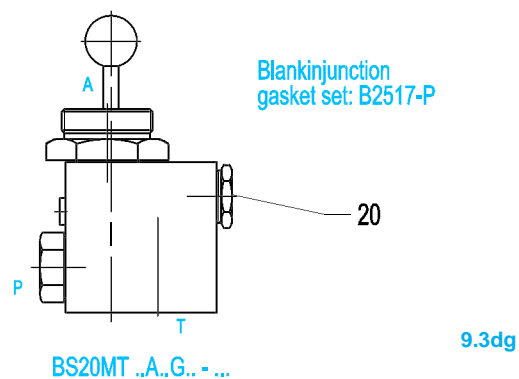
9.3.9.2 BS20 SPARE PARTS CODES



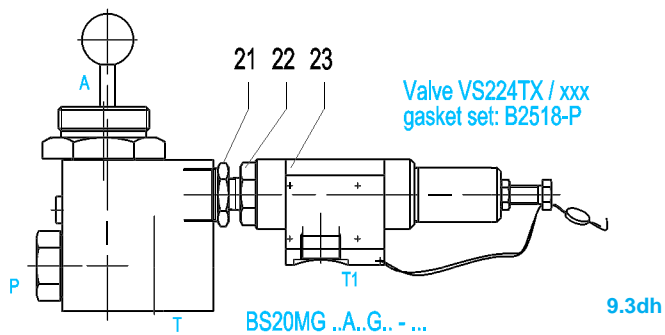
Item	Description	Q.ty	Order code
1	Body block BS20	1	Not supplied as spare part
2	Safety valve DBD... 10 k 1...	1	DBD... 10 k 1...
3	Niple side accumulator	1	1" 1/4 B10470 - ** 2" B10471 - **
4	Niple installation side	1	B10463 - **
5	Pin ball	1	B10462 - **
6	Gasket	1	B10487 - *
7	Ball DN20	1	0052S906356RN
8	Spring pins 6x26 UNI 6873	2	0023E6x26C
9	Seal for ball Ø20	1	0013G913911RN
10	Seal for ball Ø20	1	0013G914051RN
11	Antitrusion ring Parbak	1	0011P8113 - *
12	"O" ring	1	0010R0119 - *
13	"O" ring	2	0010R3131 - *
14	"O" ring	1	0010M24x3 - *
15	"O" ring	1	0010R3218 - *
16	Plug with rubber seals 1/4" BSP	1	0031TG2
17	Handle for BS20	1	B10482 - **
18	Description plate	1	B11024 - 6 - A
19	Knob M10	1	0055PS.35-M10-EA
20	Blankinjunction side accumulorg plug	1	B2375 - **/*
21	Adapter	1	B10456-C
22	Nipple	1	B11638-C
23	Valve VS 224 TX	1	VS224TX / xxx
24	Complete solenoid valve	1	Normally open B2372-xxx-O Normally closed B2395-xxx-C
25	Coil + connector	1	B2370-xxx
Standard nipple ass. (parts 3-13-15)		1	1" 1/4 N-M36/1.5A7 - **.* 2" N-M36/1.5A9 - **.*
Safety block gasket sets		1	B 2141 - *
Ball sets		1	B 2133 - *

* Gasket material ** Component material

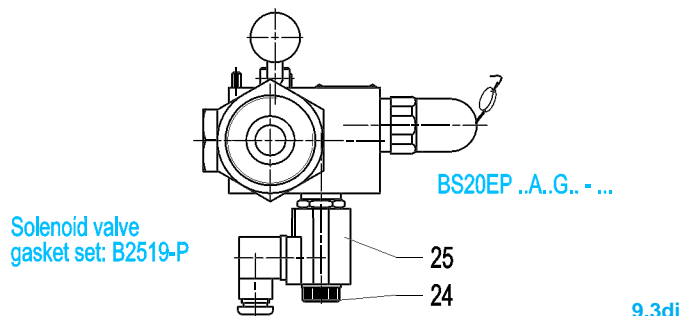
9.3dj



9.3dg

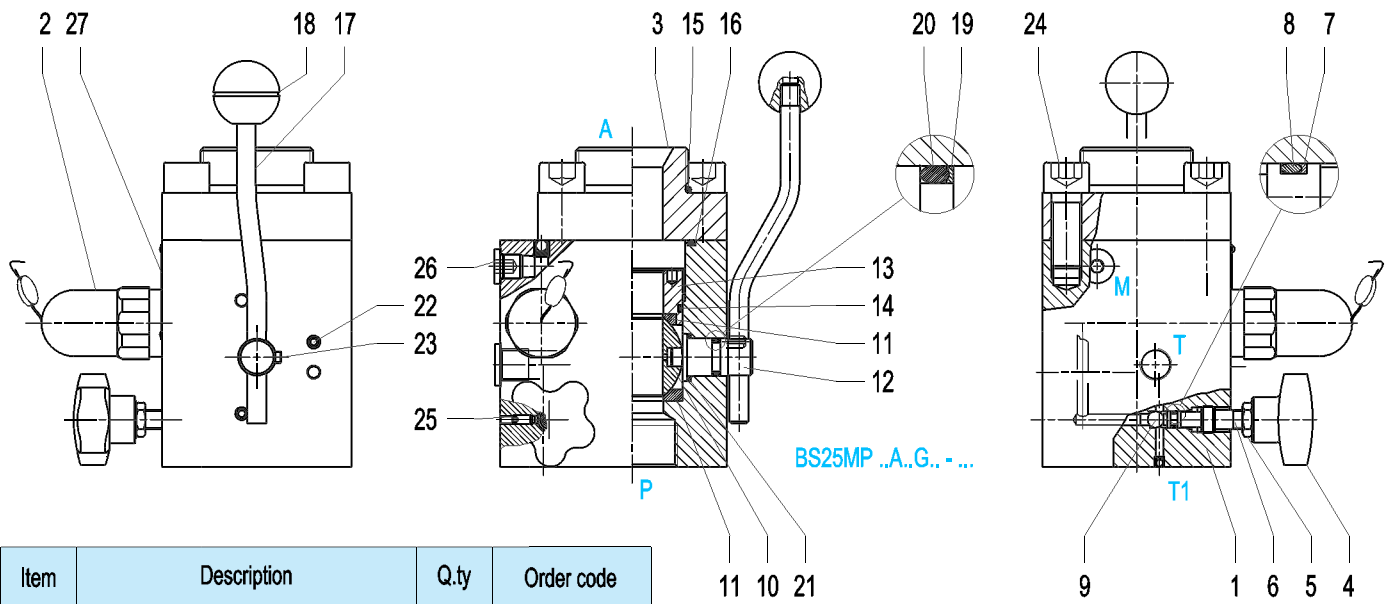


9.3dh



9.3di

9.3.9.3 BS25 SPARE PARTS CODES

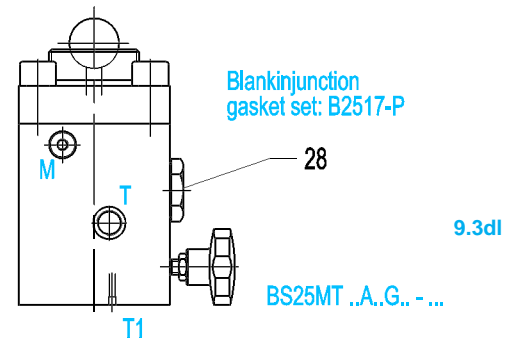


Item	Description	Q.ty	Order code
1	Body block BS25	1	Not supplied as spare part
2	Safety valve DBD... 10 k 1....	1	DBD... 10 k 1....
3	Flange accumulator side	1	1" 1/4 B10473 - ** 2" B10349 - 1 - **
4	Knob M10	1	055MVC.192/50B-M10EA
5	Hex. nut M10 UNI 5588	1	0020DNM10CZ
6	Manual discharge pin	1	B10417 - **
7	Antiextrusion ring Parbak	1	0011P8009 - *
8	"O" ring	1	0010R2021 - *
9	Ball Ø8.5	1	0051S8.5-C
10	Ball DN25	1	0052S906063RN
11	Seal for ball Ø25	2	0013G913912RN
12	Pin for ball	1	B10498 - **
13	Ring nut	1	B10494 - **
14	"O" ring	1	0010R3150 - *
15	"O" ring	1	0010R3218 - *
16	"O" ring	1	0010R0159 - *
17	Handle	1	B10482 - **
18	Knob M10	1	0055PS.35-M10-EA
19	Antiextrusion ring Parbak	1	0011P8113 - *
20	"O" ring	1	0010R0119 - *
21	Seal for pin	1	B10487 - *
22	Spring pin 6x26 UNI 6873	2	0023E6x26CZ
23	Set screw M6x8 UNI 5923-67	1	0022VSTEIM6x8CZ
24	Hex. socket head cap screws M16x40 UNI5931	4	0022VTCEIM16x40CZ
25	Set screw M5x12 UNI 5925-67	1	0022VSTEIM5x12CZ
26	Plug with rubber seal 1/4" BSP	1	0031TG2
27	Description plate	1	B11024 - 6 - A
28	Blankinjunction side accumulator plug	1	B2375 - ** / *
29	Adapter	1	B10456-C
30	Nipple	1	B11638-C
31	Valve VS 224 TX	1	VS224TX / xxx
32	Complete solenoid valve	1	Normally open B2372-xxx-O Normally closed B2395-xxx-C
33	Coil + connector	1	B2370-xxx
Standard flange accumulator assembly (parts 3 - 15 - 16)		1	1" 1/4 F 2454 A7 - ** / * 2" F 2454 A8 - ** / *
Safety block gasket sets		1	B 2142 - *
Ball sets		1	B 2134 - *

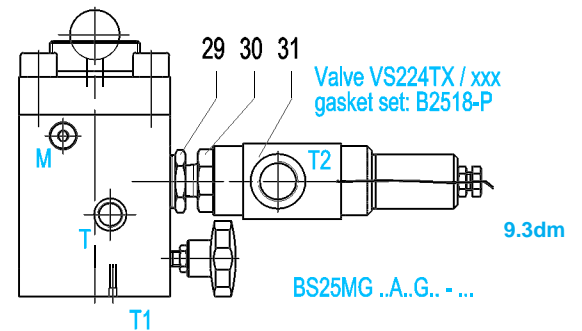
* Gasket material ** Component material

9.3do

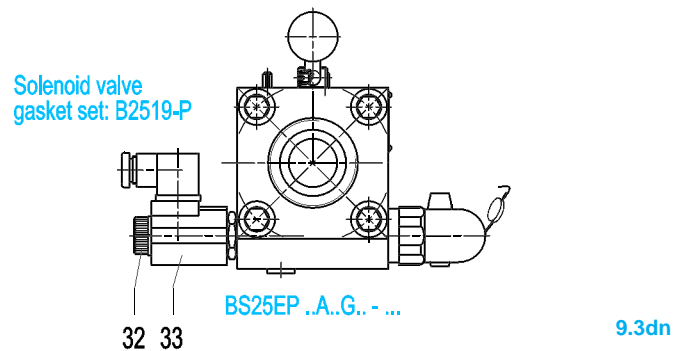
9.3dk



9.3dl

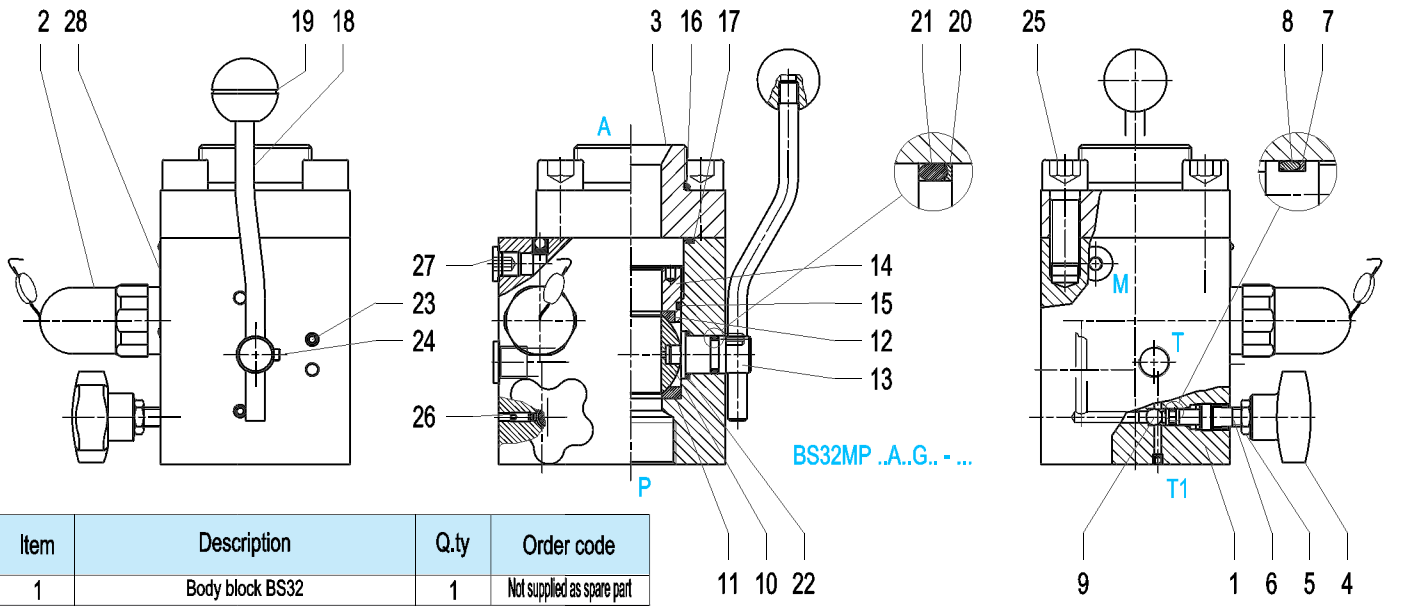


9.3dm



9.3dn

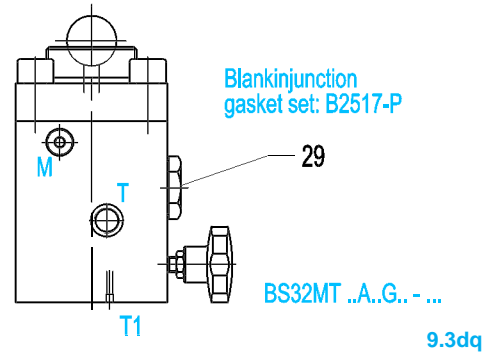
9.3.9.4 BS32 SPARE PARTS CODES



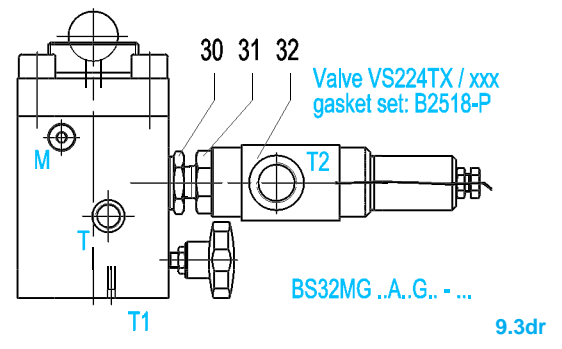
Item	Description	Q.ty	Order code
1	Body block BS32	1	Not supplied as spare part
2	Safety valve DBD... 10 k 1....	1	DBD... 10 k 1....
3	Flange accumulator side	1	2" B10349-1-**
4	Knob M10	1	055MVC.192/50BM10EA
5	Hex. nut M10 UNI 5588	1	0020DNM10CZ
6	Manual discharge pin	1	B10417 - **
7	Antiextrusion ring Parbak	1	0011P8009 - *
8	"O" ring	1	0010R2021 - *
9	Ball Ø8.5	1	0051S8.5-C
10	Ball DN32	1	0052S907744RN
11	Seal for ball Ø32	1	0013G913815RN
12	Seal for ball Ø32	1	0013G913813RN
13	Pin for ball	1	B10480R - **
14	Ring nut	1	B10478R - **
15	"O" ring	1	0010R3181 - *
16	"O" ring	1	0010R3218 - *
17	"O" ring	1	0010R0164 - *
18	Handle	1	B10482 - **
19	Knob M10	1	0055PS.35-M10-EA
20	Antiextrusion ring Parbak	1	0011P8113 - *
21	"O" ring	1	0010R0119 - *
22	Seal for pin	1	B10487 - *
23	Spring pin 6x26 UNI 6873	2	0023E6x26CZ
24	Set screw M6x8 UNI 5923-67	1	0022VSTEIM6x8CZ
25	Hex. socket head cap screws M16x40 UNI5931	4	0022VTCEIM16x40CZ
26	Set screw M5x12 UNI 5925-67	1	0022VSTEIM5x12CZ
27	Plug with rubber seal 1/4" BSP	1	0031TG2
28	Description plate	1	B11024 - 6 - A
29	Blankinjunction side accumulator plug	1	B2375 - ** / *
30	Adapter	1	B10456-C
31	Nipple	1	B11638-C
32	Valve VS 224 TX	1	VS224TX / xxx
33	Complete solenoid valve	1	Normally open B2372-xxx-C Normally closed B2395-xxx-C
34	Coil + connector	1	B2370-xxx
Standard flange accumulator assembly (parts 3 - 16 - 17)		1	2" F2454 A9 - ** / *
Safety block gasket sets		1	B 2143 - *
Ball sets		1	B 2135 - *

* Gasket material ** Component material

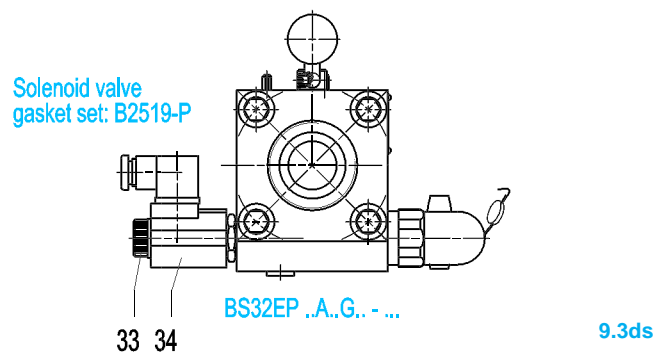
9.3dt



9.3dq



9.3dr



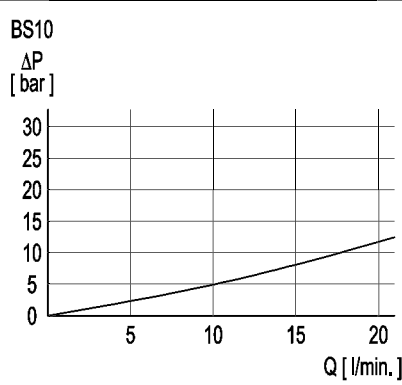
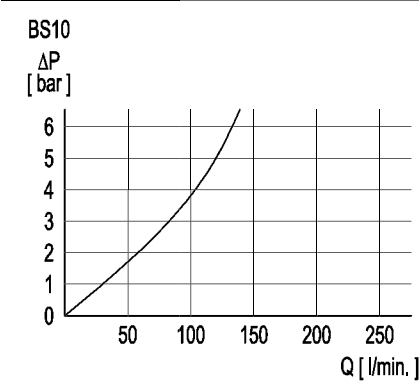
9.3ds

9.3.10 CHARACTERISTIC CURVES

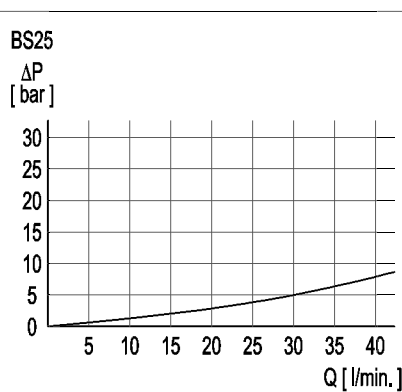
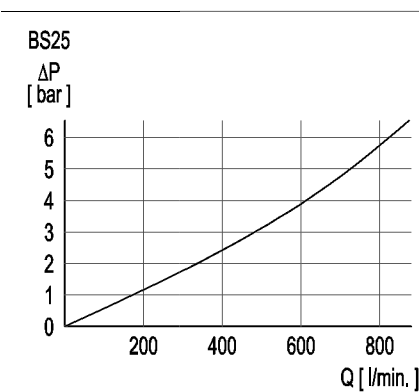
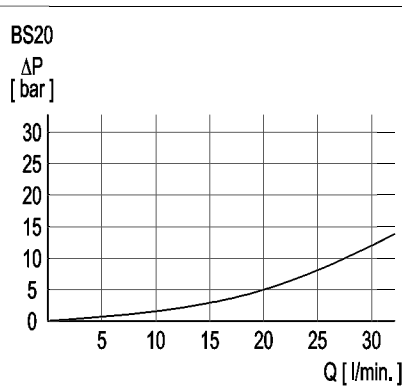
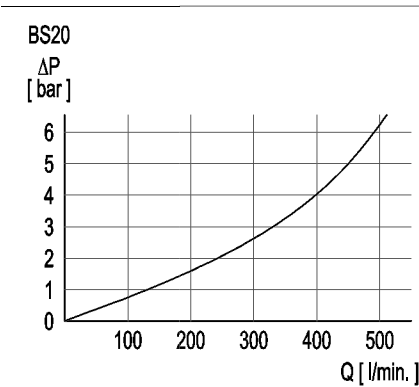
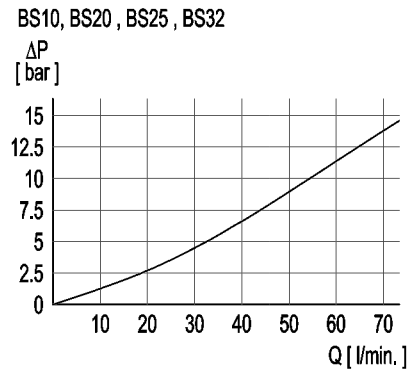
ΔP Curves

Flow rate from line to the accumulator and viceversa

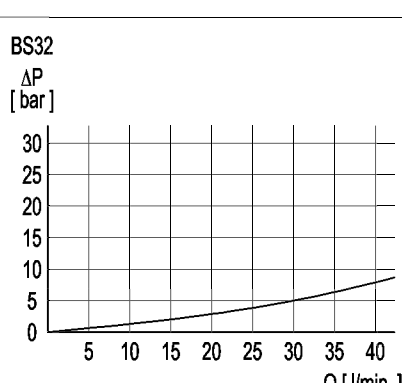
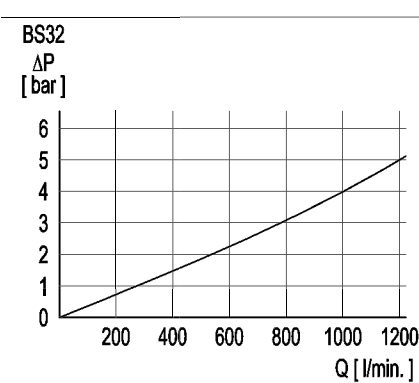
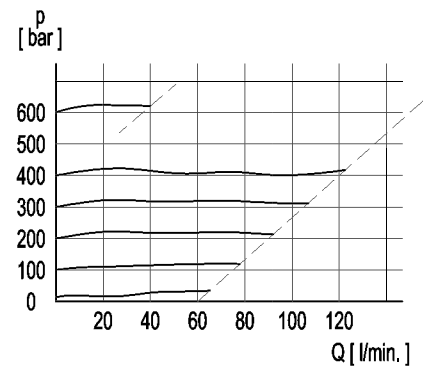
Flow rate from the accumulator to the tank



Flow rate from the accumulator via the solenoid valve to the tank



Flow rate from pressure relief valve to tank (only DBDS10)



Curves measured using mineral oil with viscosity of 36 cSt at 50°C

9.3.11 EUROPEAN MARKET

Directive 97/23/EC provides that pressure equipment, in which it's reasonably expected to be exceeded the allowable limits, should be provided with adequate protective equipment; for example, safety accessories such as the valves or the safety blocks type DBDS or BS. These devices shall prevent that pressure permanently exceeds the maximum allowable pressure PS of the equipment protected by them. However, it is permissible a pressure peak of short duration limited to 10% of the maximum allowable pressure. For the choice and sizing of the adequate safety device, the User should refer to specific standards. In accordance with the regulations 97/23/EC, the safety valves are classified in Category IV.

9.3.12 ACCESSORIES

For safety valve type VS, see section 8.1

For safety valve type DBDS, see section 9.1

For fluid side adapter, see section 9.4

For single acting flow control valves, see section 12.5

Reproduction is forbidden.

In the spirit of continuous improvement, our products may be changed.

9.4.1 TECHNICAL DATA

INTERNAL DIAMETER: 30 mm

MAX OPERATING PRESSURE (PS): 400 BAR

WORKING TEMPERATURE):

- 20 ÷ 80 °C ("P" version with NBR seals)
- 10 ÷ 150 °C ("V" version with VITON seals)

MATERIAL: phosphated or galvanized carbon steel in compliance with Directive 2002/95/EC (RoHS) to resist to corrosion
- stainless steel

WEIGHT: see Table 9.4d



9.4a

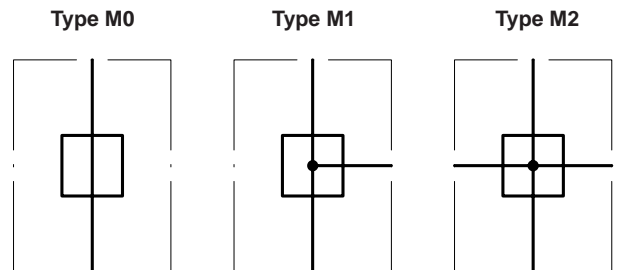
9.4.2 ADVANTAGES

- compact design
- flexible connection options

9.4.3 DESCRIPTION

The gas side adapters are blocks of various type, which can be mounted on the fluid side of an accumulator and which can fit the safety block. Special seal allows this adapter to be installed simply and securely in any position on all fluid valves of the bladder or piston accumulators. It's important to select the correct adapter based on the correct thread fluid valve and the connection of installation side.

9.4.4 HYDRAULIC SYMBOL



9.4b

9.4.5 ORDER CODE

1	2	3	4	5	6	7	8
TF	G	8	A	8	M1	-	C P

1 Series	
Gas side adapter	= TF

2 Up connection	
Thread BSP 150228 male	= G
Adapter SAE 3000	= L
Adapter SAE 6000	= H

3 Dimension of up connection	
1 1/2"	= 8
2"	= 9

4 Bottom connection	
Thread BSP ISO 228 with chamfer for OR	= A
Adapter SAE 3000 without OR	= L
Adapter SAE 6000 without OR	= H

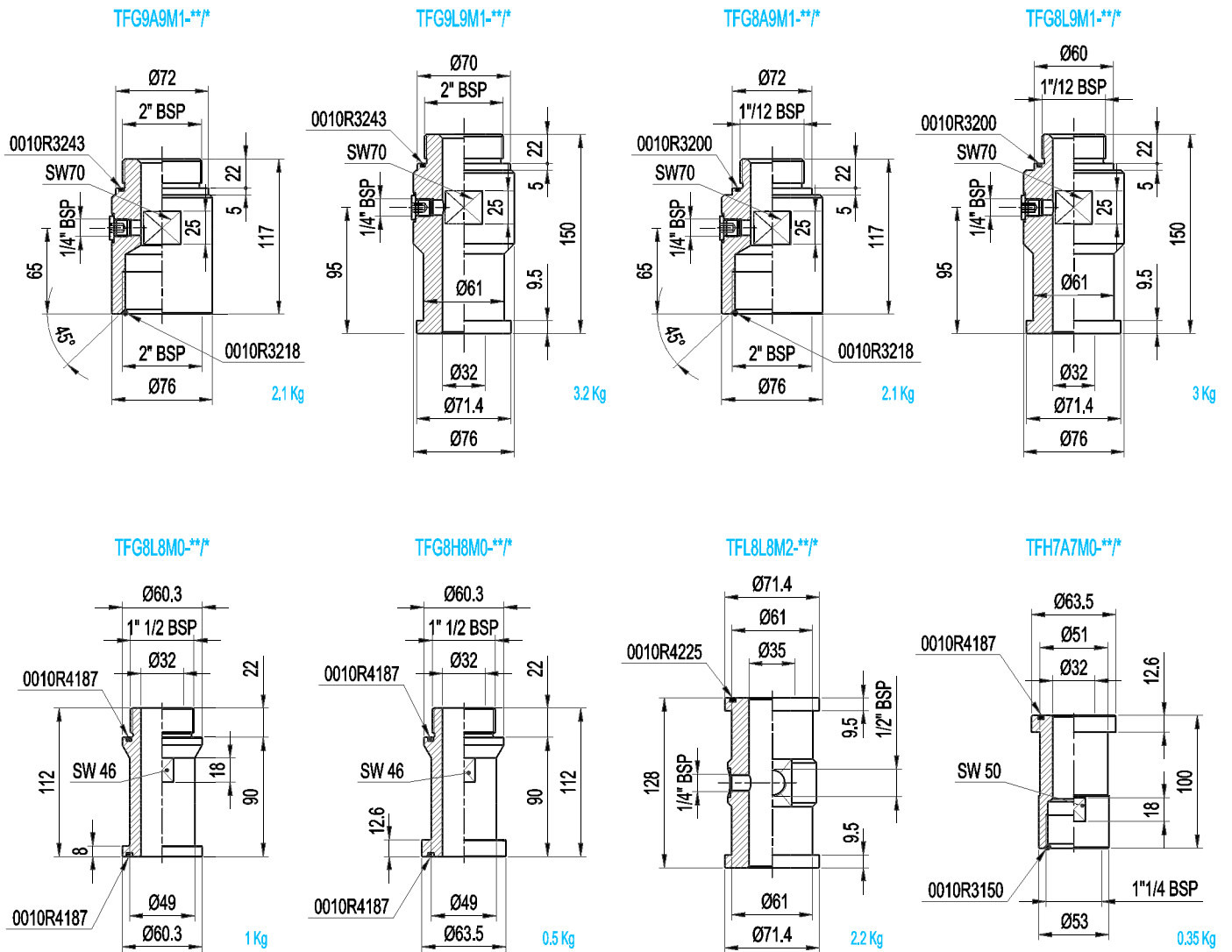
8 Seal material	
Nitrile (NBR)	= C
Viton (FKM)	= V

7 Block material	
Carbon steel	= C
Nickel coating 25 μ	= N
Nickel coating 40 μ	= M
Stainless steel	= X

6 Lateral connection	
Without connection 1/4"	= M0
1 connection 1/4" BSP plugged	= M1
2 connections 1/4" BSP plugged	= M2

5 Dimension of bottom connection	
1 1/2"	= 8
2"	= 9

9.4.6 DIMENSIONS



9.4c

Reproduction is forbidden.
 In the spirit of continuous improvement, our products may be changed.



ACCUMULATORS STATIONS type BA

10.1



EXAMPLES OF BLADDER ACCUMULATOR STATIONS

10.2



EXAMPLES OF BLADDER WITH ADDITIONAL BOTTLE STATIONS

10.3



EXAMPLES OF PISTON ACCUMULATOR STATIONS

10.4



EXAMPLES OF PISTON WITH ADDITIONAL BOTTLE STATIONS

10.5



EXAMPLES OF ADDITIONAL BOTTLE STATIONS

10.6

10.1.1 DESCRIPTION

Epe Italiana supplies fully assembled accumulator stations which are ready for operation and complete with the necessary ball valve controls and safety equipment

- as an individual accumulator unit or
- in a back-up version with nitrogen bottles to increase the effective volume.

Nitrogen bottles, used as back-up, increase the gas volume inside the accumulator. This means that smaller accumulators can be used for the same gas volume and costs can be reduced.

An accumulator station can be composed of:

- single piston accumulator with support frame and instrumentations
- piston accumulators with nitrogen bottles.
- only bladder accumulators connected together by fluid side with manifold
- bladder accumulators with nitrogen bottles. In this version, the bladder accumulator must be of AST type (transfer) where the gas side is designed especially for connection to nitrogen bottles. Internal diffuser rod prevents damage to the bladder when the accumulator is full of fluid.
- nitrogen bottles alone.

Each accumulation station can be customized according to customer requirements/ technical specifications, painting included.

Epe Italiana can provide the complete group with all accessories such as pressure gauges, pressure switches, transducers, as well as safety accessories; all hydraulically connected to pipes in carbon steel or stainless steel and fittings free from leaks. In addition, all electrical equipment can be wired and connected to the terminal board. For this reason, all the accumulator stations have the order code followed by the specific drawing that incorporates the dimensional drawing, the hydraulic and electric chart and, of course, the list of components and any nameplate. For the selection of the individual components and specifications, please refer to the relevant catalogue.



10.1b



10.1a



10.1c

10.1.2 ORDER CODE

1	2	3	4	5	6	7
BA	1	/	4	P	400	A 105...

1	Series
Accumulator station	= BA

2	No. of accumulators (if any)
Examples	1 = 1 2 = 2 3 = 3 4 = 4 5 = 5 ... = ... 16 = 16

3	No. of additional bottles (if any)
Examples	1 = 1 2 = 2 3 = 3 4 = 4 5 = 5 ... = ... 16 = 16

Special versions on request

7	Drawing number
Drawing number assigned by EPE after the PO:	
accumulator station with bladder accumulator/s	= 102...
accumulator station with bladder accumulator/s + additional cylinders	= 103...
accumulator station with piston accumulator/s	= 104...
accumulator station with piston accumulator/s + additional cylinders	= 105...
accumulator station with additional cylinders	= 106...

6	Assembly drawing
Assembly drawing	= A

5	Total volume of nitrogen "Vo" in liters
Total volume of nitrogen in the accumulator station	= ...

4	Type of the station
With piston accumulator	= P
With bladder accumulators	= S
With additional bottles	= B

Reproduction Is Forbidden.

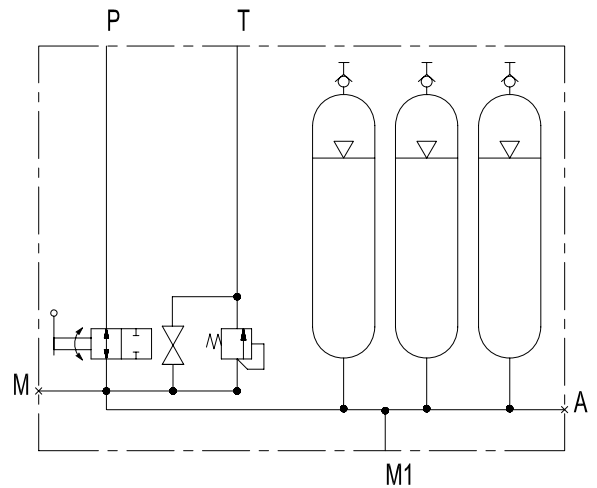
In The Spirit Of Continuous Improvement, Our Products May Be Changed.

10.2.1 EXAMPLES OF BLADDER ACCUMULATOR STATION

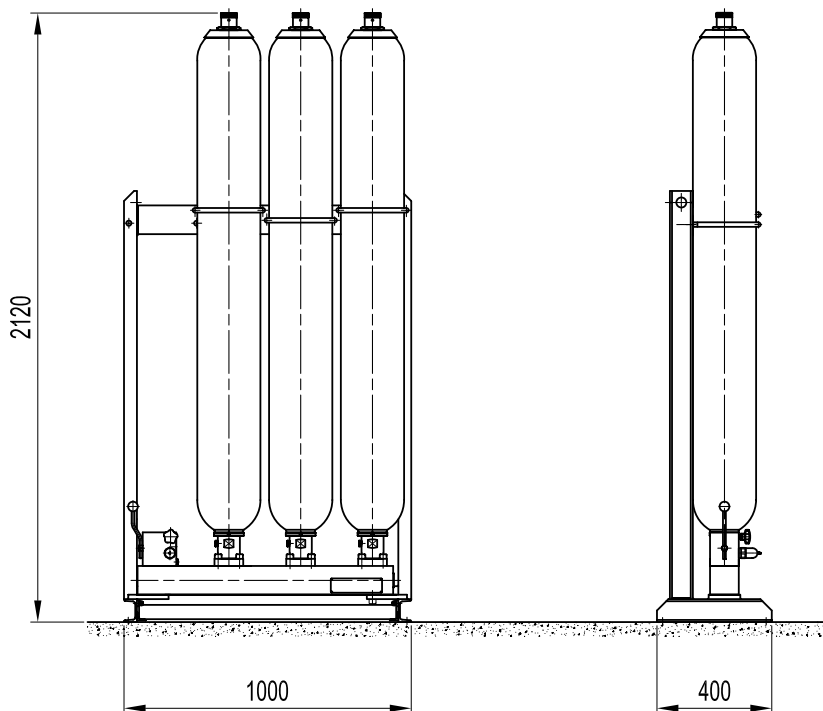


10.2a

HYDRAULIC DIAGRAM



10.2b

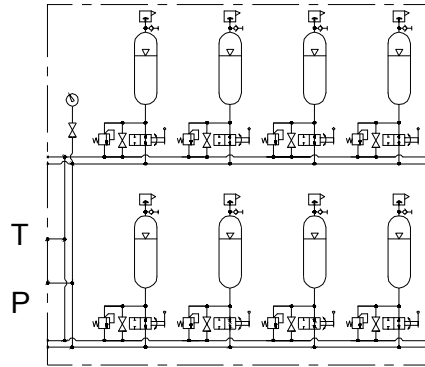


10.2c

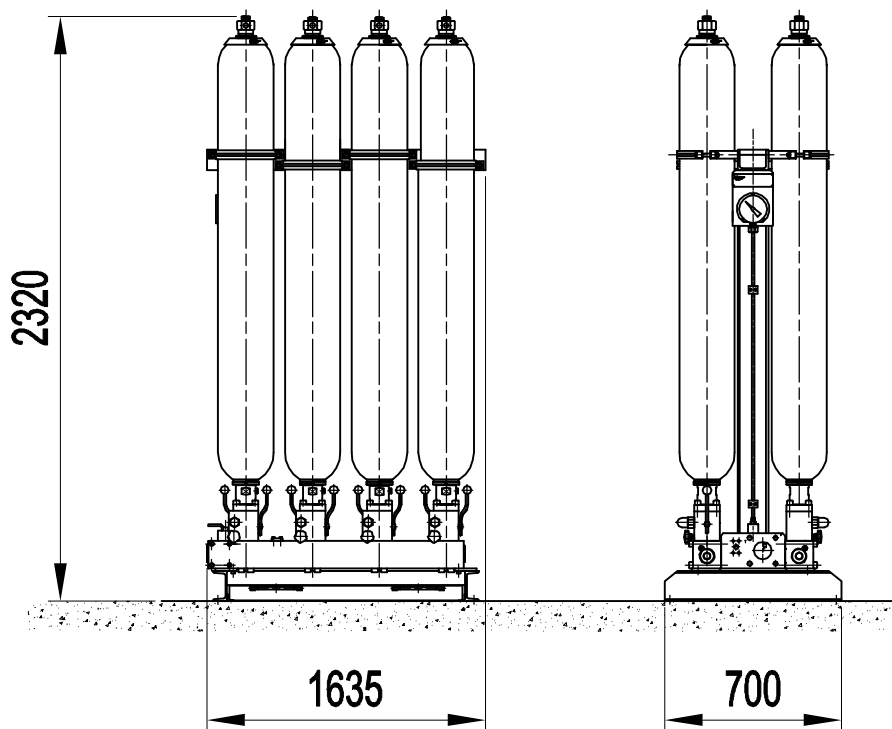


10.2d

HYDRAULIC DIAGRAM



10.2e



Reproduction is forbidden.

In the spirit of continuous improvement, our products may be changed.

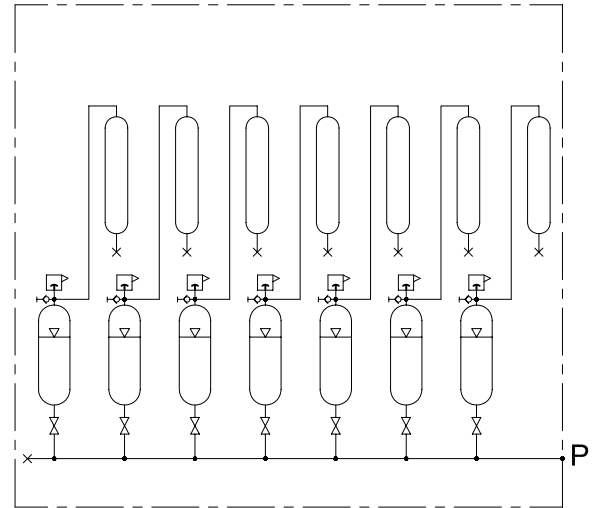
10.2f

10.3.1 EXAMPLES OF BLADDER ACCUMULATOR STATION

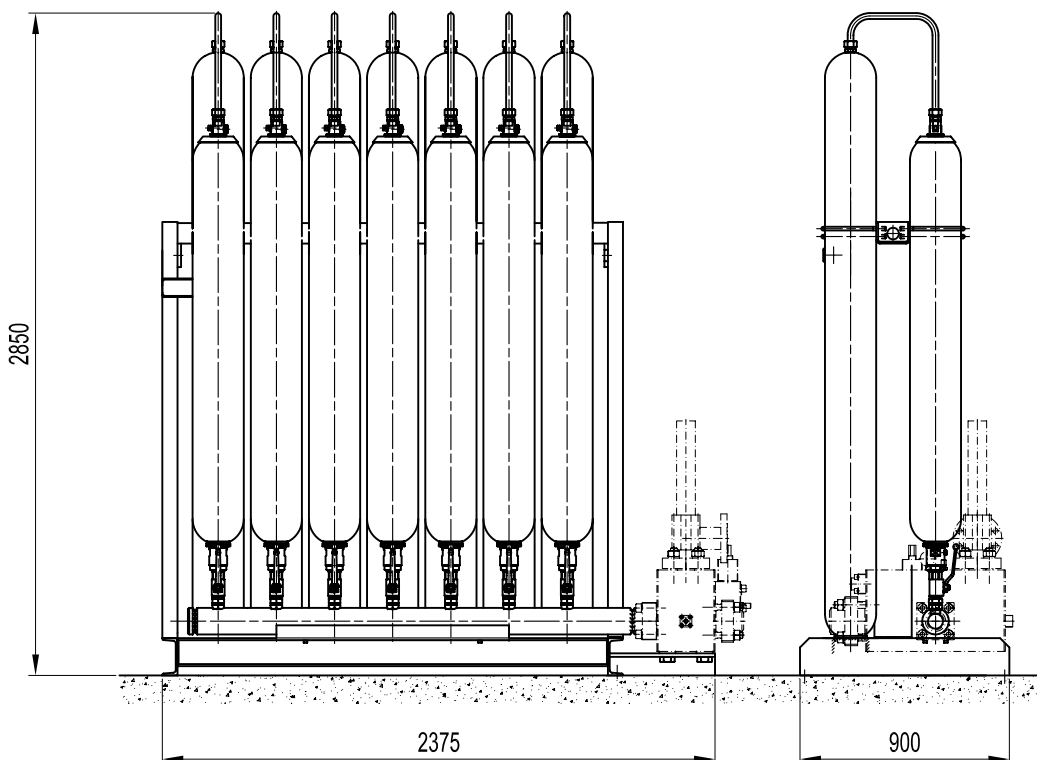


10.3a

HYDRAULIC DIAGRAM



10.3b

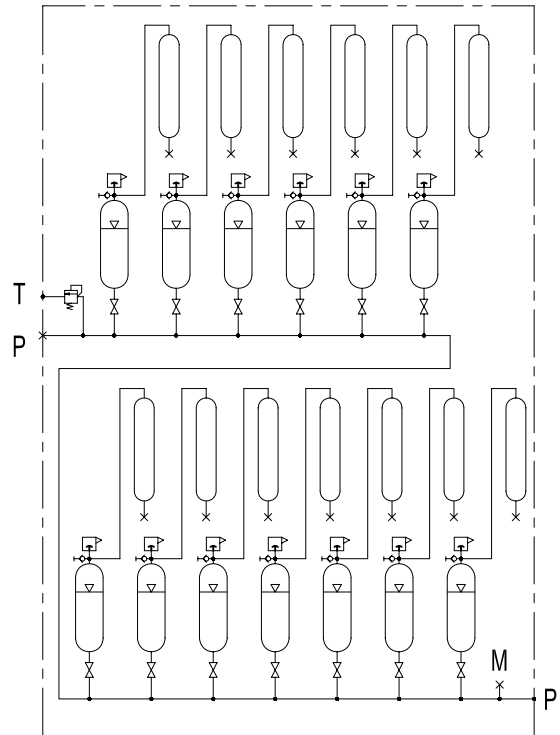


10.3c

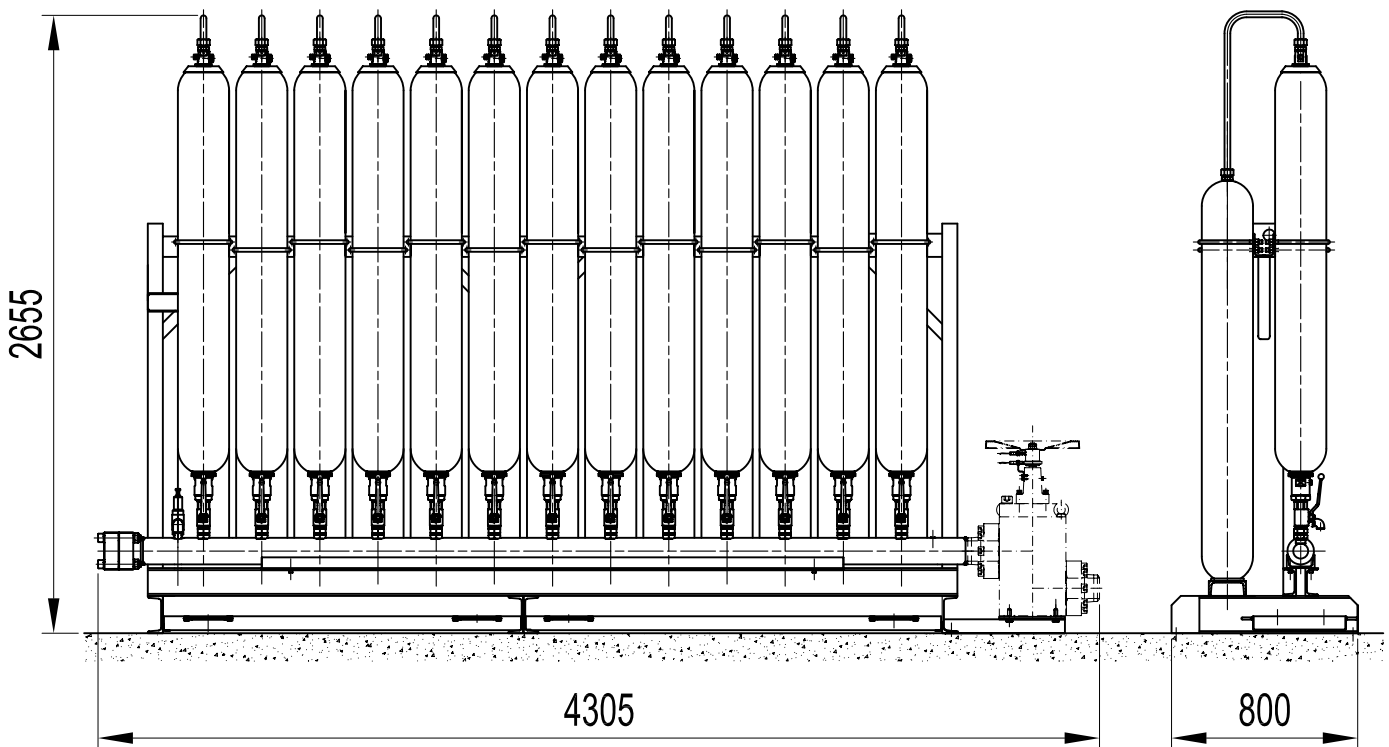


10.3d

HYDRAULIC DIAGRAM



10.3e



10.3f

Reproduction is forbidden.

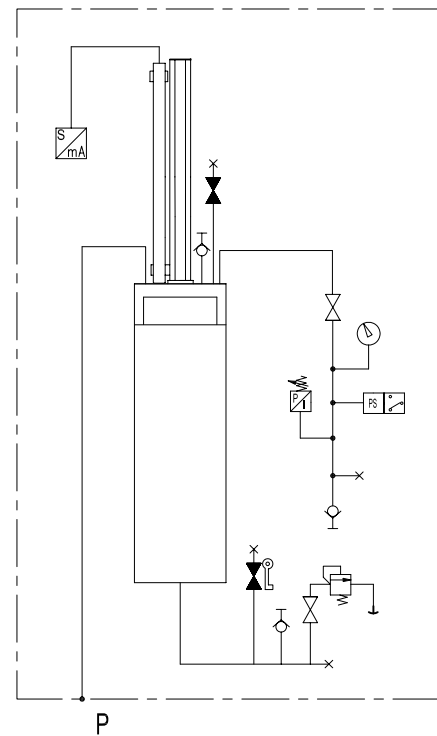
In the spirit of continuous improvement, our products may be changed.

10.4.1 EXAMPLES OF PISTON ACCUMULATOR STATION

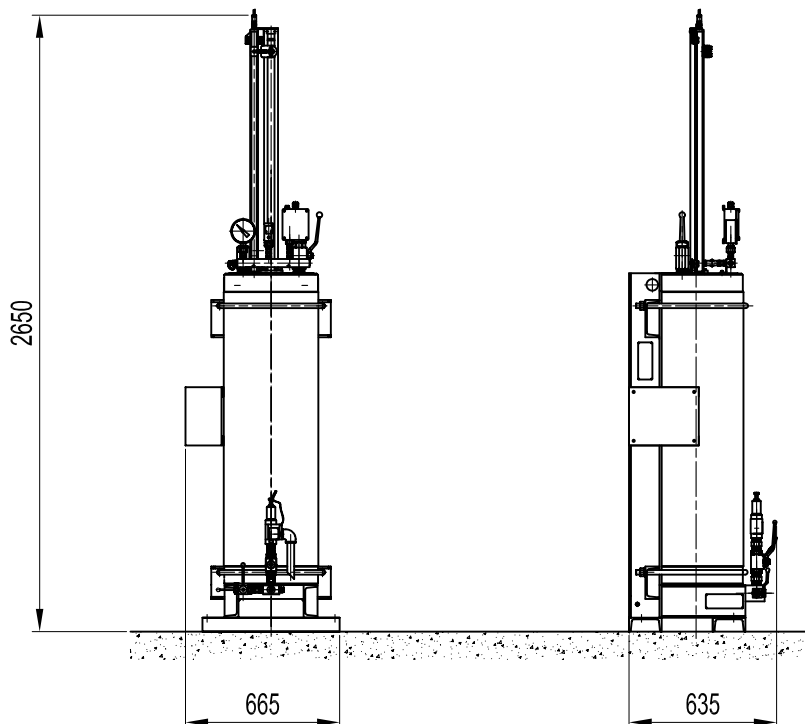


10.4a

HYDRAULIC DIAGRAM



10.4b

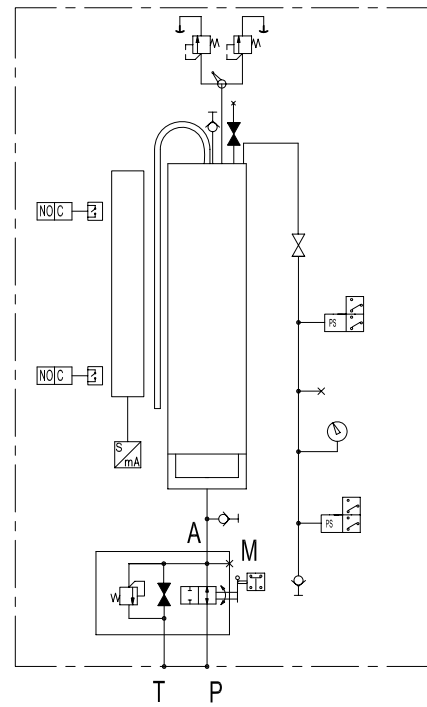


10.4c

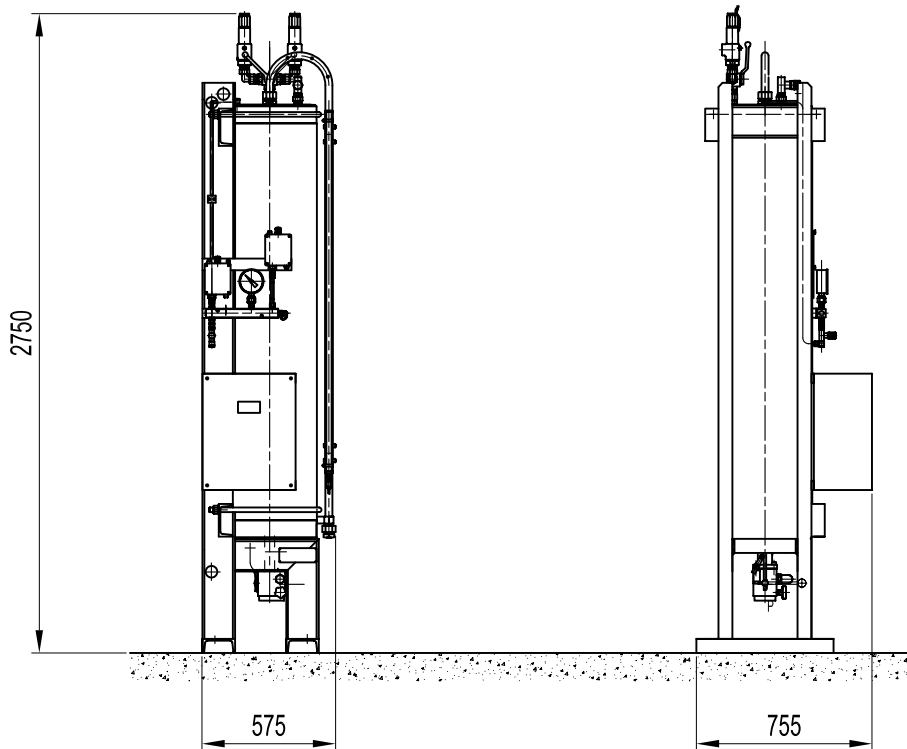


10.4d

HYDRAULIC DIAGRAM



10.4e



Reproduction is forbidden.

In the spirit of continuous improvement, our products may be changed.

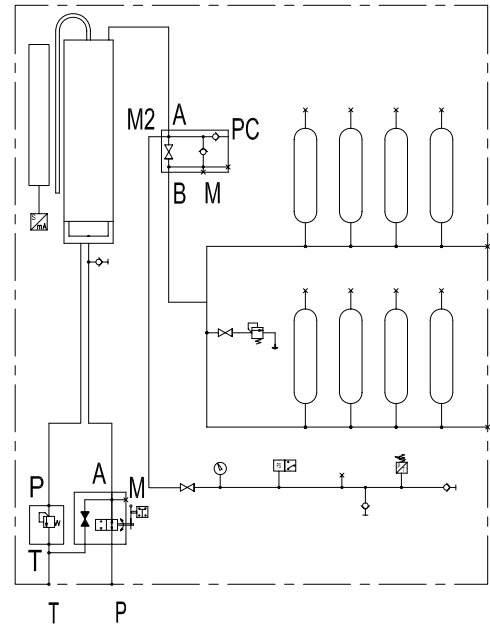
10.4f

10.5.1 EXAMPLES OF PISTON AND ADDITIONAL BOTTLE STATION

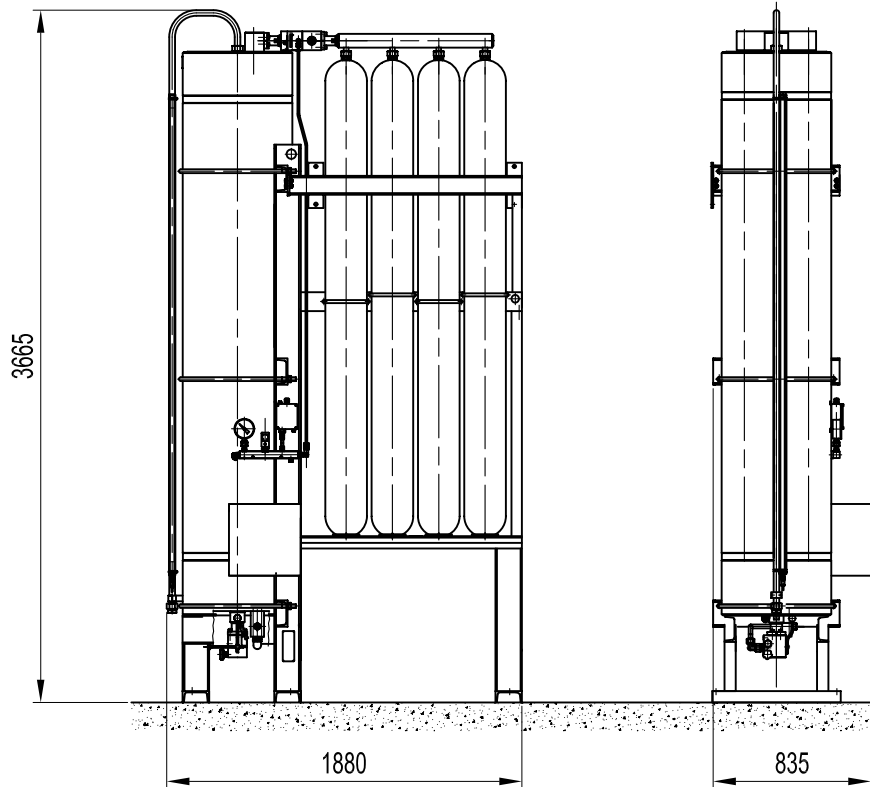


10.5a

HYDRAULIC DIAGRAM



10.5b

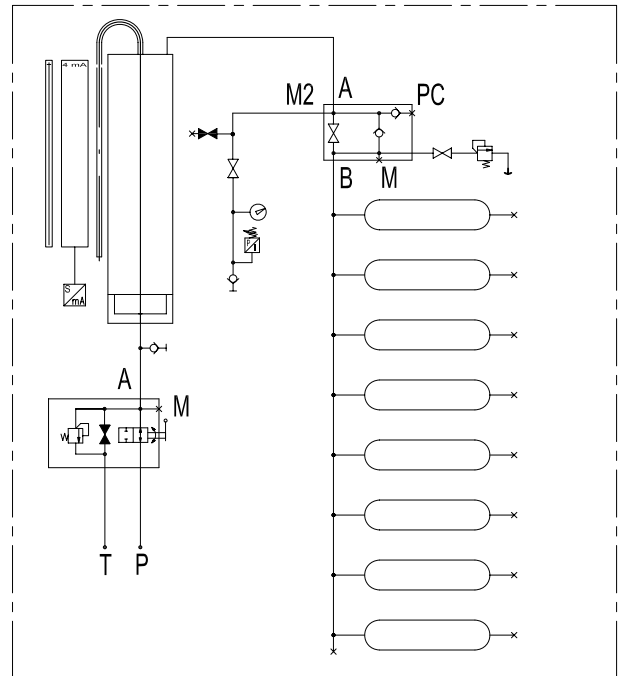


10.5c

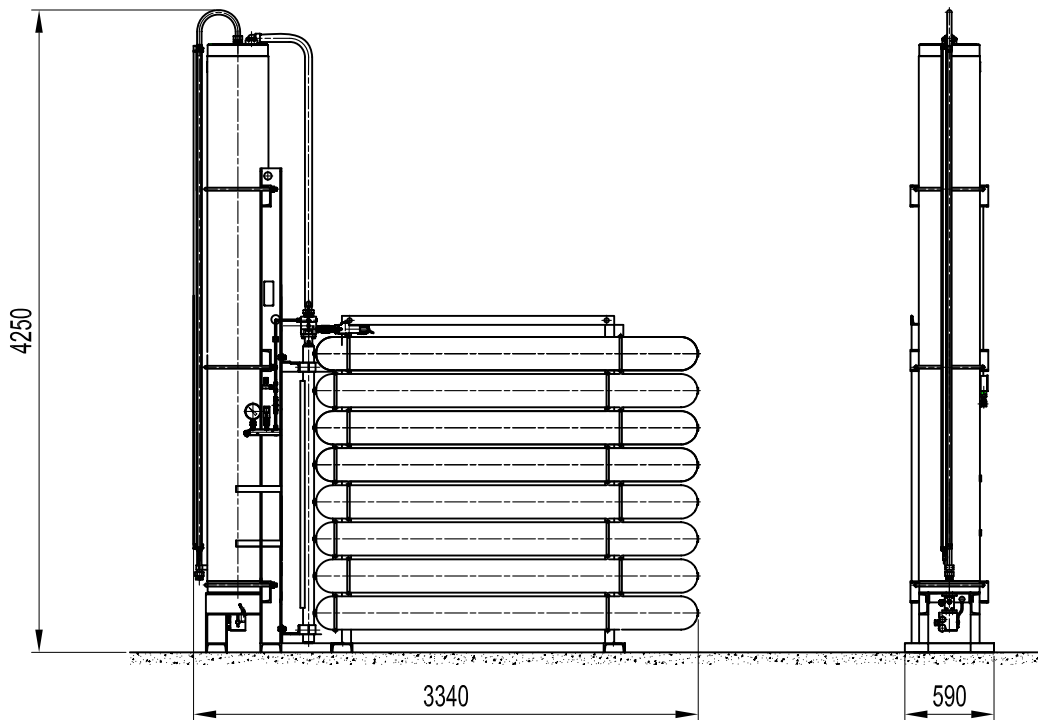


10.5d

HYDRAULIC DIAGRAM



10.5e



Reproduction is forbidden.

In the spirit of continuous improvement, our products may be changed.

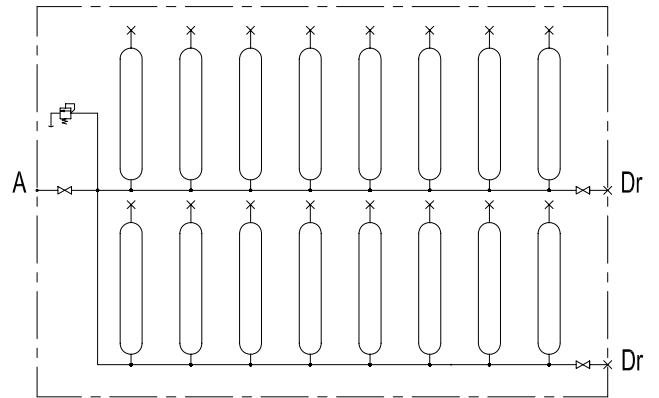
10.5f

10.6.1 EXAMPLES OF ADDITIONAL BOTTLE STATION

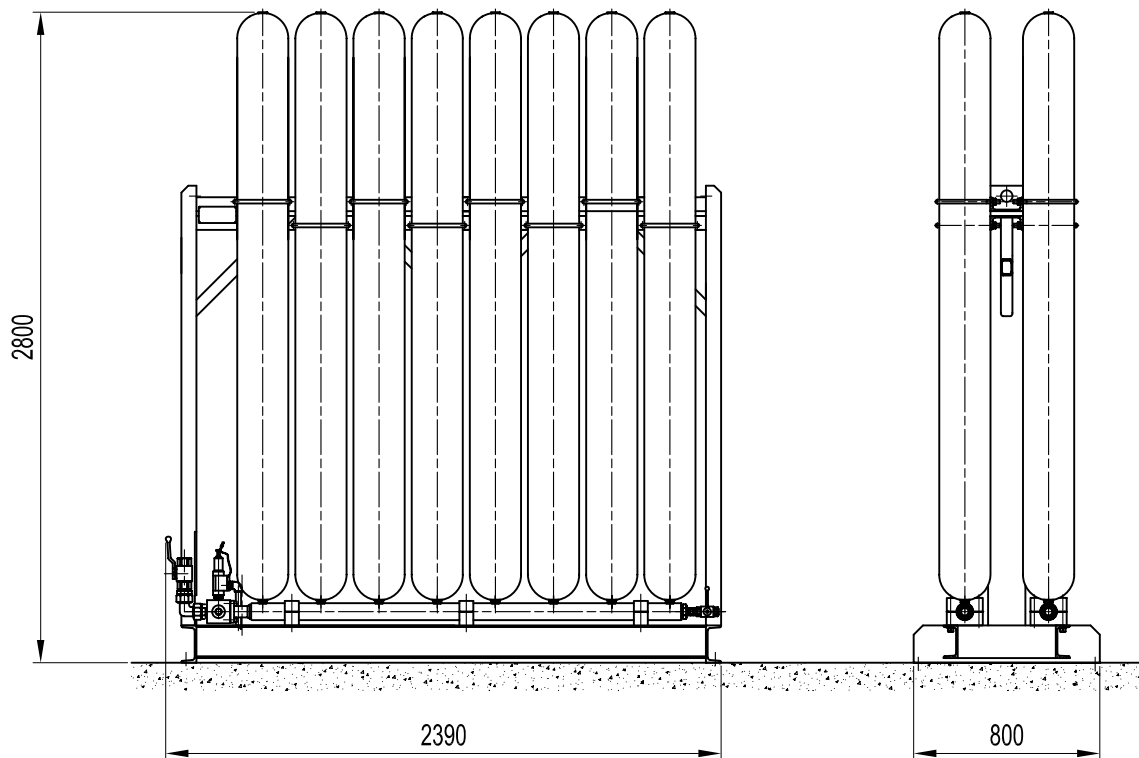


10.6a

HYDRAULIC DIAGRAM



10.6b

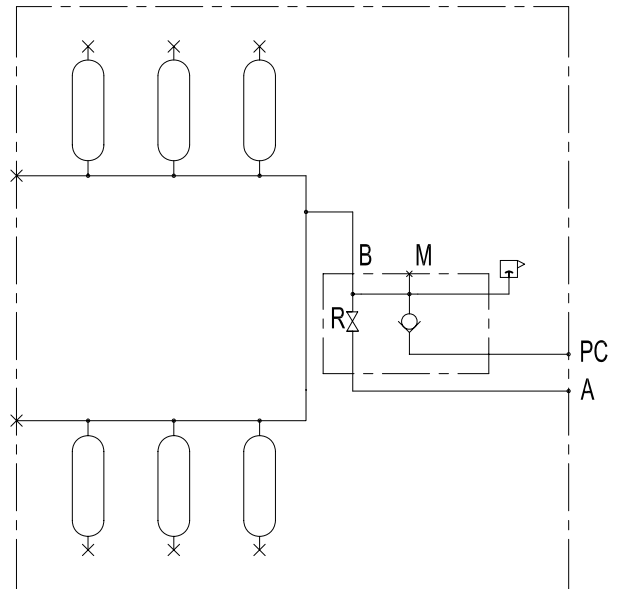


10.6c

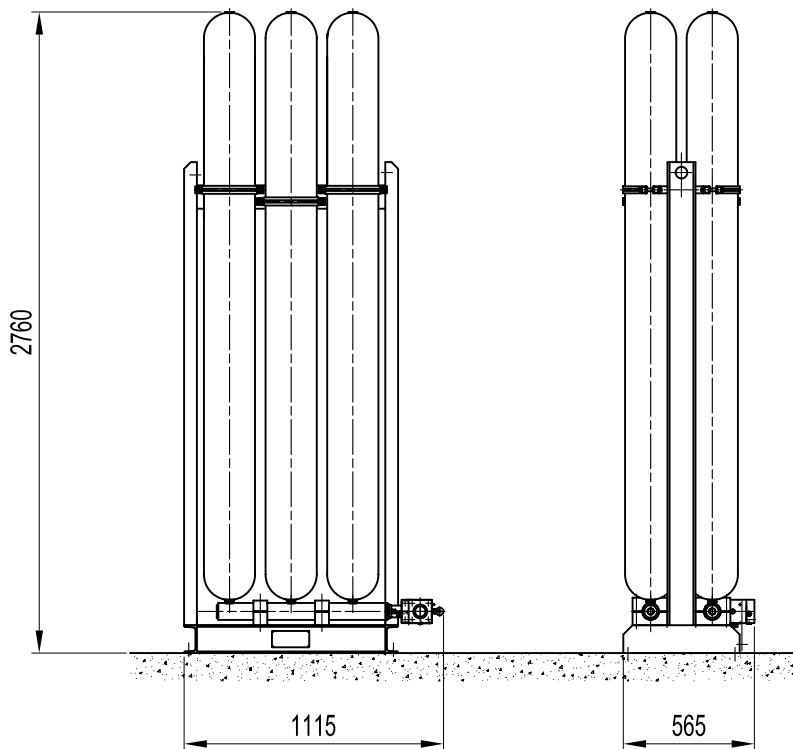


10.6d

HYDRAULIC DIAGRAM



10.6e



10.6f

Reproduction is forbidden.

In the spirit of continuous improvement, our products may be changed.



NITROGEN CHARGING KIT type PC

11.1



NITROGEN CHARGING KIT type PCM

11.2



PRESSURE REDUCER type B2494

11.3



MOBILE NITROGEN CHARGING UNIT type CCA 9/350

11.4

11.1.1 TECHNICAL DATA

MAX OPERATING PRESSURE (PS): 600 BAR

PRESSURE TEST (PT): 1.43 x PS

SCALE OF PRESSURE GAUGE:

4 - 10 - 16 - 25 - 60 - 100 - 250 (std.) - 400 - 600 bar

WORKING TEMPERATURE: - 20 ÷ +80°C

MEDIUM: Nitrogen

NITROGEN CONTAMINATION DEGREE:

class 20/18/15 according to ISO 4406/99

BODY MATERIAL: phosphated carbon steel or galvanized carbon steel in compliance with Directive 2002/95/EC (RoHS) to resist to corrosion

SEALS MATERIAL: P = Nitrile rubber (NBR) and Delrin

FILLING VALVE CONNECTION: 5/8" UNF + adapters (upon request)

WEIGHT: 1.8 Kg. (complete with case)

11.1.2 DESCRIPTION

The charging and gauging assembly consists of 3 mt. charging hose with standard nitrogen nipples, body incorporating gas valve connection, bleed valve and check valve. These kits are packed in a plastic storage case. Gauge is diameter 63 mm. diam type pressure gauges with 0÷250 bar graduation. The following charging kit are recommended to be used on all piston accumulators (with standard filling valves V or VX), on all bladder accumulators, on screwed and forged diaphragm accumulators. It is used for the periodic check of accumulator pre-charge and for the inflation of accumulators after the maintenance or it is used for the change of pre-charge value. For the inflation, it is necessary a connection to a bottle filled with industrial dry nitrogen with a pressure higher than the pre-charge value required, provided with pressure reducer (mandatory, for safety reasons, during the inflation of accumulators with PS < 210 bar).

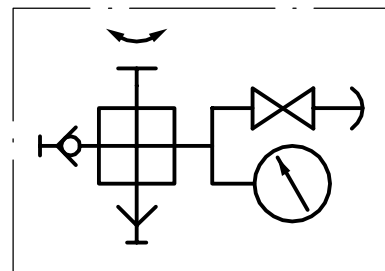
Furthermore, the use of a pressure reducer makes easier the slow and graduated inflow of nitrogen on the bladder, thus avoiding the possibility of damaging the bladder itself.

NOTE: These assemblies are not recommended for continuous monitoring of gas pre-charge. For continuous monitoring, see Gas Adapters at Section 8.3



11.1a

11.1.3 HYDRAULIC SYMBOL



11.1b

11.1.4 CONSTRUCTION

STANDARD VERSION includes:

- Valve body complete with ring nut connection to accumulator gas valve, pressure gauge, bleed and non return snap-in hose connection.
- 3 mt charging hose for high pressure series complete with bottle connection.
- Set of spare gaskets.
- Case.

UPON REQUEST:

- Nipple for to pressure reducer.
- ADAPTERS for special accumulator gas valves.
- CHARGING HOSE with length of 1 - 4 - 6 mt.

11.1.5 ORDER CODE

1	2	3	4	5
PC	250	S	1	-

1	Series
	Pre-loading and checking = PC

2	Scale of pressure gauge (bar)
	0 ÷ 4 = 4
	0 ÷ 10 = 10
	0 ÷ 16 = 16
	0 ÷ 25 = 25
	0 ÷ 60 = 60
	0 ÷ 100 = 100
	0 ÷ 250 = 250 (standard)
	0 ÷ 400 = 400
	0 ÷ 600 = 600

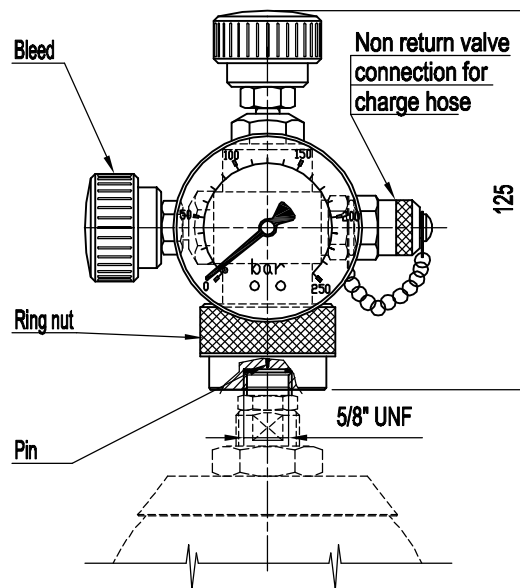
3	Filling valve connection
	5/8" UNF = S (standard)
	VG8 (Ø 7.7 x 1/32") = A
	7/8" UNF = B
	1/4" BSP ISO 228 = C
	VG8 (Ø 7.7 x 1/32") long thread = D
	7/8" UNF with pin = E

5	Charging hose (meters)
	Standard 3 mt = -
	1 mt = C
	4 mt = M
	6 mt = L

4		Connection to bottle (according to Country standards)
Italy	= 1	Indonesia
Austria	= 2	Ireland
Czech Republic		Jamaica
Denmark		Kenya
Finland		Malaysia
Germany		Malta
Netherlands		New Zealand
Norway		Pakistan
Poland		Portugal
Sweden		Singapore
Switzerland		Sri Lanka
Belgium	= 3	Sudan
Algeria		Tanzania
Bahrain		Thailand
Bulgaria		Turkey
Egypt		Vietnam
France		Zambia
Gabon	= 5	Brazil
Guinea		Puerto Rico
Hungary	= 6	South Africa
Iran		Philippines
Iraq	= 7	Canada
Israel		U.S.A.
Ivory Coast	= 8	Albania
Jordan		Russia
Kuwait		Venezuela
Libya	= 9	Japan
Mauritius	=10	Taiwan
Mexico	=11	China
Morocco	=12	Korea
Mozambique	=13	Bolivia
Nigeria		Chile
Oman		Colombia
Qatar		Dominican Republic
Romania		Ecuador
Saudi Arabia		Guatemala
Slovenia		Guyana
Spain		Honduras
Syria		Paraguay
Tunisia		Peru
United Arab Emirates		Uruguay
Argentina	= 4	
Bahamas		
Barbados		
Costa Rica		
Cyprus		
Ethiopia		
Gambia		
Ghana		
Great Britain		
Greece		
Hong Kong		
India		

Special variants on request

11.1.6 DIMENSIONS



11.1c

11.1.7 SPARE PARTS CODE

Spare parts	number code
Complete PC body with manometer	B2156/*
PC body without manometer	B2157
Manometer	B2163/*
Flexible hose of 1 meter	B2166/1
Flexible hose of 3 meters (standard)	B2166/3
Flexible hose of 4 meter	B2166/4
Flexible hose of 6 meter	B2166/6
Complete central pin	B2165
Complete bleed	B2164
Non return valve	B2162
Seals kit	B2160/**
Seal face for filling valve	B10342 D

* = see scale of pressure gauge at Section 11.1.4

** = see table 11.1h for country codes

11.1d

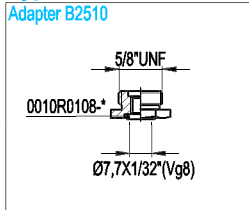
11.1.8 ACCESSORIES

Adapters

All adapters represented below serve to use the EPE pre-charge equipment on the accumulators of the main international manufacturers.

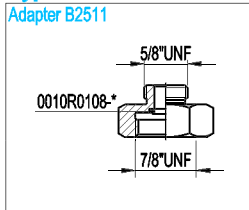
Type "A"

Adapter B2510



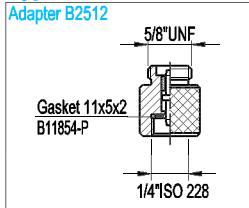
Type "B"

Adapter B2511



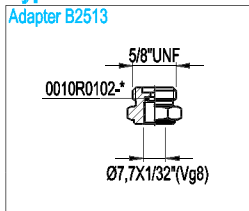
Type "C"

Adapter B2512



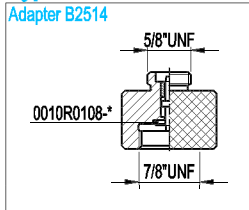
Type "D"

Adapter B2513



Type "E"

Adapter B2514



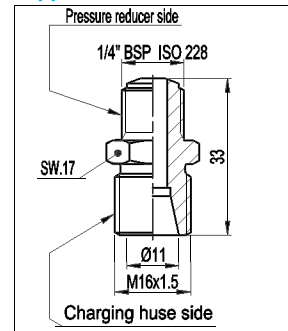
11.1e

Connection nipple for pressure reducer

The use of pre-charging equipment for the inflation of "low pressure" accumulators requires, for safety reasons, a pressure reducer (see Section 11.3) mounted on the nitrogen bottle, which is calibrated according to a pressure equal or lower than the maximum PS operating pressure, stamped on the accumulator shell.

The fitting nipple between the charging hose and the pressure reducer must be ordered separately with code 11447.

Nipple No. B2515



for pressure reducer see
chapter 11.3

11.1f

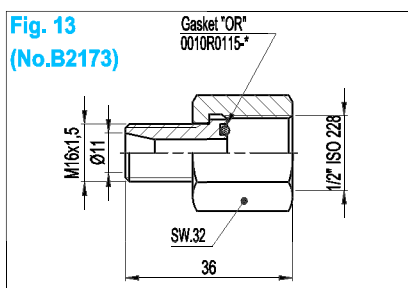
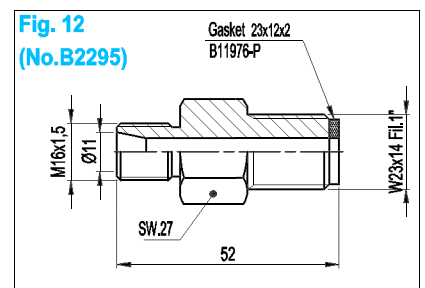
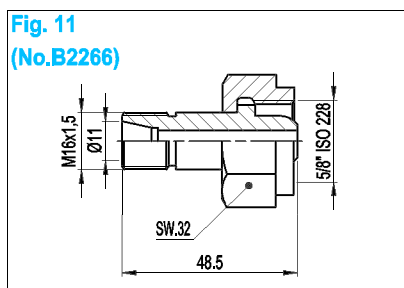
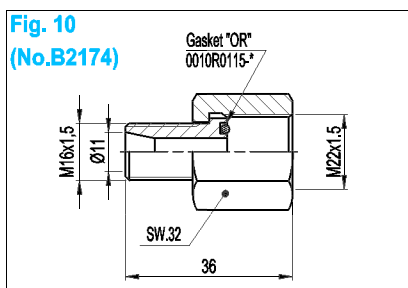
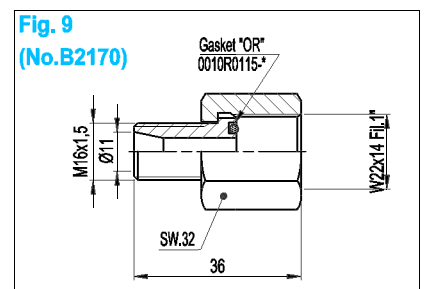
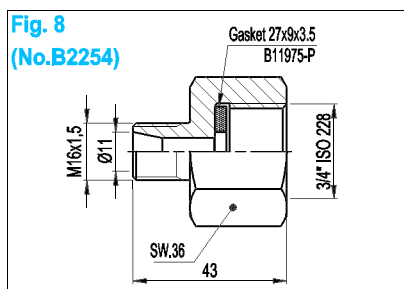
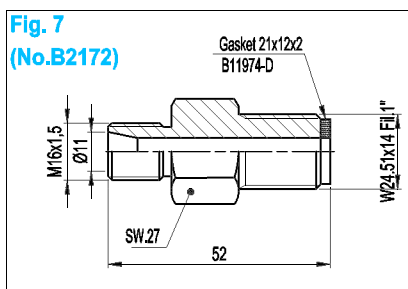
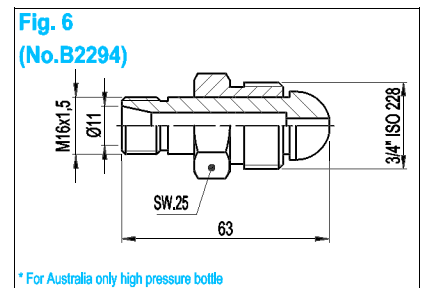
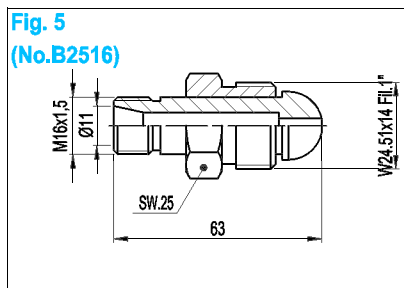
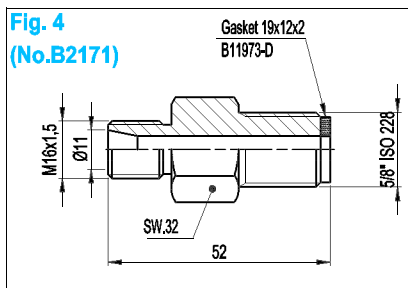
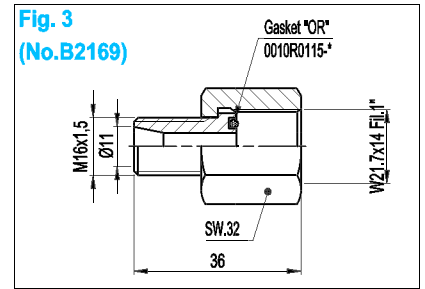
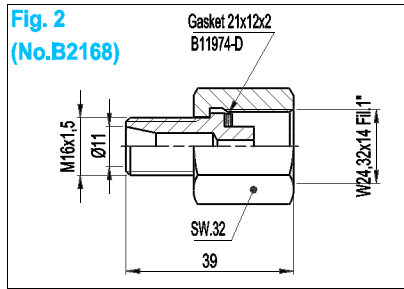
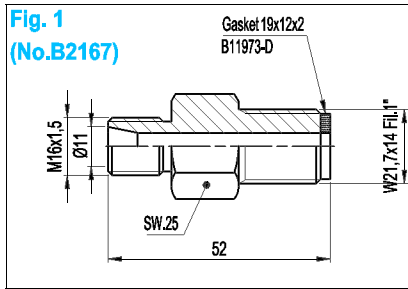
Connection nipple for nitrogen cylinder

For "high pressure" accumulators and for all models with PS ≥ 210 bar, you can connect to the nitrogen bottle through the proper fitting without the use of the pressure reducer.

The suitable nipple must be chosen according to the Country of origin of the nitrogen bottle, as shown in the side Table.

The no. of the column marked by the x indicates the figure of the nipple valid for that Country and coincides with the number used to indicate the bottle connection in the designation code of the complete equipment (Chapter 11.1.4).

Each nipple has its own code (in brackets) to be used for ordering spare parts and not indicated in the designation of the pre-charging equipment.



Country	Type / part code												
	1	2	3	4	5	6	7	8	9	10	11	12	13
Albania								X					
Algeria			X										
Argentina				X									
Australia						X							
Austria		X											
Bahamas				X									
Bahrain			X										
Barbados				X									
Belgium			X										
Bolivia													X
Brazil					X								
Bulgaria			X	X									
Canada							X						
Chile													X
China											X		
Colombia													X
Costa Rica				X									
Cyprus				X									
Czech Republic		X											
Denmark		X											
Dominican Republic													X
Ecuador													X
Egypt			X										
Ethiopia				X									
Finland		X											
France			X										
Gabon			X										
Gambia				X									
Germany		X											
Ghana				X									
Great Britain				X									
Greece				X									
Guatemala													X
Guinea			X										
Guyana													X
Honduras													X
Hong Kong				X									
Hungary			X										
India				X									
Indonesia				X									
Iran			X										
Iraq			X										
Ireland				X									
Israel			X										
Italy	X												
Ivory Coast			X										
Jamaica				X									
Japan									X				

Country	Type / part code												
	1	2	3	4	5	6	7	8	9	10	11	12	13
Jordan			X										
Kenya				X									
Korea												X	
Kuwait			X										
Libya			X										
Malaysia				X									
Malta				X									
Mauritius			X										
Mexico			X										
Morocco			X										
Mozambique			X										
Netherlands		X											
New Zealand				X									
Nigeria			X										
Norway		X											
Oman			X										
Pakistan				X									
Paraguay													X
Perù													X
Philippines						X							
Poland		X											
Portugal				X									
Puerto Rico					X								
Qatar			X										
Romania			X										
Russia								X					
Saudi Arabia			X										
Singapore				X									
Slovenia			X										
South Africa						X							
Spain			X										
Sri Lanka				X									
Sudan				X									
Sweden		X											
Switzerland		X											
Syria			X										
Taiwan										X			
Tanzania				X									
Thailand				X									
Tunisia			X										
Turkey				X									
United Arab Emirates			X										
Uruguay													X
U.S.A.							X						
Venezuela								X					
Vietnam				X									
Zambia				X									

11.1.9 COMMISSIONING AND MAINTENANCE

General

For proper operation of the accumulator, it is necessary to maintain a constant pre-charge pressure, which should be checked periodically using the pre-charge and checking set type PC250.

The same equipment is also used to inflate the accumulator (after a repair, for a change of use, etc.) connecting it with the appropriate charging hose to a dry nitrogen bottle equipped with pressure reducer (see Section 11.3), so that the nitrogen enters the accumulator very slowly to avoid possible breakage of the bladder or the diaphragm and to limit the temperature change.

In fact, the process of charging or discharging an accumulator with nitrogen causes a temperature change which is transmitted to the surrounding air until the temperature of the accumulator stabilizes.

For the effects of temperature transfer, the accumulator should be allowed to stand for a minimum of 60 minutes before a final reading of the pre-charge pressure is taken.

Checking the pre-charge

Before proceeding, it is necessary to isolate the accumulator from the system and discharge completely the fluid under pressure.

Remove the cap of the gas valve and the cap of the filling valve.

Before mounting the PC250 equipment, make sure that the knob A is unscrewed, that the bleed B is closed, that the check valve C has its cap screwed and that the pressure gauge has mounted a full scale appropriate to the pressure to read (normally the pressure to be read must not exceed the 3/4 of full scale).

Tighten by hand, using the knurled nut D, the charging set on the gas valve.

Screw, without forcing, the knob A to read the pressure on the gauge.

If the value corresponds to the one required, you can proceed to unscrew the knob A until it stops, but without forcing, open the bleed B and disassemble the equipment by unscrewing the nut D.

Decreasing the pre-charge

If the pre-charge value is greater than the one required, you should discharge the exceeding pressure by acting on the bleed B until reaching the desired value.

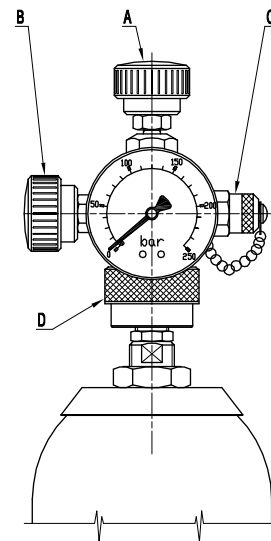
We suggest **discharging slowly** and then carrying out the final reading after at least 15 minutes from the discharge operation. Then you can remove the equipment as above indicated.

Increasing or restoring the pre-charge

If the pre-charge is less than the established value (or if it is necessary to re-inflate the accumulator after a repair), proceed as follows (place the equipment as indicated in the Section "Checking the pre-charge"):

- Mount the nipple to the nitrogen bottle or to the pressure reducer.
- Connect the hose extremity to the nipple.
- Connect the other hose extremity to the check valve C after having removed its cap.
- Open slowly the shut-off valve of the nitrogen bottle or the knob of the pressure reducer and keep it open until it reaches a pressure slightly higher than the required value (+ 10 ÷ 15%), then close the valve.
- Unscrew the knob A and decompress the equipment with the bleed valve B.
- Disconnect the charging hose of the check valve C.
- Close the bleed valve, place the cap to the check valve C and wait at least 15 minutes for the pressure stabilization.
- Screw again the knob A until reading the pressure that should be slightly higher than requested. Adjust the pre-charge value, using the bleed valve, and disassemble the equipment, as already indicated.
- Check with soapy water that there are no leaks coming out from the filling valve of the accumulator.
- Screw the cap of the filling valve and the external protection cap.

Now the accumulator is ready for commissioning.



11.1i

Reproduction is forbidden.

In the spirit of continuous improvement, our products may be changed.

11.2.1 TECHNICAL DATA

MAX OPERATING PRESSURE (PS): 400 BAR

PRESSURE TEST (PT): 1.43 x PS

SCALE OF PRESSURE GAUGE:

4 - 10 - 16 - 25 - 60 - 100 - 250 (std.) - 400 bar

WORKING TEMPERATURE: - 20 ÷ +80°C

MEDIUM: Nitrogen

NITROGEN CONTAMINATION DEGREE:

class 20/18/15 according to ISO 4406/99

BODY MATERIAL: phosphated carbon steel or galvanized carbon steel in compliance with Directive 2002/95/EC (RoHS) to resist to corrosion

SEALS MATERIAL: P = Nitrile rubber (NBR) and Delrin

FILLING VALVE CONNECTION: M28x1.5 + adapters (upon request)

WEIGHT: 1.8 Kg. (complete with case)

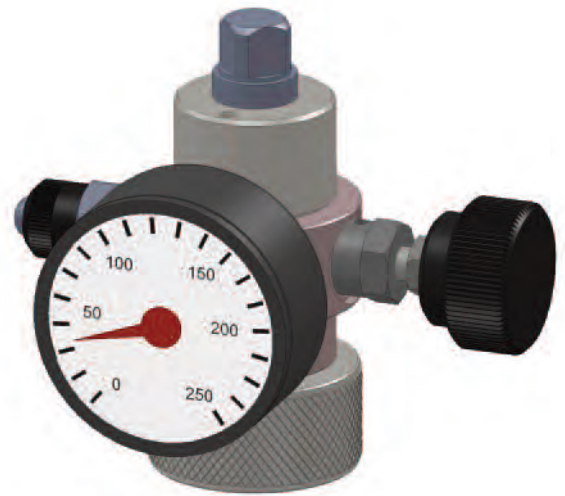
11.2.2 DESCRIPTION

The charging and gauging assembly consists of 3 mt. charging hose with standard nitrogen nipples, body incorporating gas valve connection, bleed valve and check valve. These kits are packed in a plastic storage case. Gauge is diameter 63 mm. diam. type pressure gauges with 0÷250 bar graduation. The following are recommended for use on all piston accumulators (with standard filling valve type VM) and on all welded diaphragm accumulators.

It is used for the periodic check of accumulator pre-charge and for the inflation of accumulators after the maintenance or it is used for the change of pre-charge value. For the inflation, it is necessary a connection to a bottle filled with industrial dry nitrogen with a pressure higher than the pre-charge value required, provided with pressure reducer (mandatory, for safety reasons, during the inflation of accumulators with PS < 210 bar).

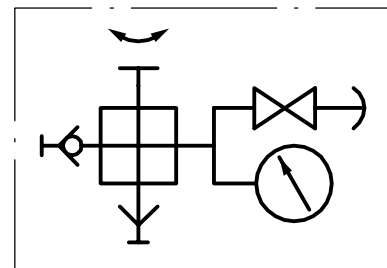
Furthermore, the use of a pressure reducer makes easier the slow and graduated inflow of nitrogen on the bladder, thus avoiding the possibility of damaging the bladder itself.

NOTE: These assemblies are not recommended for continuous monitoring of gas pre-charge. For continuous monitoring, see Gas Adapters at Section 8.3



11.2a

11.2.3 HYDRAULIC SYMBOL



11.2b

11.2.4 CONSTRUCTION

STANDARD VERSION includes:

- Valve body complete of ring nut connection to accumulator gas valve, pressure gauge, bleed and non return snap-in hose connection.
- 3 mt charging hose for high pressure series complete with bottle connection.
- Set of spare gaskets.
- Case.

UPON REQUEST:

- Nipple for pressure reducer.
- ADAPTERS for special accumulator gas valves.
- CHARGING HOSE with length of 1 - 4 - 6 mt.

11.2.5 ORDER CODE

1	2	3	4	5
PCM	250	M	1	- -

1	Series
	Pre-loading and checking = PCM

2	Scale of pressure gauge (bar)
	0 ÷ 4 = 4
	0 ÷ 10 = 10
	0 ÷ 16 = 16
	0 ÷ 25 = 25
	0 ÷ 60 = 60
	0 ÷ 100 = 100
	0 ÷ 250 = 250 (standard)
	0 ÷ 400 = 400

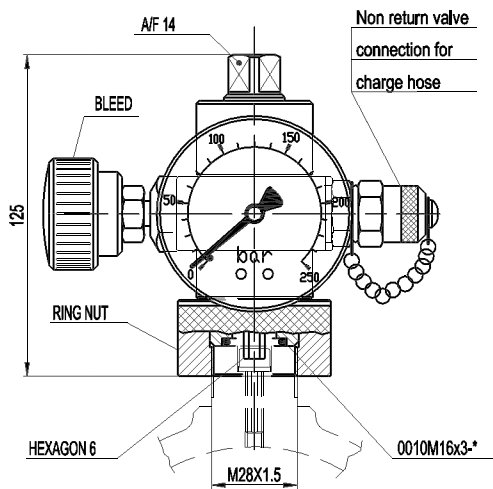
3	Filling valve connection
	M28x1.5 = M (standard)
	3/4 BSP ISO 228 = R
	5/8" UNF = S
	VG8 (Ø 7.7 x 1/32") = A
	7/8" UNF = B
	1/4" BSP ISO 228 = C
	VG8 (Ø 7.7 x 1/32") = D
	long thread = D
	7/8" UNF with pin = E

5	Charging hose (meters)
	Standard 3 mt = -
	1 mt = C
	4 mt = M
	6 mt = L

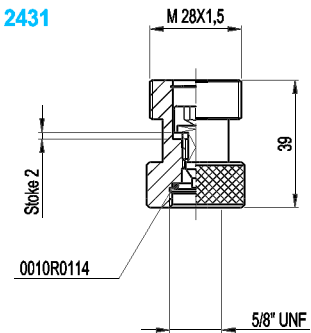
4		Connection to bottle (according to Country standards)
Italy	= 1	Indonesia
Austria	= 2	Ireland
Czech Republic		Jamaica
Denmark		Kenya
Finland		Malaysia
Germany		Malta
Netherlands		New Zealand
Norway		Pakistan
Poland		Portugal
Sweden		Singapore
Switzerland		Sri Lanka
Belgium	= 3	Sudan
Algeria		Tanzania
Bahrain		Thailand
Bulgaria		Turkey
Egypt		Vietnam
France		Zambia
Gabon		Brazil = 5
Guinea		Puerto Rico
Hungary		South Africa = 6
Iran		Philippines
Iraq		Canada = 7
Israel		U.S.A.
Ivory Coast		Albania = 8
Jordan		Russia
Kuwait		Venezuela
Libya		Japan = 9
Mauritius		Taiwan = 10
Mexico		China = 11
Morocco		Korea = 12
Mozambique		Bolivia = 13
Nigeria		Chile
Oman		Colombia
Qatar		Dominican Republic
Romania		Ecuador
Saudi Arabia		Guatemala
Slovenia		Guyana
Spain		Honduras
Syria		Paraguay
Tunisia		Peru
United Arab Emirates		Uruguay
Argentina	= 4	
Bahamas		
Barbados		
Costa Rica		
Cyprus		
Ethiopia		
Gambia		
Ghana		
Great Britain		
Greece		
Hong Kong		
India		

Special variants on request

11.2.6 DIMENSIONS



Adapter. 2431



11.2c

11.2.7 SPARE PARTS CODE

Spare parts	number code
Complete PCM body	B2154/*
PCM body without manometer	B2155
Manometer	B2163/*
Flexible hose of 1 meter	B2166/1
Flexible hose of 3 meters (standard)	B2166/3
Flexible hose of 4 meter	B2166/4
Flexible hose of 6 meter	B2166/6
Central pin (key)	B10850-C
Complete bleed	B2164
Non return valve	B2162
Seals kit	B2161/**
Seal face for filling valve	0010M16x3-P

* = see scale of pressure gauge at Section 11.2.5

11.2d

** = see table 11.2h for country codes

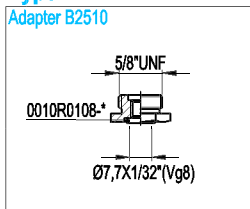
11.2.8 ACCESSORIES

Adapters

All adapters represented below serve to use the EPE pre-charge equipment on the accumulators of the main international manufacturers.

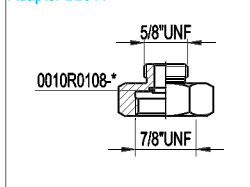
Type "A"

Adapter B2510



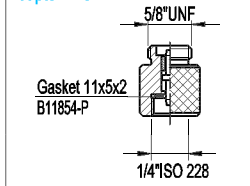
Type "B"

Adapter B2511



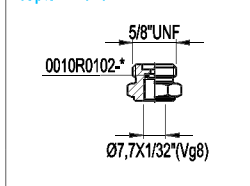
Type "C"

Adapter B2512



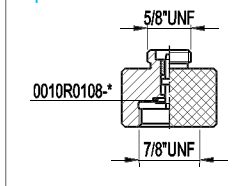
Type "D"

Adapter B2513



Type "E"

Adapter B2514



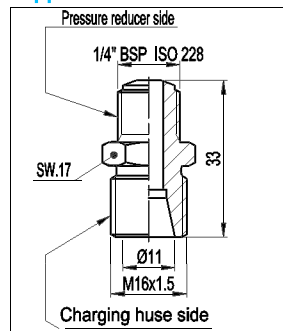
11.2e

Connection nipple for pressure reducer

The use of pre-charging equipment for the inflation of "low pressure" accumulators requires, for safety reasons, a pressure reducer (see Section 11.3) mounted on the nitrogen bottle, which is calibrated according to a pressure equal or lower than the maximum PS operating pressure, stamped on the accumulator shell.

The nipple between the charging hose and the pressure reducer must be ordered separately with code 11447.

Nipple No. B2515



for pressure reducer see
chapter 11.3

11.2f

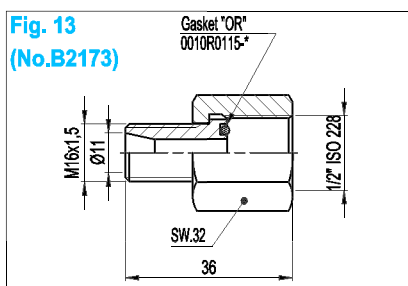
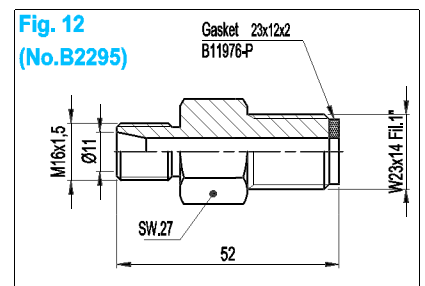
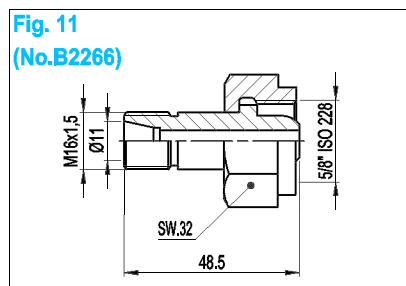
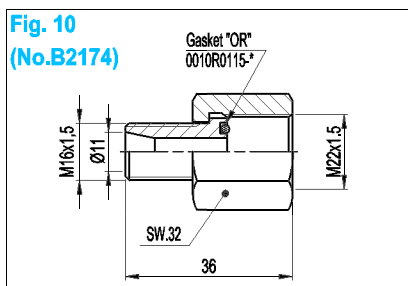
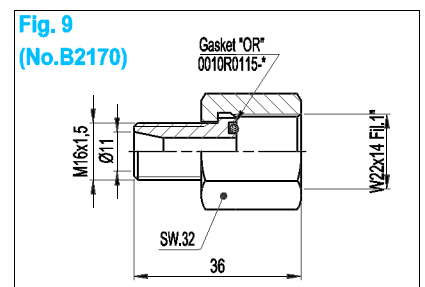
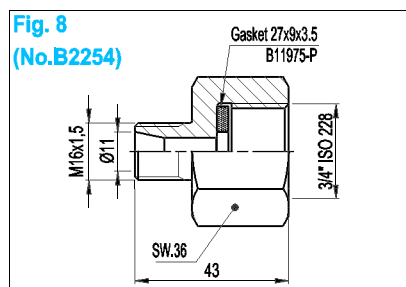
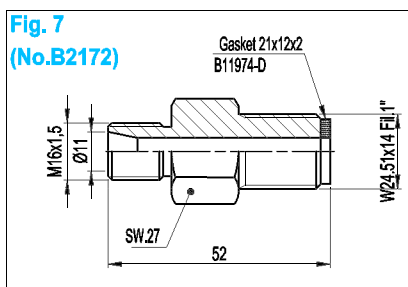
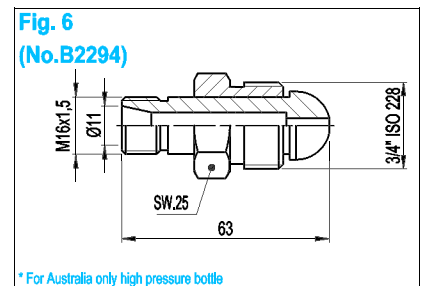
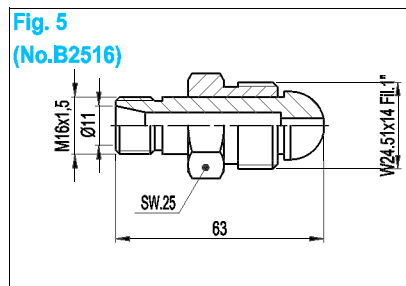
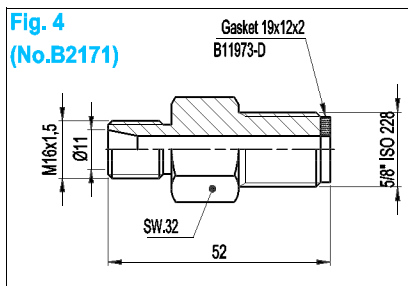
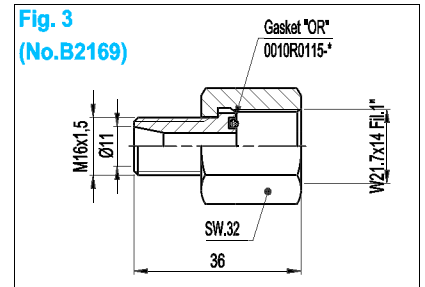
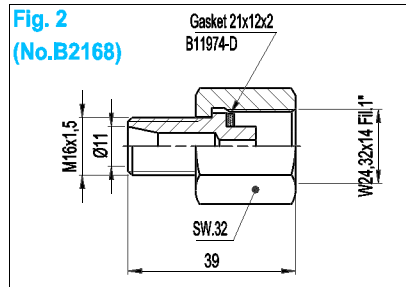
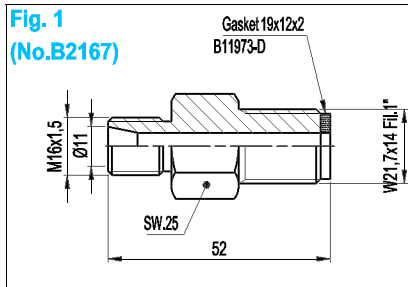
Connection nipple for nitrogen cylinder

For "high pressure" accumulators and for all models with PS ≥ 210 bar, you can connect to the nitrogen bottle through the proper nipple without the use of the pressure reducer.

The suitable nipple must be chosen according to the Country of origin of the nitrogen bottle, as shown in the side Table.

The no. of the column marked by the x indicates the figure of the nipple valid for that Country and coincides with the number used to indicate the bottle connection in the designation code of the complete equipment (Chapter 11.1.4).

Each nipple has its own code (in brackets) to be used for ordering spare parts and not indicated in the designation of the pre-charging equipment.



Country	Type / part code												
	1	2	3	4	5	6	7	8	9	10	11	12	13
Albania								X					
Algeria			X										
Argentina				X									
Australia						X							
Austria		X											
Bahamas				X									
Bahrain			X										
Barbados				X									
Belgium			X										
Bolivia													X
Brazil					X								
Bulgaria			X	X									
Canada							X						
Chile													X
China											X		
Colombia													X
Costa Rica				X									
Cyprus				X									
Czech Republic		X											
Denmark		X											
Dominican Republic													X
Ecuador													X
Egypt			X										
Ethiopia				X									
Finland		X											
France			X										
Gabon			X										
Gambia				X									
Germany		X											
Ghana				X									
Great Britain				X									
Greece				X									
Guatemala													X
Guinea			X										
Guyana													X
Honduras													X
Hong Kong				X									
Hungary			X										
India				X									
Indonesia				X									
Iran			X										
Iraq			X										
Ireland				X									
Israel			X										
Italy	X												
Ivory Coast			X										
Jamaica				X									
Japan									X				

Country	Type / part code												
	1	2	3	4	5	6	7	8	9	10	11	12	13
Jordan			X										
Kenya				X									
Korea												X	
Kuwait			X										
Libya			X										
Malaysia				X									
Malta				X									
Mauritius			X										
Mexico			X										
Morocco			X										
Mozambique			X										
Netherlands		X											
New Zealand				X									
Nigeria			X										
Norway		X											
Oman			X										
Pakistan				X									
Paraguay													X
Perù													X
Philippines						X							
Poland		X											
Portugal				X									
Puerto Rico					X								
Qatar			X										
Romania			X										
Russia								X					
Saudi Arabia			X										
Singapore				X									
Slovenia			X										
South Africa						X							
Spain			X										
Sri Lanka				X									
Sudan				X									
Sweden		X											
Switzerland		X											
Syria			X										
Taiwan										X			
Tanzania				X									
Thailand				X									
Tunisia			X										
Turkey				X									
United Arab Emirates			X										
Uruguay													X
U.S.A.							X						
Venezuela								X					
Vietnam				X									
Zambia				X									

11.2.9 COMMISSIONING AND MAINTENANCE

General

For proper operation of the accumulator, it is necessary to maintain a constant pre-charge pressure, which should be checked periodically using the pre-charge and checking set type PC250.

The same equipment is also used to inflate the accumulator (after a repair, for a change of use, etc.) connecting it with the appropriate charging hose to a dry nitrogen bottle equipped with pressure reducer (see Section 11.3), so that the nitrogen enters the accumulator very slowly to avoid possible breakage of the bladder or the diaphragm and to limit the temperature change.

In fact, the process of charging or discharging an accumulator with nitrogen causes a temperature change which is transmitted to the surrounding air until the temperature of the accumulator stabilizes.

For the effects of temperature transfer, the accumulator should be allowed to stand for a minimum of 60 minutes before a final reading of the pre-charge pressure is taken.

Checking the pre-charge

Before proceeding, it is necessary to isolate the accumulator from the system and discharge completely the fluid under pressure.

Remove the cap of the gas and the cap of the filling valve.

Before mounting the PCM equipment, make sure that the knob A is unscrewed, that the bleed B is closed, that the check valve C has its cap screwed and that the pressure gauge has mounted a full scale appropriate to the pressure to read (normally the pressure to be read must not exceed the 3/4 of full scale).

Tighten by hand, using the knurled nut D, the charging set on the gas valve.

Screw, without forcing, the knob A to read the pressure on the gauge.

If the value corresponds to the one required, you can proceed to unscrew the knob A until it stops, but without forcing, open the bleed B and disassemble the equipment by unscrewing the nut D.

Decreasing the pre-charge

If the pre-charge value is greater than the one required, you should discharge the exceeding pressure by acting on the bleed B until reaching the desired value.

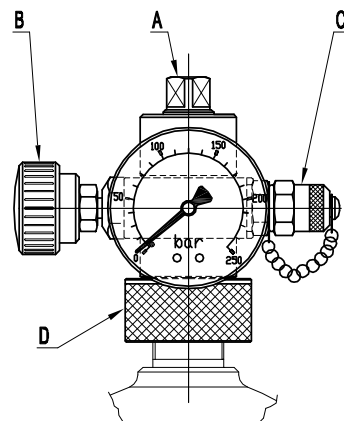
We suggest **discharging slowly** and then carrying out the final reading after at least 15 minutes from the discharge operation. Then you can remove the equipment as above indicated.

Increasing or restoring the pre-charge

If the pre-charge is less than the established value (or if it is necessary to re-inflate the accumulator after a repair), proceed as follows (place the equipment as indicated in the Section "Checking the pre-charge"):

- Mount the nipple to the nitrogen bottle or to the pressure reducer.
- Connect the hose extremity to the nipple.
- Connect the other hose extremity to the check valve C after having removed its cap.
- Open slowly the shut-off valve of the nitrogen bottle or the knob of the pressure reducer and keep it open until it reaches a pressure slightly higher than the required value (+ 10 ÷ 15%), then close the valve.
- Unscrew the knob A and decompress the equipment with the bleed valve B.
- Disconnect the charging hose of the check valve C.
- Close the bleed valve, place the cap to the check valve C and wait at least 15 minutes for the pressure stabilization.
- Screw again the knob A until reading the pressure that should be slightly higher than requested. Adjust the pre-charge value, using the bleed valve, and disassemble the equipment, as already indicated.
- Check with soapy water that there are no leaks coming out from the filling valve of the accumulator.
- Screw the cap of the filling valve and the external protection cap.

Now the accumulator is ready for commissioning.



11.2i

Reproduction is forbidden.

In the spirit of continuous improvement, our products may be changed.

11.3.1 TECHNICAL DATA

MAX OPERATING PRESSURE (PS): 220 bar

PRESSURE TEST (PT): 1.43 x PS

WORKING TEMPERATURE: - 20 ÷ +60°C

MEDIUM: Nitrogen

NITROGEN CONTAMINATION DEGREE:
class 20/18/15 according to ISO 4406/99

MATERIAL BODY AND INTERNAL PARTS: brass

DIAPHRAGM: stainless steel

PLATING: chromium plating

SEALS MATERIAL: P = Nitrile RUBBER (NBR) and Delrin

PORT CONNECTIONS: M16x1.5 tube dia. 8

WEIGHT: 1,75 Kg.

11.3.2 DESCRIPTION

The pressure reducer it is used for adjusting the required pre-charge pressure between the nitrogen bottle and the accumulator.

For safety reasons the user it is obliged, when using nitrogen gas bottles, to install a nitrogen reducer.

This nitrogen reducer enables you to reduce the pressure, available from the gas bottle, to the pressure required.

Also with the big hand kinds on the reducer it is easier to adjust the flow of the gas. By using this reducer you eliminate the possibility to over-charge an accumulator which has a lower working pressure than the gas pressure stored on the nitrogen bottle.

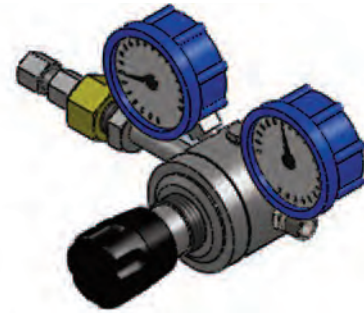
The reducer is easy to adjust to the required gas pressure.

Also the connections fit directly to the gas bottle (using the nipple 11447) and the charging hose of the EPE pre-loading set.

The reducer has a heavy duty construction and it is suitable for nitrogen gas bottles, 200 bar max.

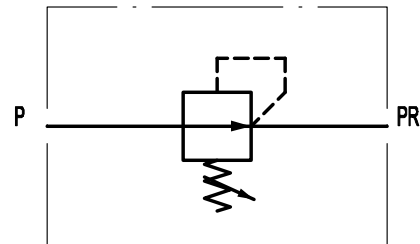
Standard version includes:

- 2 pressure gauges, indicating pressure of gas bottle and reduced pressure out. Pressure range is 0-300 bar.
- Reduction pressure is adjustable from 0 to 200 bar.



11.3a

11.3.3 HYDRAULIC SYMBOL



11.3b

11.3.4 MOUNTING

During the setting up operations, all components in contact with gas must be free of grease and oil.

Follow scrupulously the instructions either before then during the operations. Before installation check that the pressure regulator is suitable to work with the specific gas.

Check that the connections are clean and not damaged, otherwise the reducer has not to be installed. Before connection of the regulator, open and close completely the valve of the bottle to remove any possible impurity.

Never stay and put your hand in front of the bottle valve.

Tighten the nut or the hanger (1 - 7) to connect the pressure of the bottle valve.

The regulator has to be placed as showed in drawing 11.3C and the adjusting screw have to be unloosen turning it anticlockwise.

Connect the regulator to the system by the outlet fitting. Open slowly the valve of the bottle and the inlet gauge will show the bottle pressure.

Adjust the outlet pressure on the gauge turning clockwise the adjusting screw.

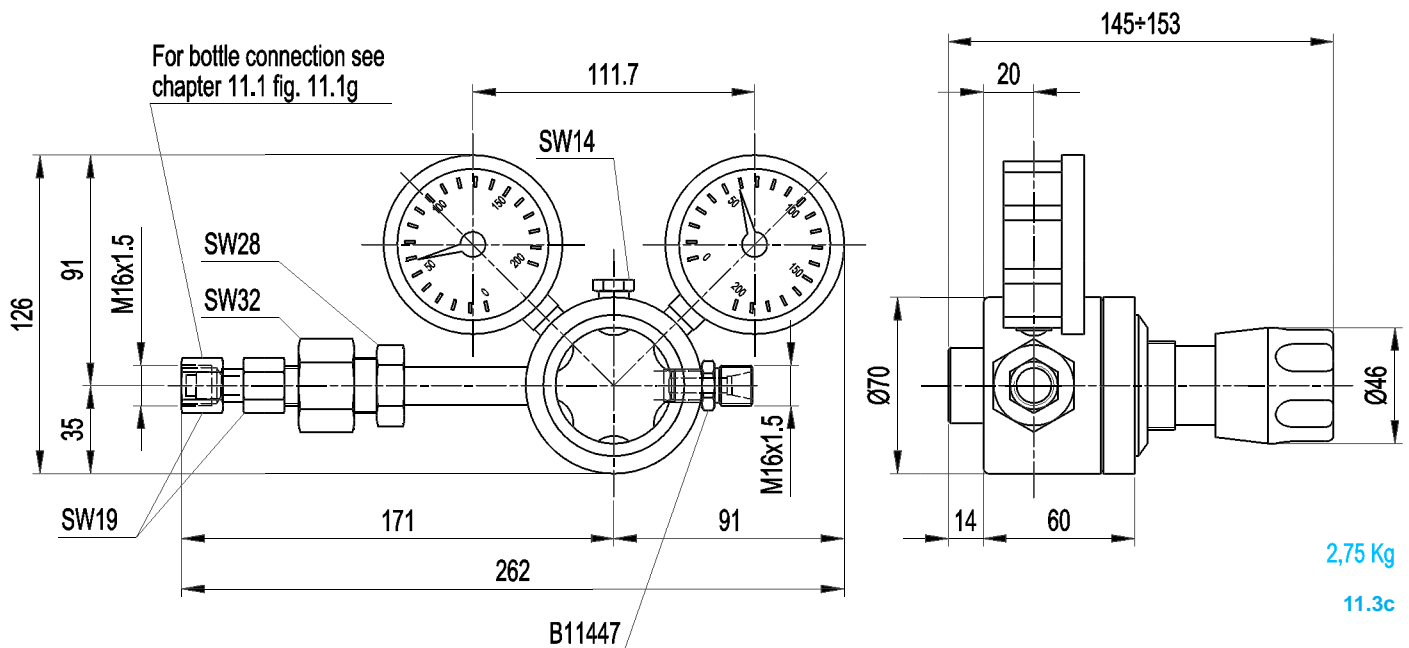
11.3.5 ORDER CODE

B2494	/	8
-------	---	---

Scale of pressure gauge (bar)	
Outlet pressure:	
1 ÷ 8 bar	8
1,5 ÷ 15 bar	15
3 ÷ 30 bar	30
5 ÷ 50 bar	50
10 ÷ 100 bar	100
30 ÷ 200 bar	200

Special variants on request

11.3.6 DIMENSIONS



Model	Inlet max pressure bar	Outlet pressure bar	Max flow Nm ³ /h	Regulation system	Gauges IN bar	Gauges OUT bar
B2494/8	220	1 ÷ 8	30	Diaphragm	0 ÷ 315	0 ÷ 16
B2494/15	220	1,5 ÷ 15	45	Diaphragm	0 ÷ 315	0 ÷ 25
B2494/30	220	3 ÷ 30	60	Piston	0 ÷ 315	0 ÷ 63
B2494/50	220	5 ÷ 50	60	Piston	0 ÷ 315	0 ÷ 100
B2494/100	220	10 ÷ 100	60	Piston	0 ÷ 315	0 ÷ 160
B2494/200	220	30 ÷ 200	60	Piston	0 ÷ 315	0 ÷ 315

11.3d

11.3.7 INSTRUCTIONS

Avoid that the reducer could be damaged (by duly visual check). Don't change calibration of the over-pressure valve. Keep gasket and gauges in perfect conditions.

In case of bad working of the pressure reducer (e.g. raising of outlet pressure without consumption, gauges and safety valve's leakage) lock immediately the flow to the reducer closing of the bottle valve.

11.3.8 REPAIRING

The pressure reducer must be repaired only by skilled personnel or in our factory. Original spare parts are compulsory for EPE ITALIANA guarantee.

EPE ITALIANA will not respond for arbitrary repair or changing made by users or other persons without its previous autorisation.

Reproduction is forbidden.

In the spirit of continuous improvement, our products may be changed.

11.4.1 TECHNICAL DATA

- MAX OPERATING PRESSURE (PS) of oil: 350 bar
- MAX OPERATING PRESSURE (PS) of nitrogen: 350 bar
- PRESSURE TEST (PT): 1.43 x PS
- MIN. SUPPLY PRESSURE NITROGEN: 5 bar
- WORKING TEMPERATURE: -20 ÷ +80 °C
- MEDIUM: Nitrogen
- PRESSURE GAUGE RANGE: 0 ÷ 400 bar
- FLOW RATE OF THE HYDRAULIC PUMP: 9 l/min
- CAPACITY OIL TANK: 70 l
- SIDE CONNECTION BOTTLE: W 21.7 X 14 (Other upon request)
- ACCUMULATOR SIDE CONNECTION: 5/8" UNF (Other upon request)
- HOSE LENGTH: 6 mt.
- THREE-PHASE MOTOR: 380 V - 50Hz
- MAX. P.: 5.5 Kw
- SAFETY TYPE: IP 55
- ELECTRICAL CONNECTION: CEE plug, 5-pole, 16 Amp 400V
- CABLE LENGTH: 10 mt.
- WEIGHT: Kg. 280

11.4.2 DESCRIPTION

Nitrogen preloading carts are useful in many circumstances and have many advantages compared to simple gas bottle, which are usually loaded at 200 bar. Different models of carts can operate to enhance pressure and flow of standard gas bottles, or to directly generate nitrogen for loading purpose or for storage.

Major advantages are:

- Use of the whole gas bottle content even when preloading pressure is higher than bottle pressure
- Faster loading when there is high preloading pressure or big accumulator volume
- Possibility to generate nitrogen directly from air avoiding any purchase of bottles

Other size on request



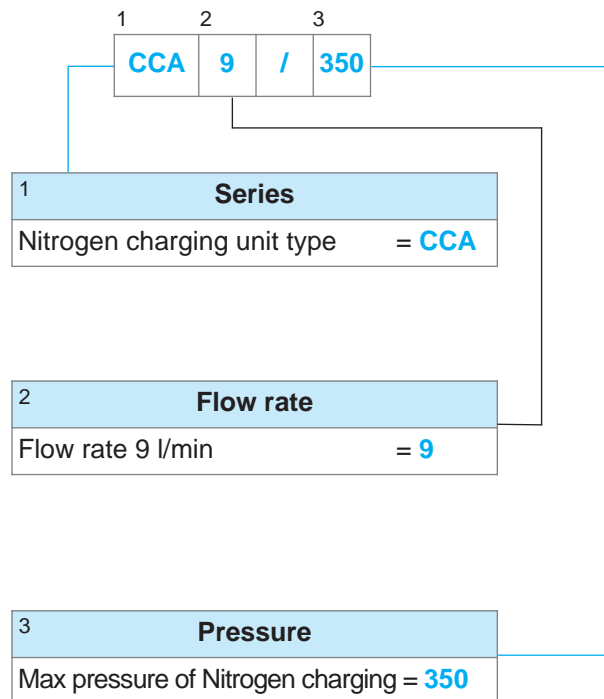
11.4a

11.4.3 ACCESSORIES

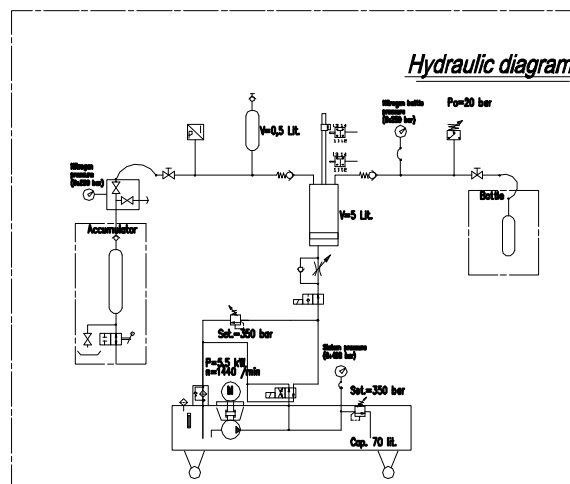
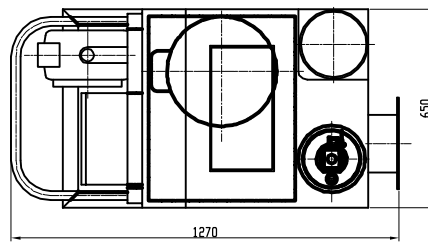
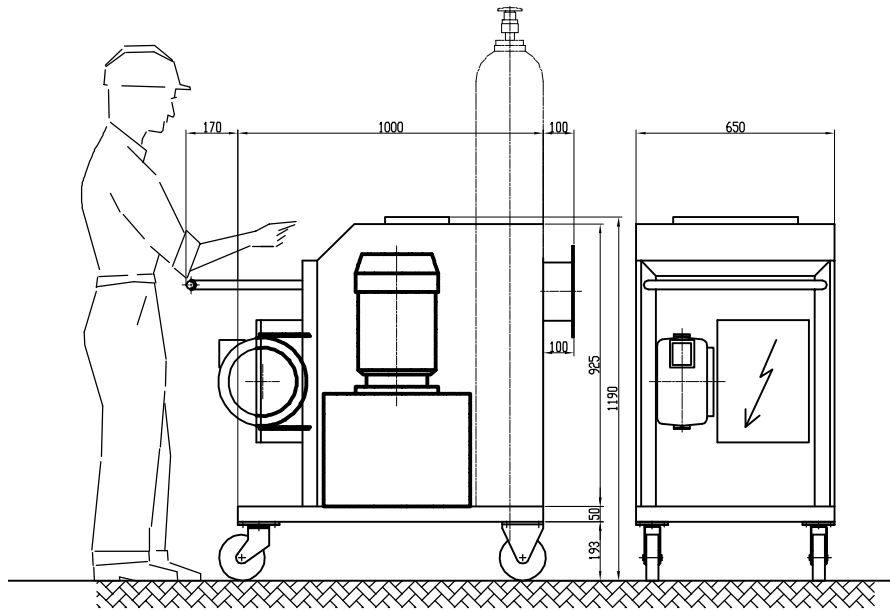
Alternatively, you can use, instead of pre-compressed nitrogen stored in bottles, a trolley which produces nitrogen from compressed air at 8 ÷ 10 bar.

For more information and / or requests, please contact our technical service.

11.4.4 ORDER CODE



11.4.5 DIMENSIONS AND HYDRAULIC DIAPHRAGM



11.4b

Reproduction Is Forbidden.
In The Spirit Of Continuous Improvement, Our Products May Be Changed.