

Servi Cyclone

Oversikt pr. 17.06.2014

SERVI
GROUP™

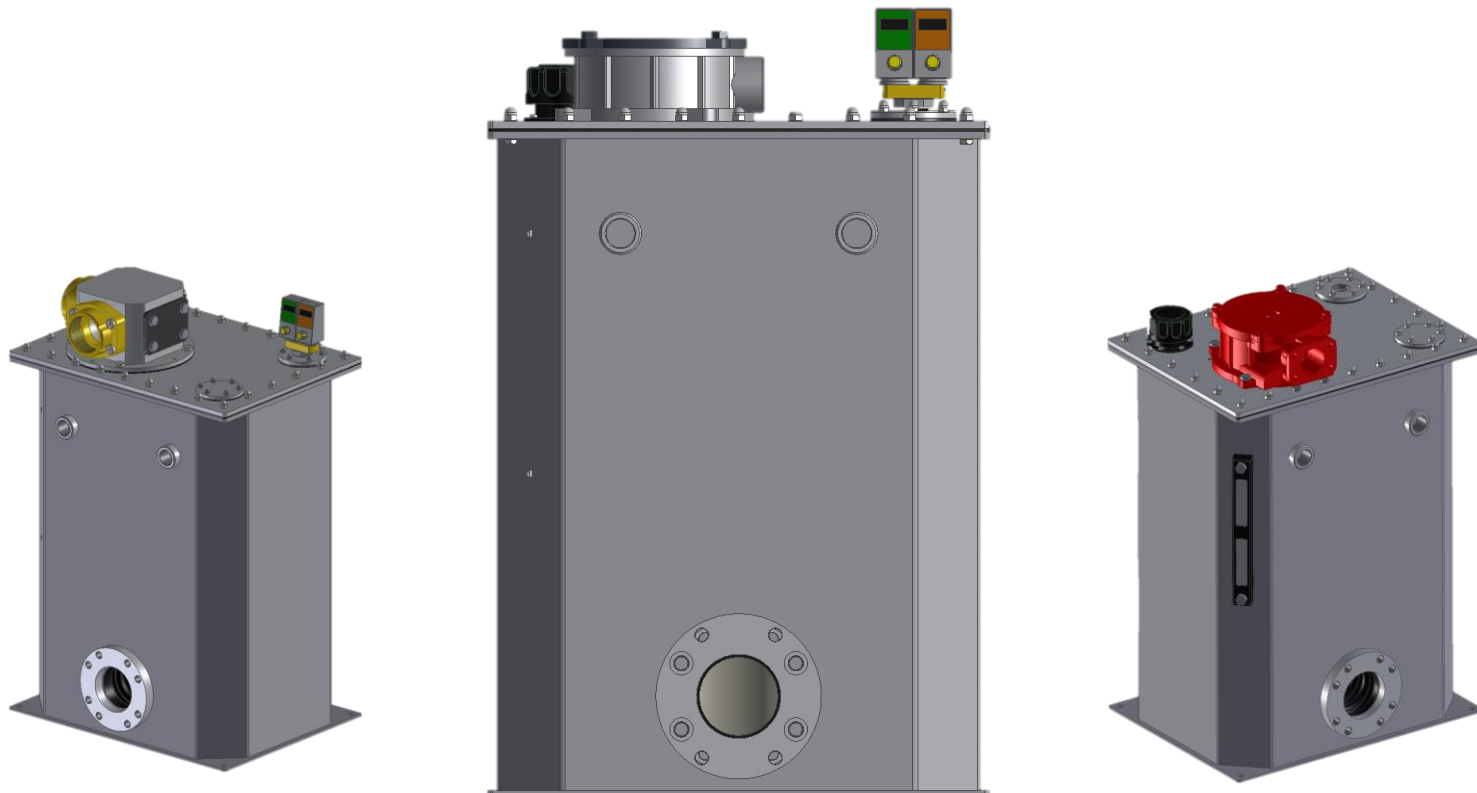

Servi Cyclone

SERVI
GROUP™

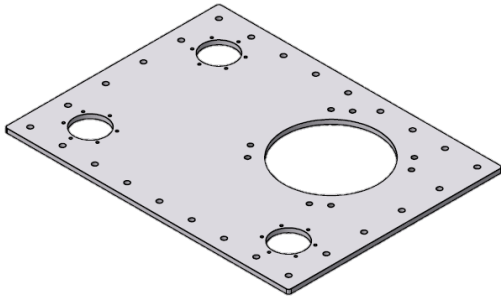

Lokk for cyclonetank 60/120 liter
Tegn. nr. 305-009-P02
Art.nr: 305009P02

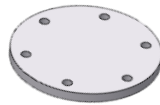

Blindlokk
Tegn. nr. 306-HP-004-10-P08
Art.nr: 306HP00410P08



Adapter for temp/nivåmåler
Tegn. nr. 305-HP-007-10-P07
Art.nr: 305HP00710P07

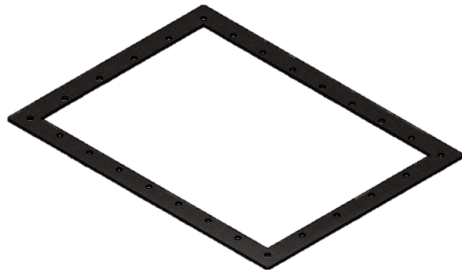

Pakning for topplate
Tegn. nr. 305-HP-007-10-P06
Art. nr. 305HP00710P06



Pakning for blindlokk
Tegn. nr. 306-HP-004-10-P09
Art. nr. 306HP00410P09

120 L tank

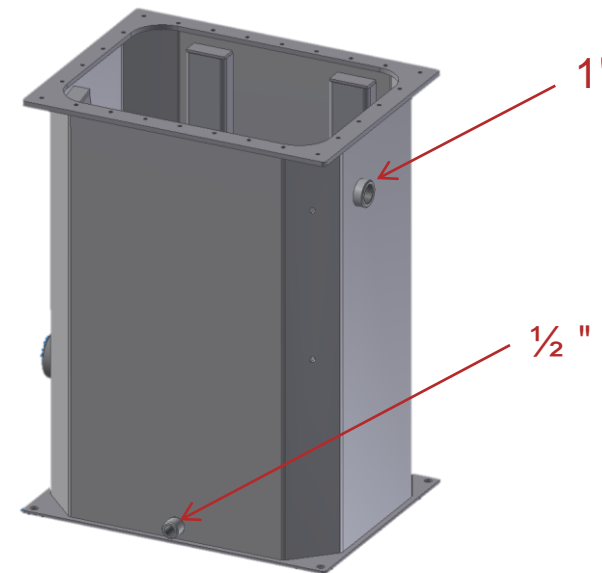
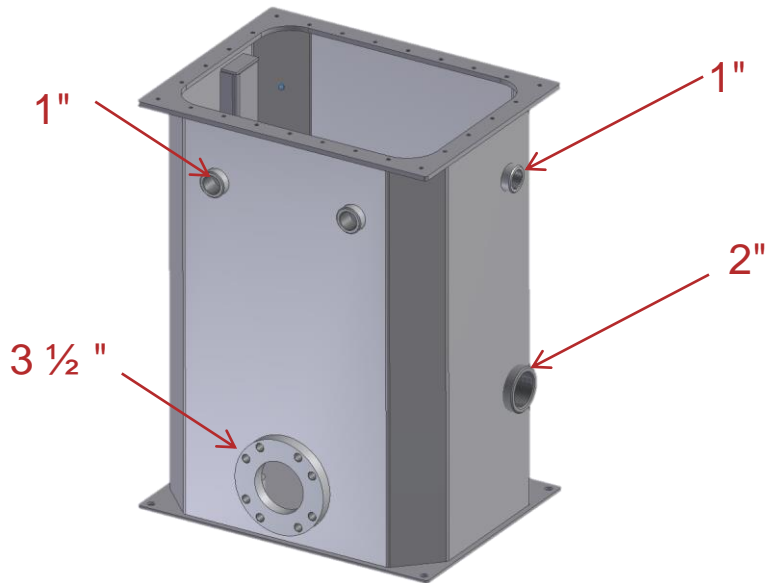

Art.nr.	Beskrivelse
305HP00710P33	3 1/2" til 1 1/2"
305007P34	3 1/2" til 2"
305HP00710P31	3 1/2" til 3"
305HP00710P32	3 1/2" til 4"
305035P05	3 1/2" til 2 1/2"



Art. nr. 305016A02

MPF 400/450-451

SERVI
GROUP™

Filter type MPF 400/450-451 lengde 3
Hylse for filter: tegn. nr. 305-011-P01

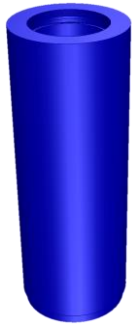
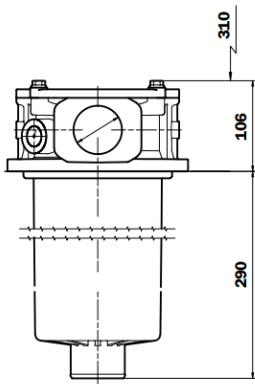

Art: 305011P01

Filter type MPF 400/450-451 lengde 2
Hylse for filter: tegn. nr. 305-011 P02

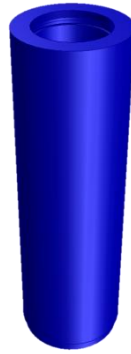
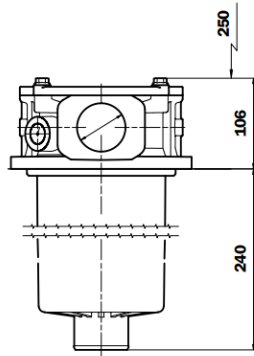

Art: 305011P02

Filter type MPF 400/450-451 lengde 1
Hylse for filter: tegn. nr. 305-011 P03

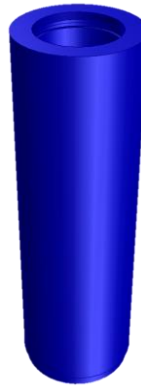
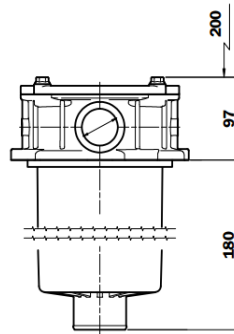

Art: 305011P03

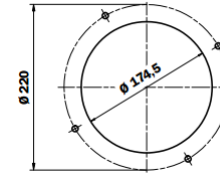

Cyclone innfestning.
Tegn. Nr. 305-HP-007-10-P29

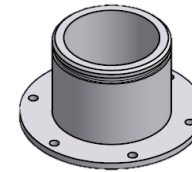

Art: 305HP00710P29

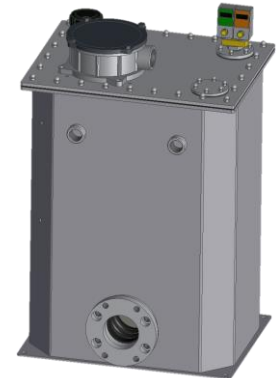
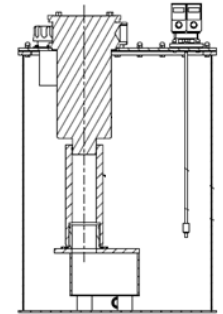

	Length	A03	A06	A10	A16	A25	P10	P25	M25	M60
MPF450	1	150	175	335	340	550	385	600	680	680
	2	230	250	440	455	660	550	690	750	750
	3	250	295	470	480	680	700	750	800	800

Recommended maximum flow rate
 - Pressure drop of filter assembly equal to Δp 0,5 bar.
 - Oil kinematic viscosity 30 mm²/s (cSt).
 - Density 0,86 kg/dm³

MPF 750



Filter type MPF 750
Hylse for filter: tegn. nr. 305-010-P01

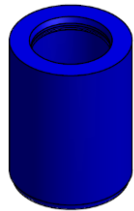
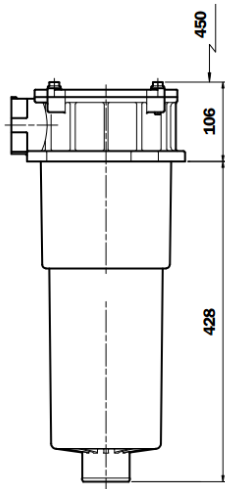

Cyclone inffestning.
Tegn. Nr. 305-HP-007-10-P29

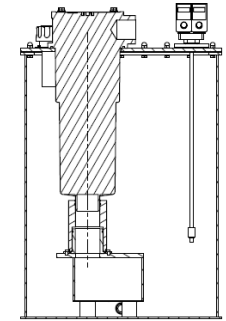
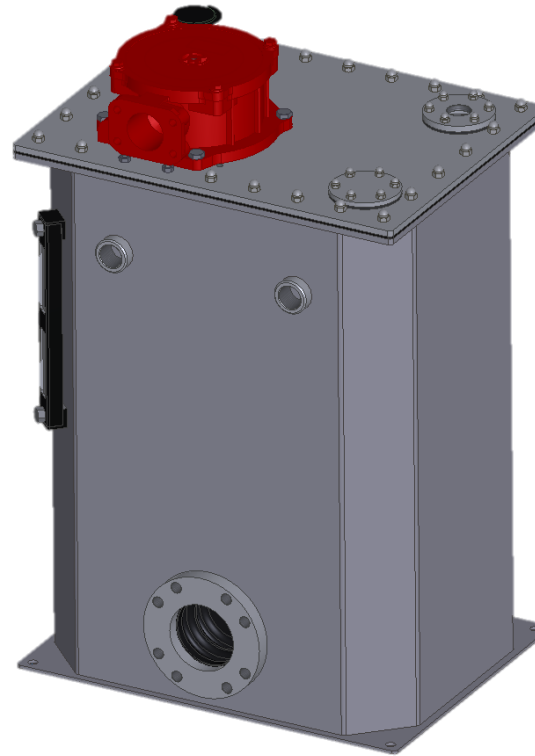
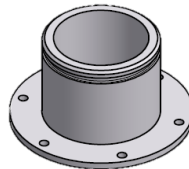
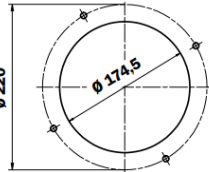

Komplett tank m/filter
Art.nr: 305010A05
Tegn. nr. 305-010-A05

Art: 305010P01

Art: 305HP00710P29

	Length	A03	A06	A10	A16	A25	P10	P25	M25	M60
MPF750	1	390	450	625	700	780	700	750	900	900

Recommended maximum flow rate
 - Pressure drop of filter assembly equal to Δp 0,5 bar.
 - Oil kinematic viscosity 30 mm²/s (cSt).
 - Density 0,86 kg/dm³

MPF 750 Rev-2



Filter type MPF 750
Hylse for filter: tegn. nr. 305-016-P02

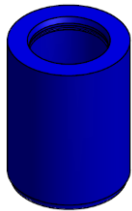
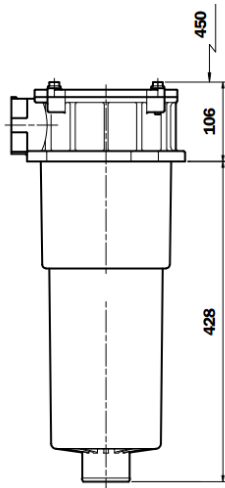

Cyclone infesting.
Tegn. Nr. 305-HP-007-10-P29

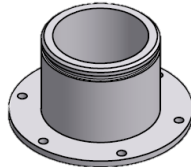
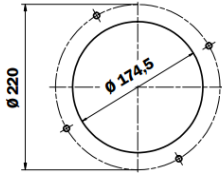

Distansering for filter.
Tegn. Nr. 305-010-P03



Pakning for distansering.
Tegn. Nr. 305-010-P04

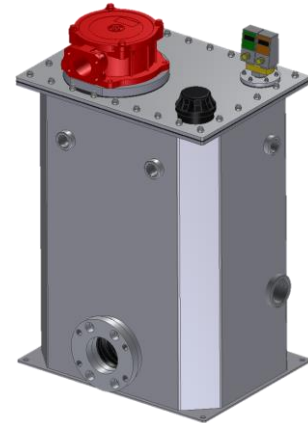
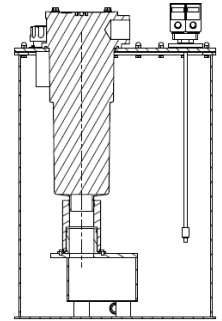

Art: 305016P02

Art: 305HP00710P29

Art: 305010P03

Art: 305010P04

	Length	A03	A06	A10	A16	A25	P10	P25	M25	M60
MPF750	1	390	450	625	700	780	700	750	900	900

Recommended maximum flow rate
 - Pressure drop of filter assembly equal to Δp 0,5 bar.
 - Oil kinematic viscosity 30 mm²/s (cSt).
 - Density 0,86 kg/dm³

HP-007-10

SERVI
GROUP™

SAE innløp
Tegn. nr. 305-HP-007-10-P28

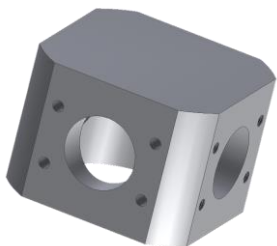
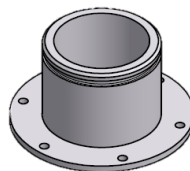

Plate.
Tegn. Nr. 305-HP-007-10-P23



Cyclone innfestning.
Tegn. Nr. 305-HP-007-10-P29



Rør
Hylse, tegn. nr. 305-HP-007-10-P25

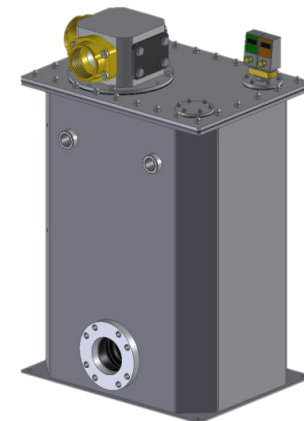
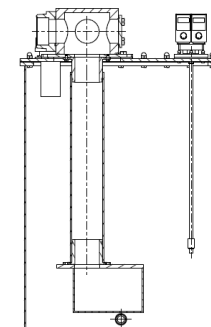

Art: 305HP00710P28

Art: 305HP00710P23

Art: 305HP00710P29

Art: 305HP00710P25

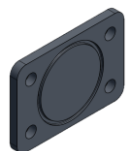

Blindplate
Tegn. Nr. 305-HP-007-10-P26

Art: 305HP00710P26



Pakning for plate
Tegn. Nr. 305-HP-007-10-P24

Art: 305HP00710P24

Recommended maximum flow rate
- Pressure drop of filter assembly
equal to Δp 0,5 bar.
- Oil kinematic viscosity 30 mm²/s (cSt).
- Density 0,86 kg/dm³

Servi Cyclone

SERVI
GROUP™



Heater 24V 250W
Art.nr: 6150432307



Nivåvakt m/ temp sensor
Art.nr: 726910

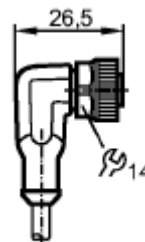

Kontakt for Nivåvakt med 5m kabel
Art.nr: EVC005

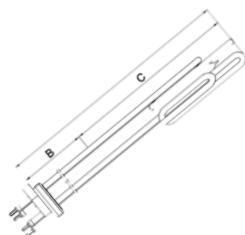

Heater 230V 1000W
Art.nr: 690031



Pustefilter

Art.nr	Beskrivelse
FMP000610	TA80-B-03-B-0-0-0-P01 Filler/Breather, Cork Gasket, Ø73/51 - 3 micron without strainer
FMP000274	TA80-B-03-A-2-0-1- P01 Filler/Breather valve 0,7 bar, NBR/Ø73/51 - 3 micron w/strainer L=80 mm
FMP000273	TA80-B-03-A-1-0-1-P01 Filler/Breather valve 0,3 bar, NBR/Ø73/51 - 3 micron w/strainer L=80 mm
FMP000270	TA80-B-03-B-0-0-1-P01 Filler/Breather Ø73/51 - 3 micron Cork Gasket - w/strainer L=80 mm
FMP000269	TA80-B-10-B-1-0-1-P01 Filler/Breather 10 micron, valve 0,3 bar, Cork gasket - Ø73/51 - 10 micron w/strainer L=80 mm
FMP000271	TA80-B-10-A-1-0-1-P01 Filler/Breather valve 0,3 bar, NBR/Ø73/51 - 10 micron w/strainer L=80 mm
FMP000272	TA80-B-10-A-2-0-1-P01 Filler/Breather valve 0,7 bar, NBR/Ø73/51 - 10 micron w/strainer L=80 mm
FMP000855	TAF80-B-03-A-9-L1-M-P01 Filler/Breather 3 my