

CYLINDER SERIES "ISO 15552" SERIES 3 Ø 32 ÷ 100 mm

Cylinders made to ISO 15552 available in various versions and with a wide range of accessories:

- Configuration with or without magnet
- Single- or double-acting – single- or through-rod
- Wide choice of NBR, POLYURETHANE and FKM/FPM gaskets (for high temperatures)
- Special versions on request
- Fixing accessories, guide units and mechanical piston rod lock.

The shape of series 3 cylinder liners is designed to reduce weight to a minimum.

Two T slots, on the same side as the threaded ports, to allow the insertion of retracting sensors.

The other three sides of the liner are smooth, with no grooving, to make them easier to clean.



TECHNICAL DATA	Polyurethane	NBR	FKM/FPM	Low Temperature
Operating pressure	max 10 bar (max 1 MPa - 145 psi)			
Temperature range Ø 32 ÷ 63	-20°C to +80°C (non-magnetic cyl.) -20°C to +70°C (magnetic cyl.)	-10°C to +80°C (non-magnetic cyl.) -10°C to +70°C (magnetic cyl.)	-10°C to +150° (non-magnetic cyl.)	-35°C to + 80°C
Ø 80 ÷ 100	-10°C to +80°C (non-magnetic cyl.) -10°C to +70°C (magnetic cyl.)	-10°C to +80°C (non-magnetic cyl.) -10°C to +70°C (magnetic cyl.)	-10°C to +150° (non-magnetic cyl.)	-35°C to + 80°C
Fluid	Unlubricated air. Lubrication, if used, must be continuous			
Bore	Ø 32 ; Ø 40 ; Ø 50 ; Ø 63 ; Ø 80 ; Ø 100			
Design	Heads with Tap Tite screws			
Standard stroke	Single-acting: for bores Ø 32-63, strokes 0-250 mm Double-acting: for bores Ø 32-80, strokes 25-2800 mm for bores Ø 100, strokes 25-2600 mm			
Versions	Double-acting cushioned, Single-acting retracted piston rod cushioned, Through-rod cushioned, High-temperature, Piston rod lock, Oil seal, Through-rod oil seal, Non-stick-slip*.			
Sensor magnet	All versions come complete with magnet. Supplied without magnet on request.			
Inrush pressure	Ø 32; 40: 0.4 bar Ø 50;63 strokes < 1500 mm: 0.3 bar; strokes ≥ 1500 mm: 0.4 bar Ø 80;100 strokes < 1500 mm: 0.2 bar; strokes ≥ 1500 mm: 0.4 bar			
Note on use	*Using for speeds lower than 0.2m/s, to prevent surging.			
Forces generated at 6 bar thrust/retraction	For no-stick-slip versions use no-lubricated air only			
Weights	See GENERAL TECHNICAL DATA PAGE 15 See GENERAL TECHNICAL DATA PAGE 15			

COMPONENTS

- ① PISTON ROD: C45 steel or stainless steel, thick chromed
- ② HEAD: die cast aluminium
- ③ PISTON ROD GASKET: polyurethane, NBR or FKM/FPM
- ④ GUIDE BUSHING: steel strip with bronze and PTFE insert
- ⑤ BARREL: drawn anodised calibrated aluminium
- ⑥ HALF-PISTON: self-lubricating technopolymer with built-in cushioning olives (aluminium with PTFE pad for diameters 80-100)
- ⑦ PISTON GASKET: polyurethane, NBR or FKM/FPM
- ⑧ MAGNET: plastoferrite
- ⑨ BUFFER + Static O-rings: NBR or FKM/FPM
- ⑩ CUSHIONING GASKET: polyurethane, NBR or FKM/FPM
- ⑪ CUSHIONING NEEDLE: OT 58 with needle out movement safety system even when fully open
- ⑫ SCREWS: Tap Tite for assembly

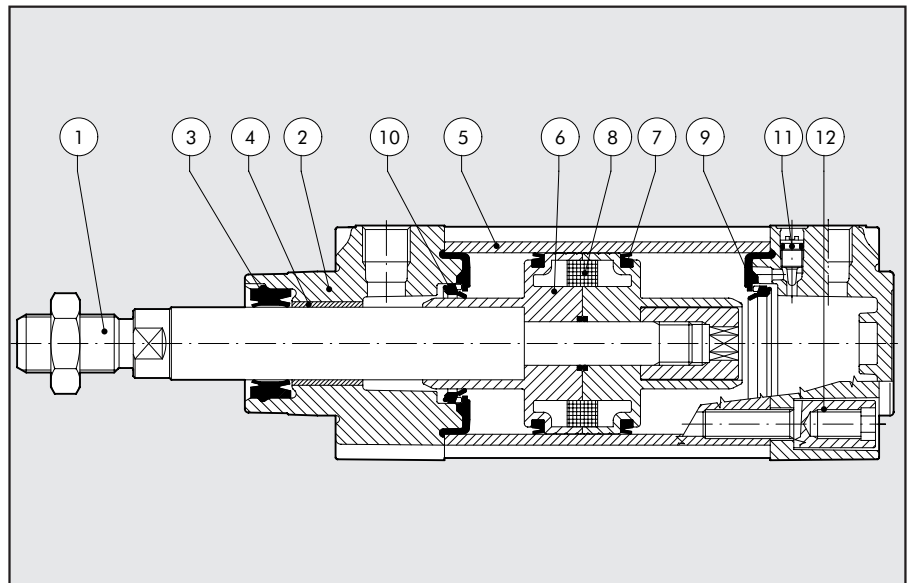

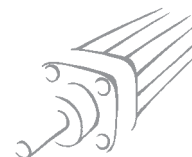

DIMENSIONS OF STANDARD VERSION

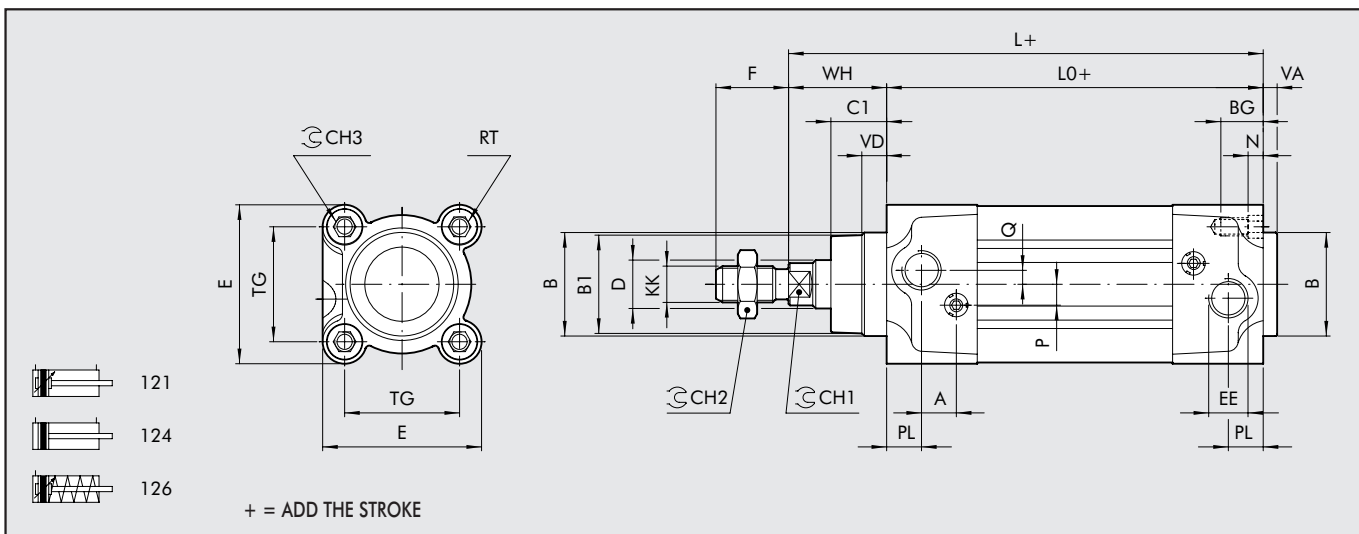

DIMENSIONS OF THROUGH-ROD VERSION

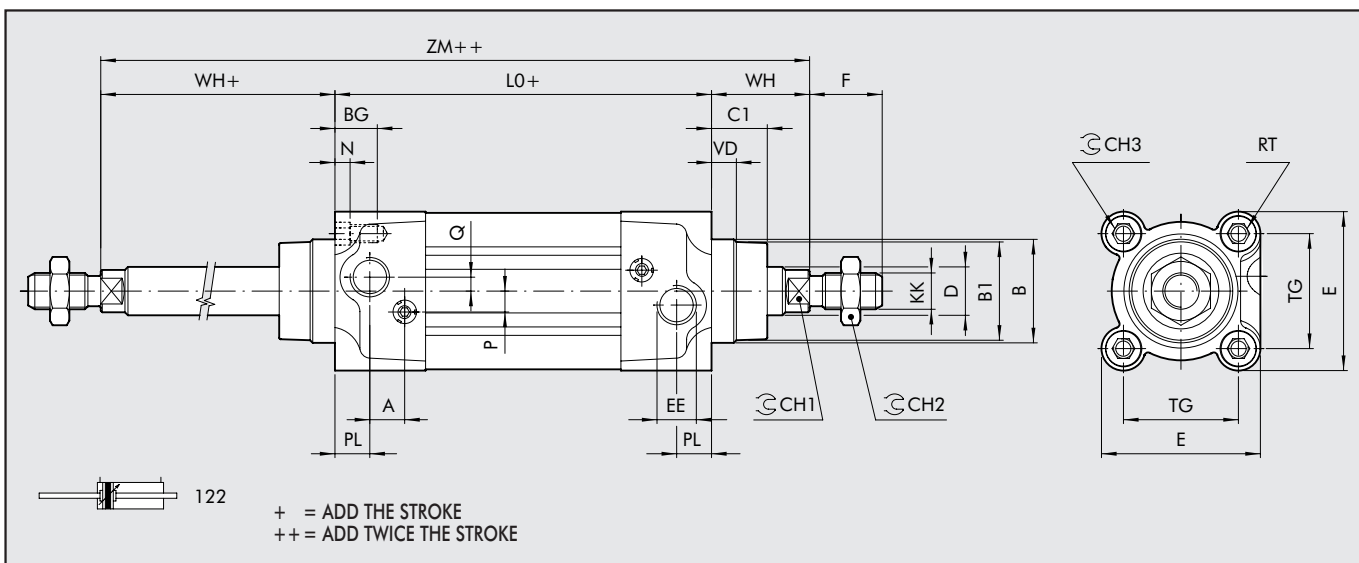

Ø	PL	VD	A	B	B ₁	WH	C ₁	CH ₁	CH ₂	CH ₃	KK	D	TG	VA	F	EE	RT	E	L	L ₀	ZM	BG	N	P	Q
32	10	6.5	10	30	28	26	16	10	17	6	M10x1.25	12	32.5	4	22	G1/8	M6	46	120	94	146	14.5	4.5	6	4
40	12	8	10	35	33	30	20	13	19	6	M12x1.25	16	38	4	24	G1/4	M6	54	135	105	165	14.5	4.5	6	4
50	14	13	10	40	38	37	25	17	24	8	M16x1.5	20	46.5	4	32	G1/4	M8	64.5	143	106	180	17.5	5.5	6	6
63	16	14	10	45	40	37	25	17	24	8	M16x1.5	20	56.5	4	32	G3/8	M8	75.5	158	121	195	17.5	5.5	6	6
80	18	12	12	45	43	46	33	22	30	10	M20x1.5	25	72	4	40	G3/8	M10	94	174	128	220	21.5	5.5	10	7
100	20	14	12	55	49	51	38	22	30	10	M20x1.5	25	89	4	40	G1/2	M10	111	189	138	240	21.5	5.5	10	7

VERSION 126 (SINGLE-ACTING)

	Upper limit	Stroke	Lower limit	L0 - Ø 32	L0 - Ø 40	L0 - Ø 50	L0 - Ø 63	L - Ø 32	L - Ø 40	L - Ø 50	L - Ø 63
ISO	0	< C ≤ 25	25	94	105	106	121	120	135	143	158
ISO	25	< C ≤ 50	50	94	105	106	121	120	135	143	158
NON ISO	50	< C ≤ 75	75	115	129.5	130.5	145.5	141	159.5	167.5	182.5
NON ISO	75	< C ≤ 100	100	136	154	155	170	162	184	192	207
NON ISO	100	< C ≤ 125	125	157	178.5	179.5	194.5	183	208.5	216.5	231.5
NON ISO	125	< C ≤ 150	150	178	203	204	219	204	233	241	256
NON ISO	150	< C ≤ 175	175	199	227.5	228.5	243.5	225	257.5	265.5	280.5
NON ISO	175	< C ≤ 200	200	220	252	253	268	246	282	290	305
NON ISO	200	< C ≤ 225	225	241	276.5	277.5	292.5	267	306.5	314.5	329.5
NON ISO	225	< C ≤ 250	250	262	301	302	317	288	331	339	354

DIMENSIONS OF TANDEM VERSION

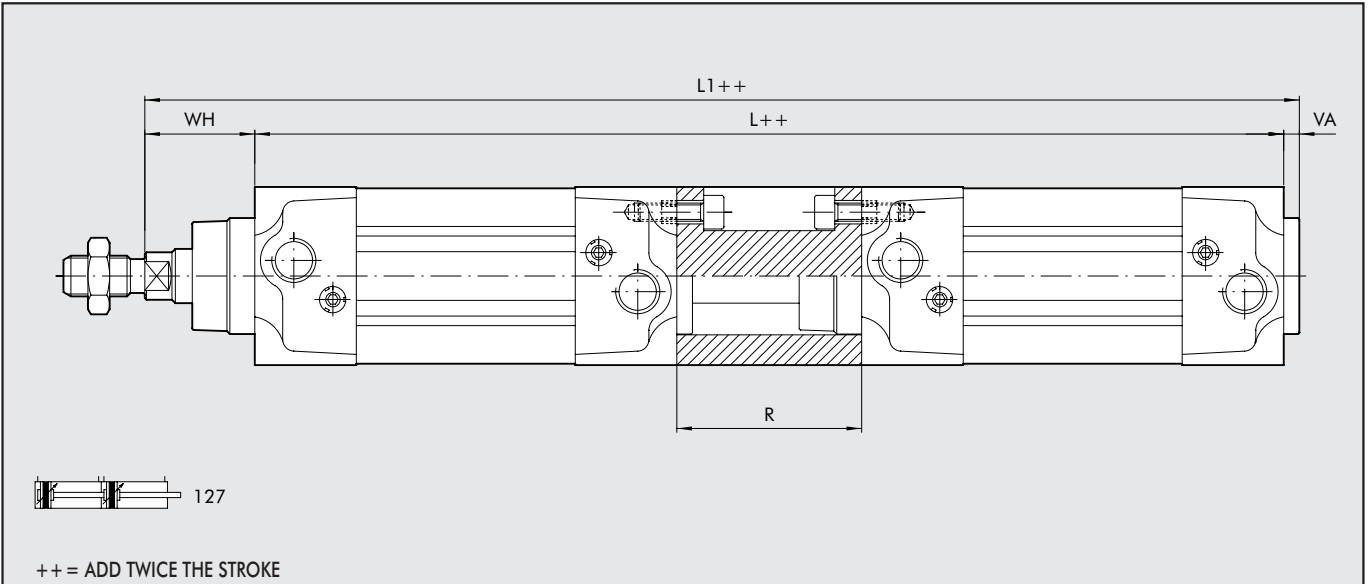

Ø	WH	VA	R	L	L ₁
32	26	4	55	243	273
40	30	4	55	265	299
50	37	4	68	280	321
63	37	4	68	310	351
80	46	4	92	348	398
100	51	4	92	368	423

Refer to standard cylinders for other values.

DIMENSIONS OF OPPOSED VERSION

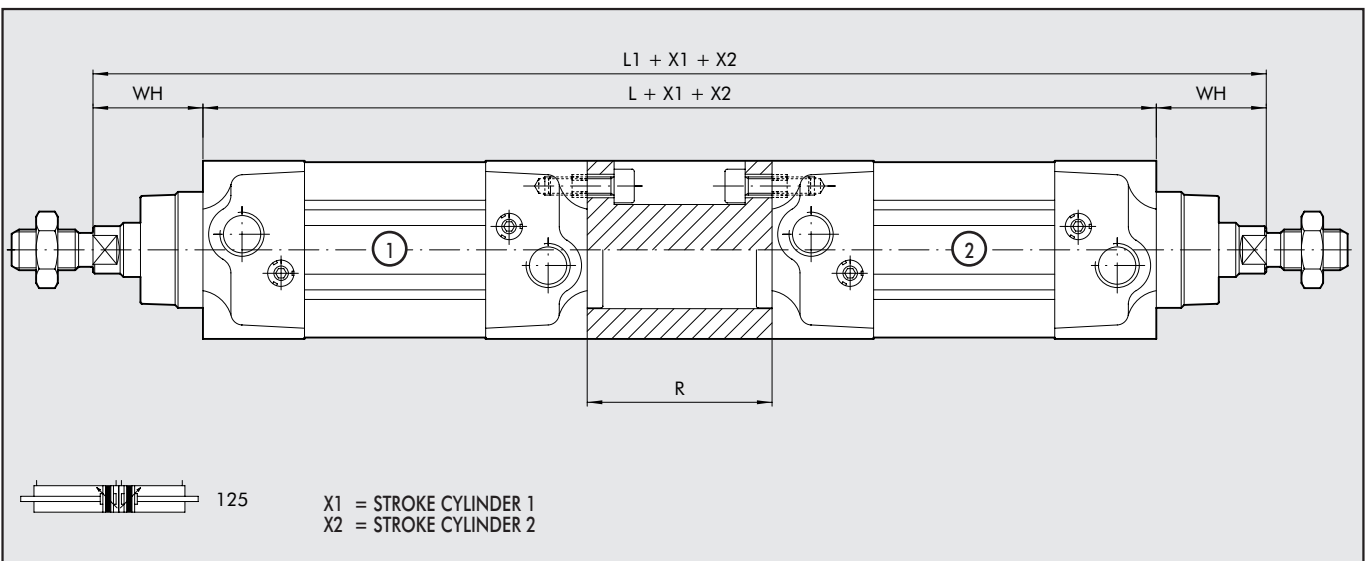

Ø	WH	R	L	L ₁
32	26	55	243	295
40	30	55	265	325
50	37	68	280	354
63	37	68	310	384
80	46	92	348	440
100	51	92	368	470

Refer to standard cylinders for other values.

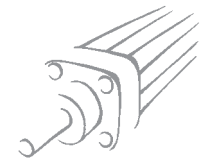

BARREL CROSS SECTION

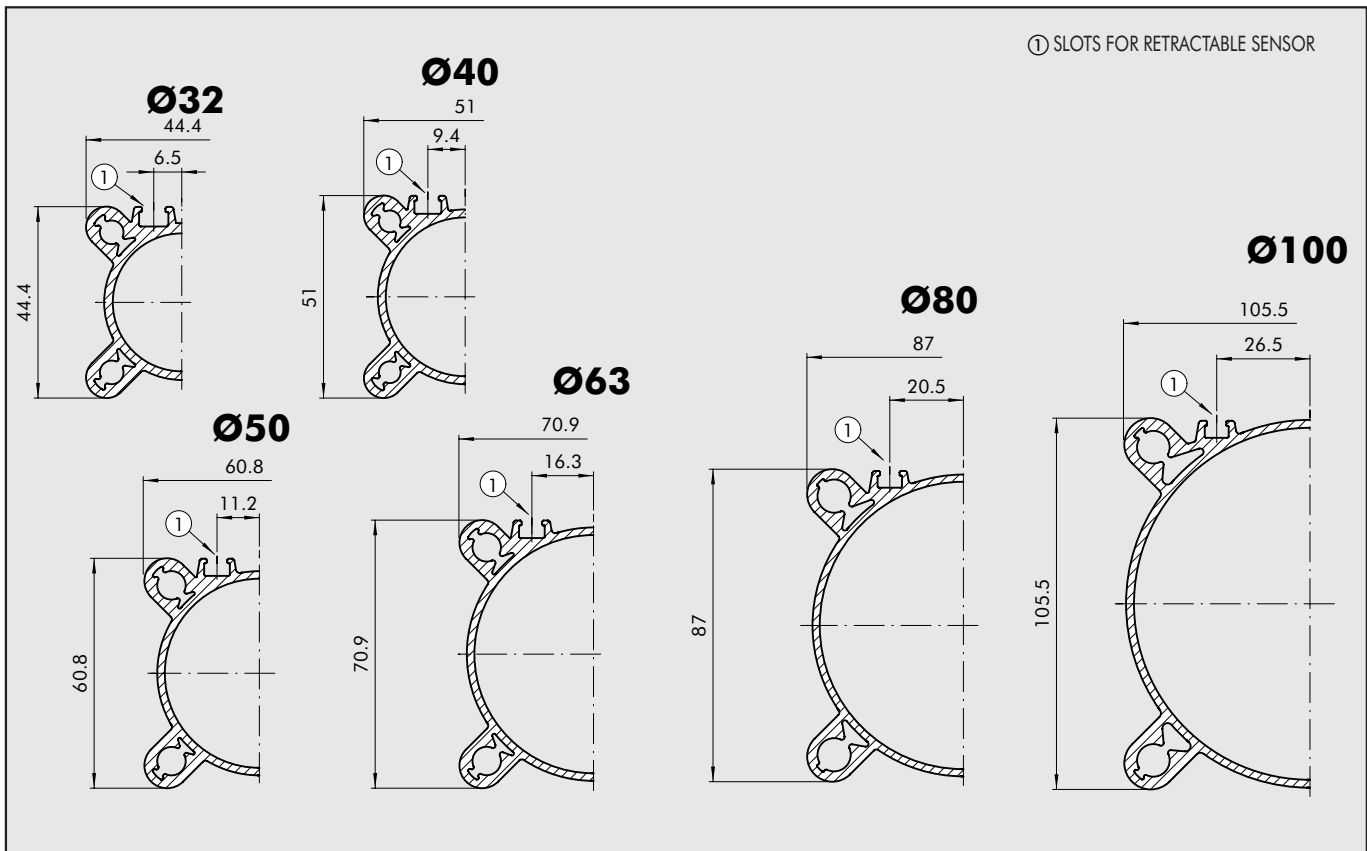

KEY TO CODES

CYL	1	2	1	3	3	2	0	0	5	0	C	N	
	TYPE				BORE		STROKE						
	121	Double-acting, cushioned		3	Series 3	32	For the maximum suppliable strokes, look at the technical data			A	C45 chromed rod, aluminium piston rod: standard for all cylinders with ≥ 1000 mm-stroke cylinders and for cylinder with ≥ 80 mm and over	N	NBR gaskets
	122	Through-rod		◆ 4	Series 3 No stick slip	40						P	polyurethane gaskets
	124	Double-acting, non-cushioned		5	Series 3 Non magnetic	50						V	FKM/FPM gaskets
	125	Opposed				63				C	C45 chromed rod, technopolymer piston: standard for cylinders of ≥ 32 to ≥ 63 mm with < 1000 mm strokes	● B	low temperature
	+ 126	Single-acting				80				Z	Stainless steel piston rod and nut aluminium piston		
	127	Tandem				A1=100				X	Stainless steel piston rod and nut technopolymer piston		
	134	Rod lock version											
	136	Version with piston rod lock											
	137	Piston rod lock + guide unit											

- Only available for versions with aluminium piston (A or Z)
- + Available until Ø63 and only the versions with piston in aluminium (A or Z)
- ◆ For speeds lower than 0.2m/s, to prevent surging. Use no-lubricated air only

ACCESSORIES ISO 1552 SERIES 3: MECHANICAL ROD BLOCK

Pilot pressure	Pp	4-8 bar (0.4-0.8 Mpa)
Ambient temperature	Te	Max 80°C (176°F)
Fluid temperature	tg	Max 70°C (154°F)
Operation		NC - bidirectional
Mechanics		Double shoe with mechanical lock
Locking force		Ø32 Ø40 Ø50 Ø63 Ø80 Ø100
	F	650 1100 1600 2500 4000 6300
Body material	(N)	Aluminium
Shoe material		Brass
Spring material		NBR
Piston material		Synthetic material with added teflon
Gasket material		NBR
Pilot port		1/8"



OPERATING PRINCIPLE

The mechanical piston rod lock is a normally-closed mechanism. In the absence of pneumatic piloting, the two shoes (A) lock the cylinder rod in both directions (Fig. 1). With pneumatic piloting, the piston rod guide forces the shoes to come right up to each other and overcome the counter spring (B) force and the piston rod can slide (Fig. 2). It is important to remember that the mechanical piston rod lock is a static type, which means that it is necessary to stop the cylinder piston rod pneumatically before locking the part mechanically.

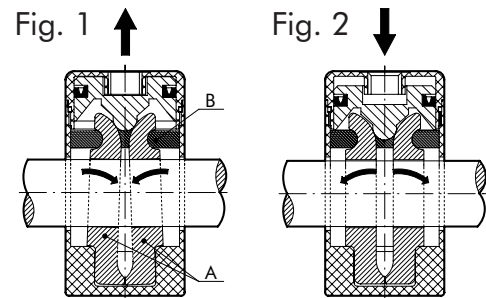

DIMENSIONS

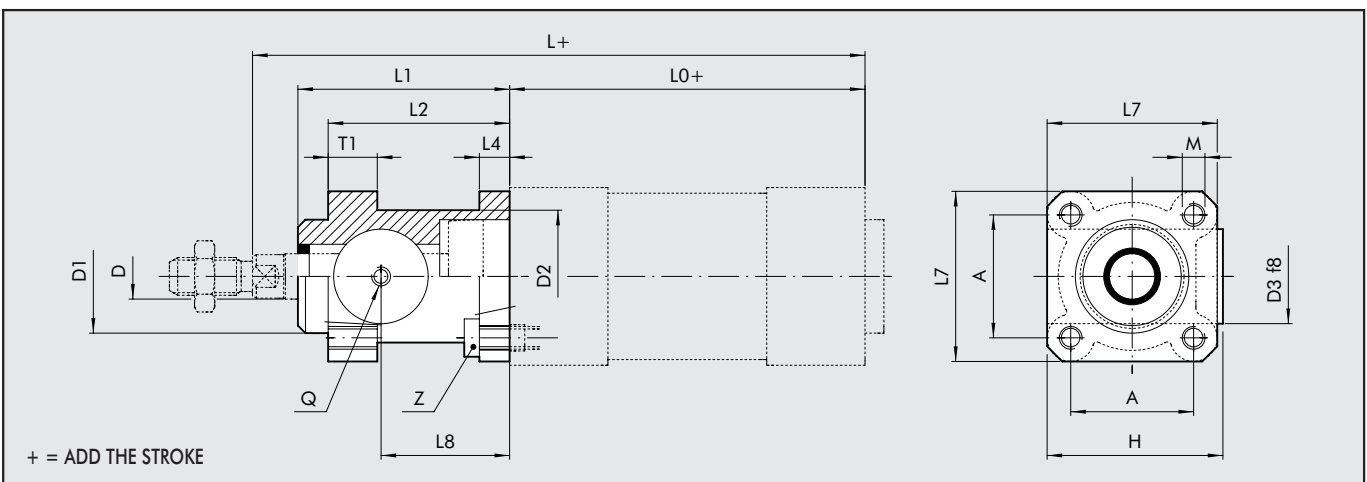

Code	Ø	L ₁	L ₂	L ₄	L ₇	L ₈	D	D ₁	D ₂	D ₃	H	A	T ₁	M	Z	Q	L ₀	L	Weight [g]
W5010001102	32	58	48	8	45	34	12	30	35	25	46.5	32.5	13	M6	M6x20	M5	94	162	150
W5010001103	40	65	55	8	50	38	16	35	40	28	53	38	13	M6	M6x20	G1/8	105	180	200
W5010001104	50	82	70	15	60	48	20	40	50	35	64	46.5	16	M8	M8x30	G1/8	106	200	500
W5010001109	63	82	70	15	70	49.5	20	45	60	38	75	56.5	16	M8	M8x30	G1/8	121	215	700
W5010001106	80	110	90	18	90	61	25	45	80	48	95	72	20	M10	M10x35	G1/8	128	251	1700
W5010001107	100	115	100	18	105	68	25	55	100	58	110.5	89	20	M10	M10x35	G1/8	138	266	2700

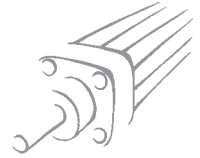

ACCESSORIES ISO 1552 SERIE 3: FIXINGS

1

FOOT - MODEL A

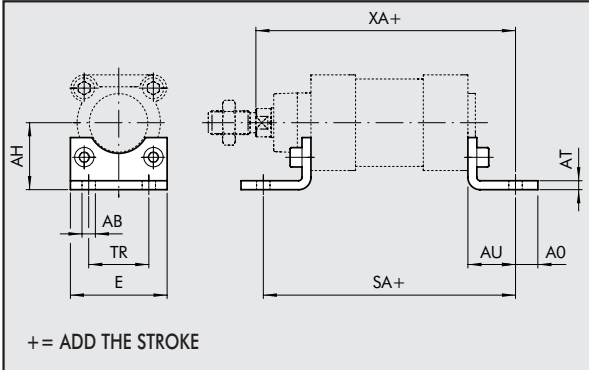

Code	Ø	Ø AB	AH	AO	AT	AU	TR	E	XA	SA	Weight [g]
W0950322001	32	7	32	11	4	24	32	45	144	142	76
W0950402001	40	9	36	15	4	28	36	52	163	161	100
W0950502001	50	9	45	15	4	32	45	65	175	170	162
W0950632001	63	9	50	15	6	32	50	75	190	185	266
W0950802001	80	12	63	20	6	41	63	95	215	210	456
W0951002001	100	14	71	25	6	41	75	115	230	220	572

Note: individually packed with 2 screws.

FEMALE HINGE - MODEL B

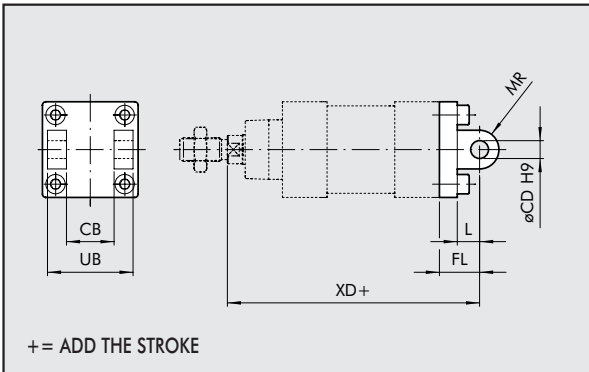

Code	Ø	UB	CB	FL	ØCD	XD	MR	L	Weight [g]
W0950322003	32	45	26	22	10	142	10	10	116
W0950402003	40	52	28	25	12	160	12	10	160
W0950502003	50	60	32	27	12	170	12	12	252
W0950632003	63	70	40	32	16	190	16	12	394
W0950802003	80	90	50	36	16	210	16	16	670
W0951002003	100	110	60	41	20	230	20	16	1085

Note: Supplied with 4 screws, 4 washers, 2 snap-rings, 1 pin.

MALE HINGE - MODEL BA

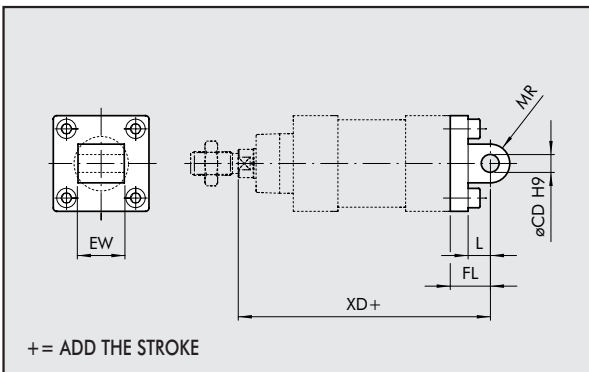

Code	Ø	EW	FL	MR	Ø CD	L	XD	Weight [g]
W0950322004	32	26	22	11	10	12	142	94
W0950402004	40	28	25	13	12	15	160	124
W0950502004	50	32	27	13	12	15	170	220
W0950632004	63	40	32	17	16	20	190	316
W0950802004	80	50	36	17	16	20	210	578
W0951002004	100	60	41	21	20	25	230	850

Note: Supplied with 4 screws, 4 washers

ARTICULATED MALE HINGE - MODEL BAS

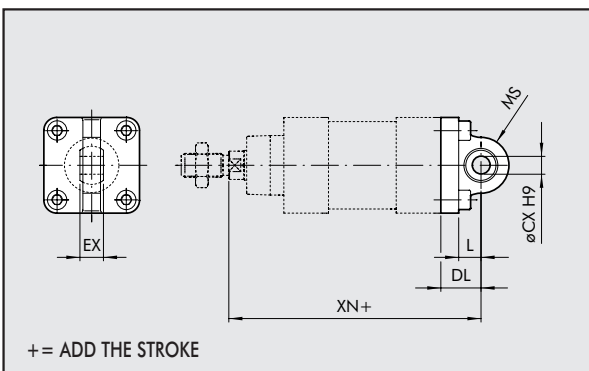

Code	Ø	DL	MS	L	XN	CX	EX	Weight [g]
W0950322006	32	22	16	12	142	10	14	106
W0950402006	40	25	19	15	160	12	16	142
W0950502006	50	27	19	15	170	12	16	236
W0950632006	63	32	24	20	190	16	21	336
W0950802006	80	36	24	20	210	16	21	572
W0951002006	100	41	30	25	230	20	25	840

Note: Supplied with 4 screws, 4 washers

6

CETOP HINGE FOR MODEL B - MODEL GL

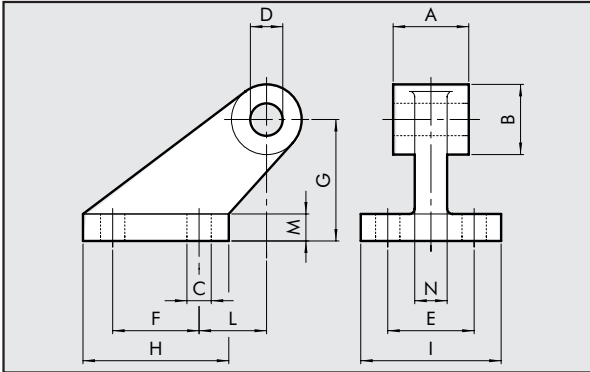

Code	Ø	A	B	C	D	E	F	G	H	I	L	M	N	Weight [g]
W0950322008	32	26	19	7	10	25	20	32	37	41	18	8	10	96
W0950402008	40	28	26	9	12	32	32	45	54	52	25	10	12	216
W0950502008	50	32	26	9	12	32	32	45	54	52	25	10	12	212
W0950632008	63	40	33	11	16	40	50	63	75	63	32	12	15	440
W0950802008	80	50	33	11	16	40	50	63	75	63	32	12	15	464
W0951002008	100	60	44	14	20	50	70	90	103	80	40	16	22	985

Note: Supplied with 4 screws, 4 washers

ISO HINGE FOR MODEL B - MODEL GS

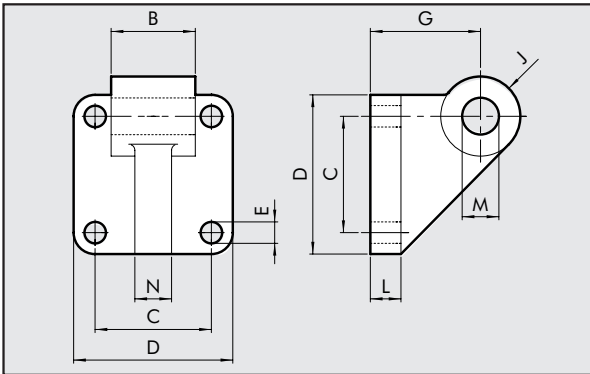

Code	Ø	B	C	D	E	G	J	L	M	N	Weight [g]
W0950322108	32	25.5	32.5	45	7	32	11	10	10	10	106
W0950402108	40	27.5	38	52	7	36	13	10	12	12	138
W0950502108	50	31.5	46.5	65	9	45	13	12	12	12	252
W0950632108	63	39.5	56.5	75	9	50	17	12	16	15	350
W0950802108	80	49.5	72	95	11	63	17	16	16	15	655
W0951002108	100	59.5	89	115	11	73	21	16	20	22	980

Note: Supplied with 4 screws, 4 washers

FRONT FLANGE - MODEL C

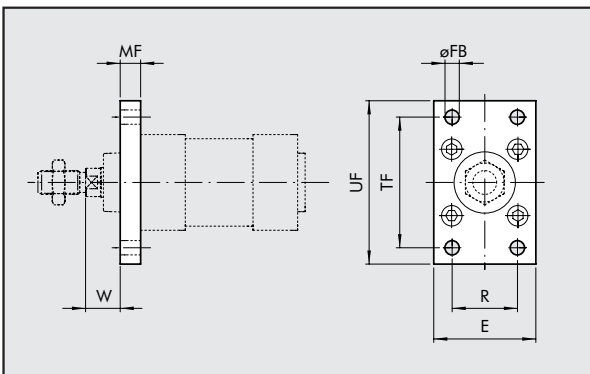

Code	Ø	TF	UF	E	MF	R	ØFB	W	Weight [g]
W0950322002	32	64	80	50	10	32	7	16	246
W0950402002	40	72	90	55	10	36	9	20	290
W0950502002	50	90	110	65	12	45	9	25	522
W0950632002	63	100	120	75	12	50	9	25	670
W0950802002	80	126	153	95	16	63	12	30	1420
W0951002002	100	150	178	115	16	75	14	35	2040

Note: Supplied with 4 screws.

REAR FLANGE - MODEL C

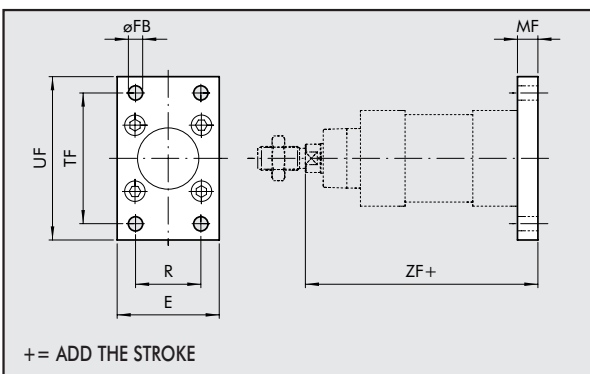

Code	Ø	TF	UF	E	MF	R	ØFB	ZF	Weight [g]
W0950322002	32	64	80	50	10	32	7	130	246
W0950402002	40	72	90	55	10	36	9	145	290
W0950502002	50	90	110	65	12	45	9	155	522
W0950632002	63	100	120	75	12	50	9	170	670
W0950802002	80	126	153	95	16	63	12	190	1420
W0951002002	100	150	178	115	16	75	14	205	2040

Note: Supplied with 4 screws.

+ = ADD THE STROKE



ROD NUT - MODEL S

Code Ø F H CH Weight [g]

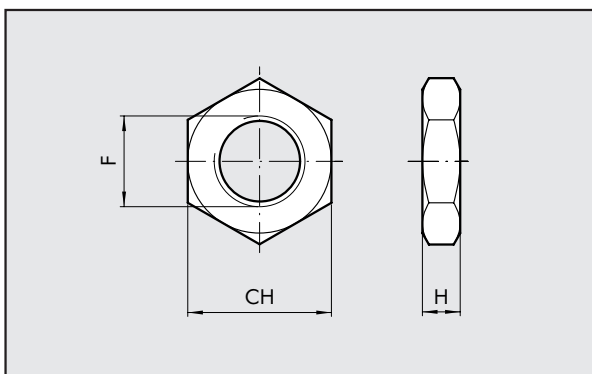

0950322010	32	M10x1.25	6	17	6
0950402010	40	M12x1.25	7	19	12
0950502010	50	M16x1.5	8	24	20
0950502010	63	M16x1.5	8	24	20
0950802010	80	M20x1.5	9	30	32
0950802010	100	M20x1.5	9	30	32

Note: Individually packed.

FORK MODEL GK-M

Code Ø Ø M C B A L F D N Weight [g]

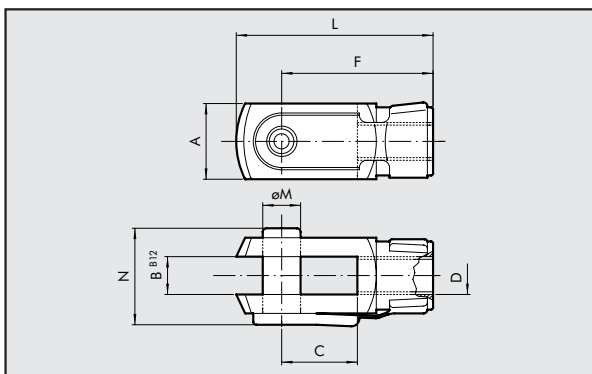

W0950322020	32	10	20	10	20	52	40	M10x1.25	26	92
W0950402020	40	12	24	12	24	62	48	M12x1.25	32	148
W0950502020	50	16	32	16	32	83	64	M16x1.5	40	340
W0950502020	63	16	32	16	32	83	64	M16x1.5	40	340
W0950802020	80	20	40	20	40	105	80	M20x1.5	40	690
W0950802020	100	20	40	20	40	105	80	M20x1.5	48	690

Note: Individually packed.

ROD EYE - MODEL GA-M

Code Ø Ø M C B1 B A L F D Ø G CH Ø G1 Weight [g]

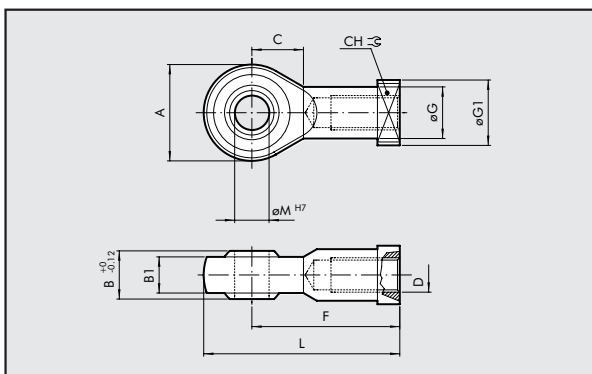

W0950322025	32	10	15	10.5	14	28	57	43	M10x1.25	15	17	19	78
W0950402025	40	12	17	12	16	32	66	50	M12x1.25	17.5	19	19	116
W0950502025	50	16	22	15	21	42	85	64	M16x1.5	22	22	22	226
W0950502025	63	16	22	15	21	42	85	64	M16x1.5	22	22	22	226
W0950802025	80	20	26	18	25	50	102	77	M20x1.5	27.5	30	27	404
W0950802025	100	20	26	18	25	50	102	77	M20x1.5	27.5	30	27	404

Note: Individually packed

SELF ALIGNING ROD COUPLER - MODEL GA-K

Code Ø A B C D ØF ØE SW₁ SW₂ SW₃ SW₄ SW₅ Weight [g]

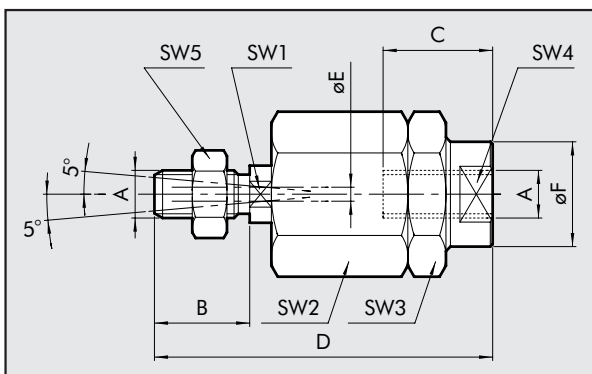

W0950322030	32	M10x1.25	20	20	71	22	4	12	30	30	19	17	216
W0950402030	40	M12x1.25	24	20	75	22	4	12	30	30	19	19	220
W0950502030	50	M16x1.5	32	32	103	32	4	20	41	41	30	24	620
W0950502030	63	M16x1.5	32	32	103	32	4	20	41	41	30	24	620
W0950802030	80	M20x1.5	40	40	119	32	4	20	41	41	30	30	680
W0950802030	100	M20x1.5	40	40	119	32	4	20	41	41	30	30	680

Note: Individually packed

ACCESSORIES: MAGNETIC SENSORS

RETRACTABLE SENSOR WITH INSERTION FROM ABOVE

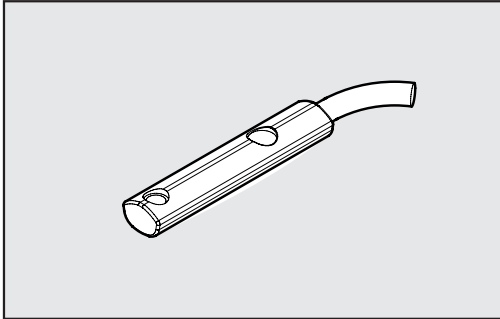

Code	Description
W0952025390	HALL N.O. SENSOR, VERTICAL INSERTION 2.5m
W0952029394	HALL N.O. SENSOR, VERTICAL INSERTION 300 mm M8
W0952022180	REED N.O. SENSOR, VERTICAL INSERTION 2.5m
W0952028184	REED N.O. SENSOR, VERTICAL INSERTION 300 mm M8
W0952125556	HALL N.O. SENSOR, VERTICAL INSERTION 2m ATEX

This type of sensor can be inserted in the slot of the sensor from above. This means the cylinder heads do not require a through opening.

WIRING DIAGRAM

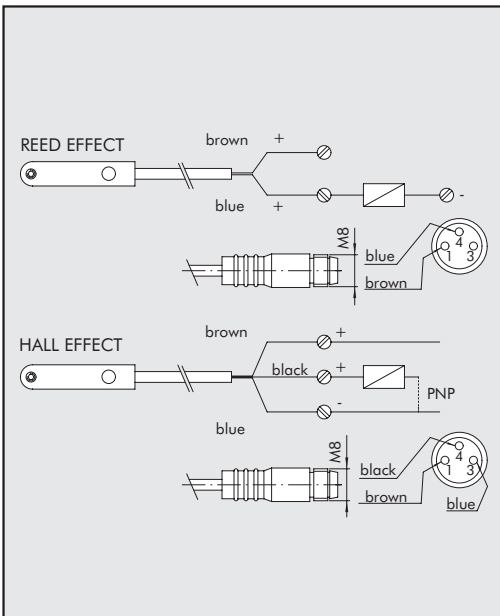

TECHNICAL DATA

	Reed	Effetto Hall	Effetto Hall
Type of contact	N.O.	N.O.	N.O.
Switch	-	PNP	PNP
Supply voltage (U _b)	V 10 ÷ 30 AC/DC	10 ÷ 30 DC	18 ÷ 30 DC
Power	W 3 (peak valve=6)	3	≤ 1.7
Voltage variation	-	≤ 10% di U _b	≤ 10% di U _b
Voltage drop	V -	≤ 2	≤ 2.2
Input current	mA -	≤ 10	≤ 10
Output current	mA ≤ 100	≤ 100	≤ 70
Switching frequency	Hz ≤ 400	≤ 5000	1000
Short-circuit protection	-	Yes	Yes
Over-voltage suppression	-	Yes	Yes
Polarity inversion protection	-	Yes	Yes
EMC	EN 60 947-5-2	EN 60 947-5-2	EN 60 947-5-2
LED display	Yellow	Yellow	Yellow
Magnetic sensitivity	2,8 mT ±25%	2,8 mT ±25%	2.6
Repeatability	≤ 0,1 mT	≤ 0,1 mT	≤ 0,1 (U _b and to fixed)
Degree of protection (EN 60529)	IP 67	IP 67	IP 68, IP 69K
Vibration and shock resistance	30 g, 11 ms, 10÷55 Hz, 1mm	30 g, 11 ms, 10÷55 Hz, 1mm	30 g, 11 ms, 10÷55 Hz, 1mm
Temperature range	°C -25 ÷ +75	-25 ÷ +75	-20 ÷ +45
Sensor capsule material	PA66 + PA6I/6T	PA66 + PA6I/6T	PA
2.5m/2m connecting cable	PVC; 2 x 0,12 mm ²	PVC; 3 x 0,14 mm ²	PVC; 3 x 0,12 mm ²
Connecting cable with M8x1	Polyurethane; 2 x 0,14 mm ²	Polyurethane; 3 x 0,14 mm ²	-
Wire NO.	2	3	3

STRIP

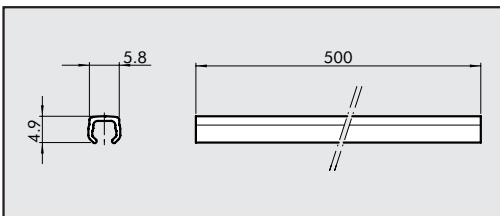

Code	Description
W0950000160	SLOT STRIP 500 mm

Note: The code corresponds to 1 piece.

KIT FOR CYLINDER ASSEMBLY WITH SENSOR SLOTS

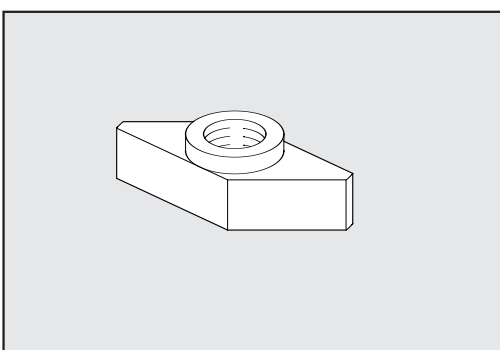

Code	Description	Weight [g]
0950003001	ACC. M4 T-SLOTTED FIXING PLATE	1
0950003002	ACC. M3 T-SLOTTED FIXING PLATE	1

Note: Individually packed

CYLINDERS ISO 1552 SERIES 3: SPARES



1

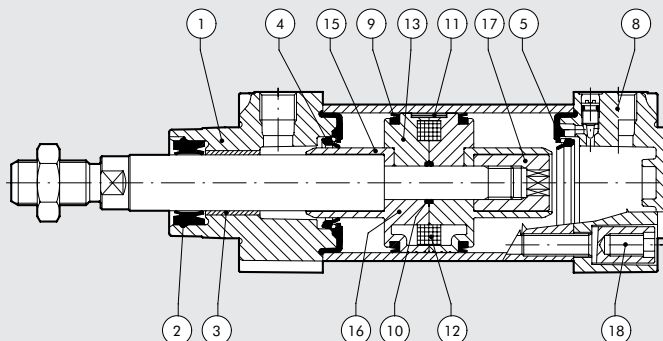

Type	Parts	Bore	Code
Complete set of polyurethane gaskets	2-4-5-9-10	Ø 32÷100	009 ... 0101
Complete set of NBR gaskets	2-4-5-9-10	Ø 32÷100	009 ... 0502
Complete polyurethane front head kit	1-2-3-4-5-17-18	Ø 32÷100	009 ... 0110N
Complete NBR front head kit	1-2-3-4-5-17-18	Ø 32÷100	009 ... 0304N
Complete polyurethane rear head kit	4-5-8-17-18	Ø 32÷100	009 ... 0111N
Complete NBR rear head kit	4-5-8-17-18	Ø 32÷100	009 ... 0305N
Complete polyurethane piston kit	9-10-16-17	Ø 32÷63	009 ... 0604
Complete polyurethane piston kit	9-10-11-13-15-18	Ø 80÷100	009 ... 0604
Complete NBR piston kit	9-10-16-17	Ø 32÷63	009 ... 0602
Complete NBR piston kit	9-10-11-13-15-18	Ø 80÷100	009 ... 0602
Complete polyurethane head A+P+piston kit	1-2-3-4-5-8-9-10-16-17-18	Ø 32÷63	009 ... 0704N
Complete polyurethane head A+P+piston kit	1-2-3-4-5-8-9-10-11-13-15-17-18	Ø 80÷100	009 ... 0704N
Complete NBR head A+P+piston kit	1-2-3-4-5-8-9-10-14-16-17-18	Ø 32÷63	009 ... 0702N
Complete NBR head A+P+piston kit	1-2-3-4-5-8-9-10-11-13-15-17-18	Ø 80÷100	009 ... 0702N
Magnet	12	Ø 32÷100	009 ... 0800

NOTES

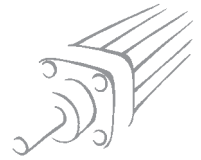

GRAPH OF GUIDE UNIT LOADS

1

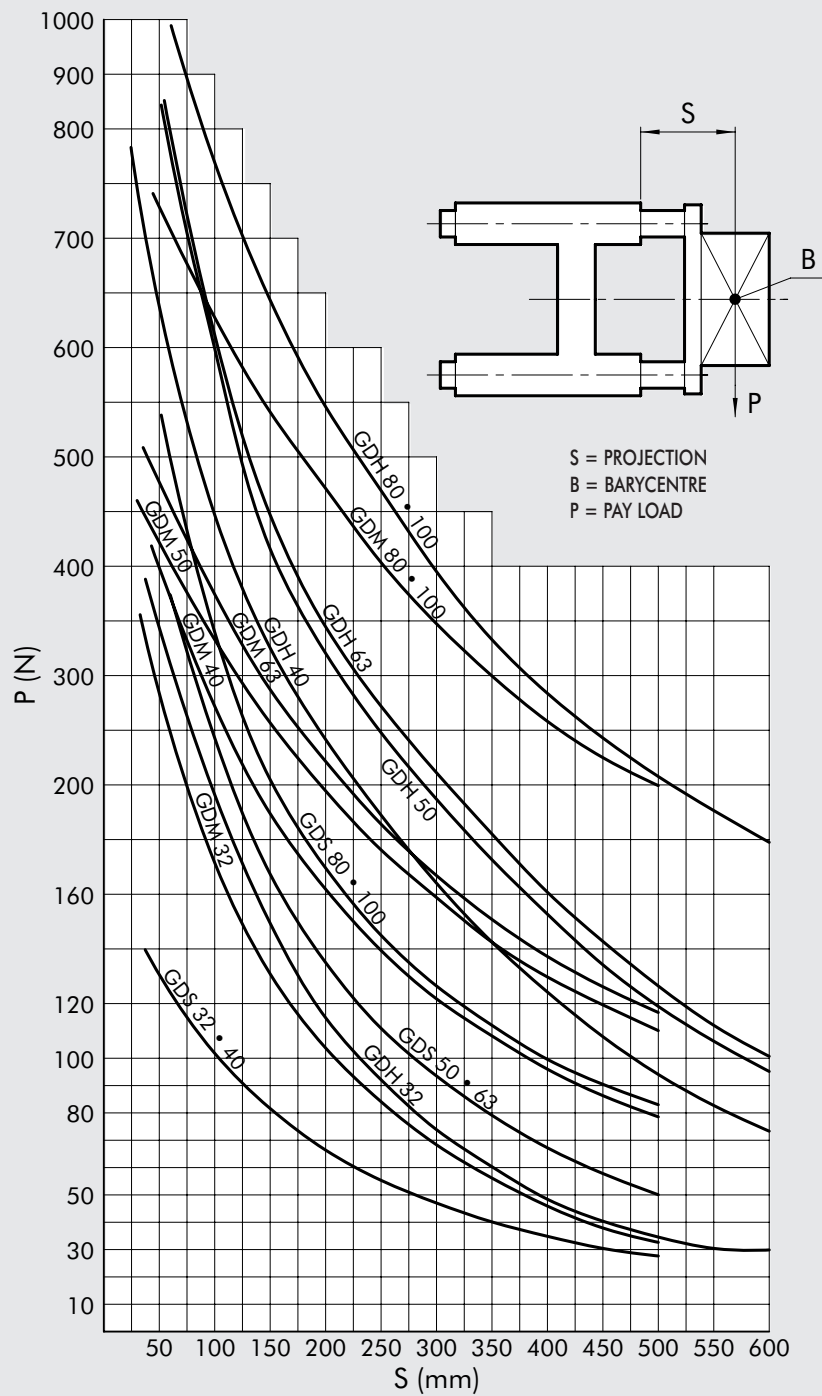

DIMENSIONS TYPE GDS

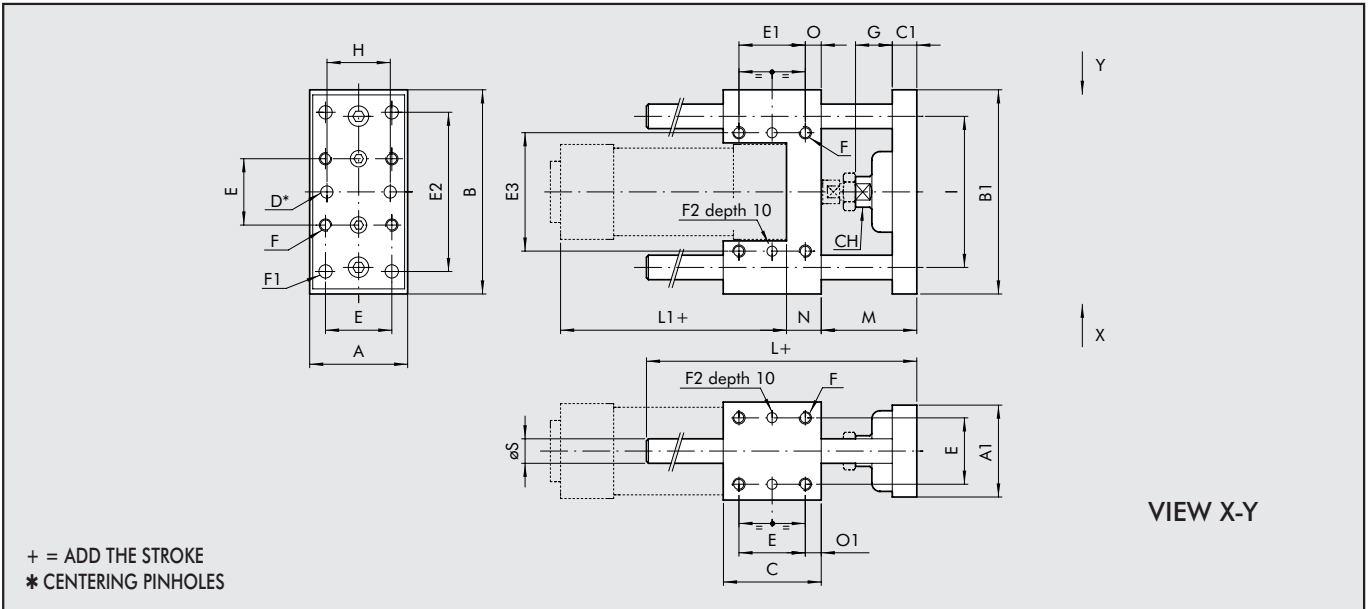

Ø	A	A ₁	B	B ₁	C	C ₁	D ^{H7}	E	E ₁	E ₂	E ₃	F	F ₁	F ₂ ^{H7}	G	H	I	L	L ₁	M	N	O	O ₁	Ø S	Ch
32	48	45	100	95	48	12	6	32.5	32.5	78	58	M6	6.5	6	18	31	74	108	94	46	17	7.8	7.8	12	15
40	56	53	106	101	58	15	6	38	38	84	64	M6	6.5	6	21	36	80	120	105	52	21	10	10	12	15
50	66	63	125	120	59	15	6	46.5	46.5	100	80	M8	8.5	6	24	45	96	130	106	65	25	6.3	6.3	16	22
63	76	73	132	127	76	15	6	56.5	56.5	105	95	M8	8.5	6	24	45	104	145	121	65	25	9.8	9.8	16	22
80	98	95	165	160	90	16	6	72	50	130	130	M10	11	6	31	56	130	170	128	71	34	20	9	20	27
100	118	115	185	180	110	16	6	89	70	150	150	M10	11	6	31	56	152	190	138	71	39	20	10.5	20	27

DIMENSIONS TYPE GDH-GDM

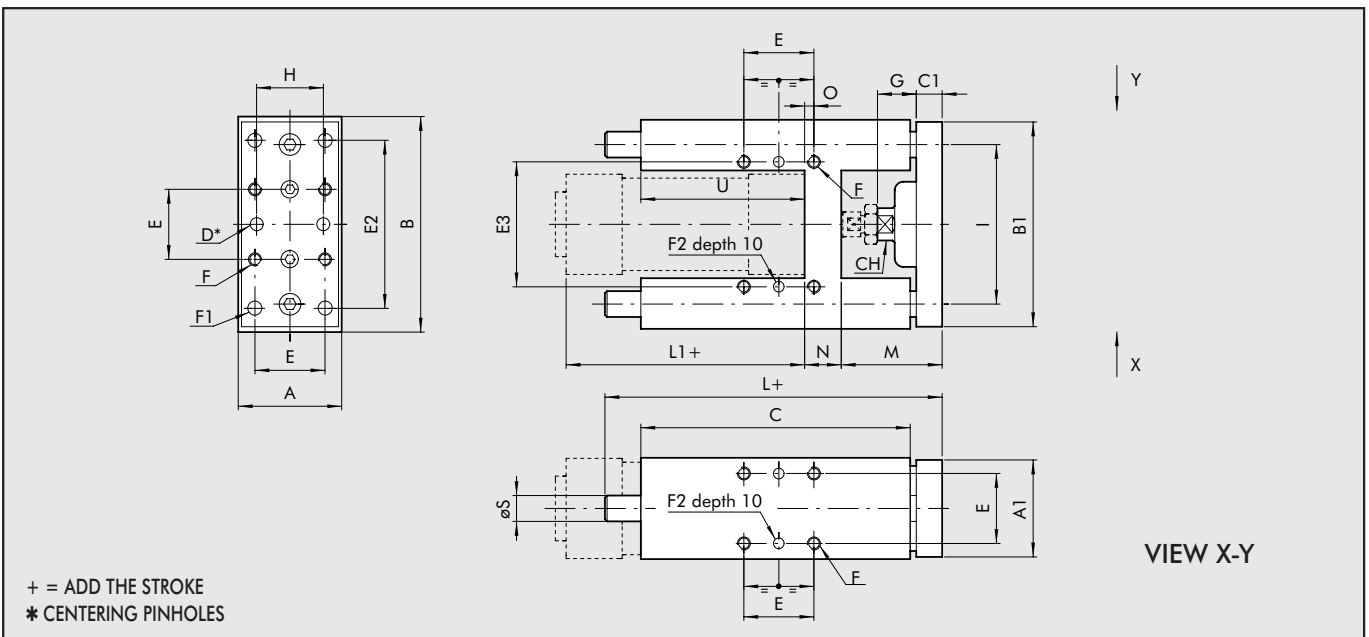

Ø	A	A ₁	B	B ₁	C	C ₁	Ch	D ^{H7}	E	E ₂	E ₃	F	F ₁	F ₂ ^{H7}	G	H	I	L	L ₁	M	N	O	Ø S	U
32	49	45	97	90	125	12	13	6	32.5	78	61	M6	6.5	6	18	31	74	177	94	47	17	4.3	12	76
40	58	54	115	110	139	15	15	6	38	84	69	M6	6.5	6	21	36	87	192	105	53	21	11	16	81
50	69	63	137	130	148	15	22	6	46.5	100	85	M8	8.5	6	24	45	104	205	106	63	26	18.5	20	78
63	85	79	152	145	182	15	22	6	56.5	105	100	M8	8.5	6	24	45	119	237	121	62	26	15.3	20	111
80	105	99	189	180	215	20	27	6	72	130	130	M10	11	6	31	56	148	280	128	76	34	21	25	128
100	129	120	213	200	220	20	27	6	89	150	150	M10	11	6	31	56	172	280	138	76	39	24.5	25	128

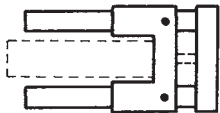
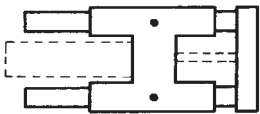
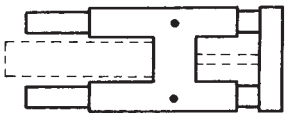

GUIDE UNIT

Version	Bore	Type	Code
Sliding on bronze bushings (GDS) 	32	UNIT MW DS 032...	W 0700321...
	40	UNIT MW DS 040...	W 0700401...
	50	UNIT MW DS 050...	W 0700501...
	63	UNIT MW DS 063...	W 0700631...
	80	UNIT MW DS 080...	W 0700801...
	100	UNIT MW DS 100...	W 0701001...
Sliding on bronze bushings (GDH) 	32	UNIT MW DH 032...	W 0700322...
	40	UNIT MW DH 040...	W 0700402...
	50	UNIT MW DH 050...	W 0700502...
	63	UNIT MW DH 063...	W 0700632...
	80	UNIT MW DH 080...	W 0700802...
	100	UNIT MW DH 100...	W 0701002...
Sliding on ball bearing (GDM) 	32	UNIT MW DM 032...	W 0700323...
	40	UNIT MW DM 040...	W 0700403...
	50	UNIT MW DM 050...	W 0700503...
	63	UNIT MW DM 063...	W 0700633...
	80	UNIT MW DM 080...	W 0700803...
	100	UNIT MW DM 100...	W 0701003...

Note: To complete the type and code, add the 3-digit stroke (e.g. 50=050)

DIMENSIONS PISTON ROD LOCK + GUIDE UNIT COD. 137

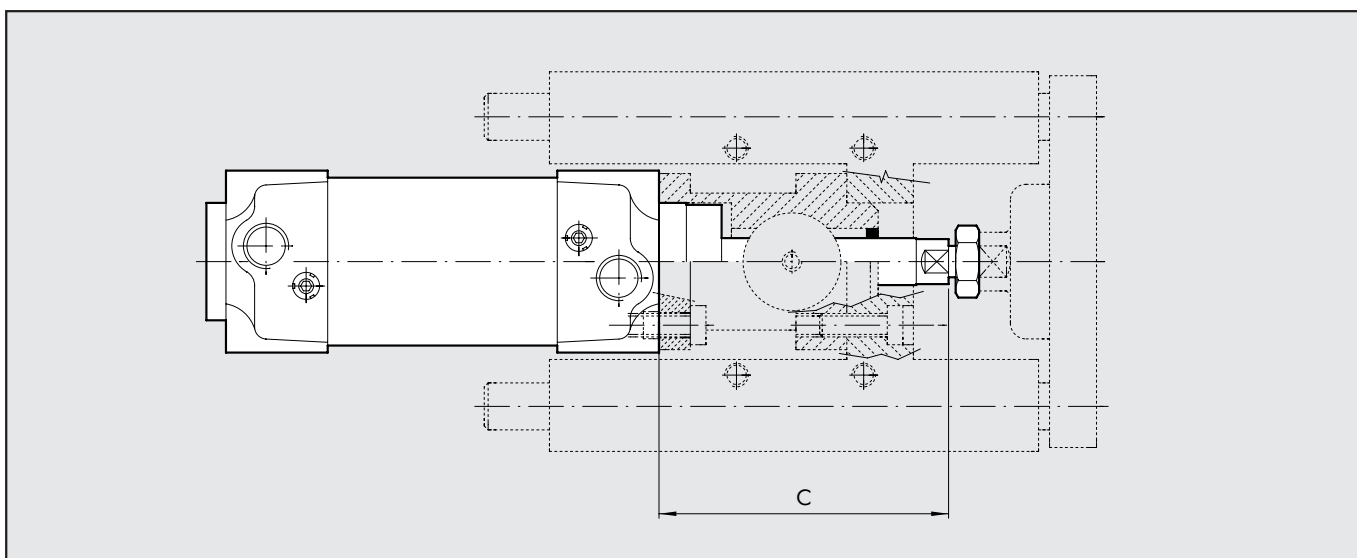

Ø	C
32	74
40	85
50	107
63	107
80	136
100	143

GENERALE TECHNICAL DATE

FORCES GENERATED DURING THRUST AND TRACTION (THEORETICAL)

Cylinder bore D mm	Piston rod diameter d mm	Motion	Useful area cm ²	Thrust and traction force in daN depending on the operating pressure in bar.									
				1 bar	2 bar	3 bar	4 bar	5 bar	6 bar	7 bar	8 bar	9 bar	10 bar
32	12	thrust	8.04	8.0	16.1	24.1	32.2	40.2	48.3	56.3	64.3	72.4	80.4
		traction	6.91	6.9	13.8	20.7	27.6	34.6	41.5	48.4	55.3	62.2	69.1
40	12	thrust	12.57	12.6	25.1	37.7	50.3	62.8	75.4	88.0	100.5	113.1	125.7
		traction	11.44	11.4	22.9	34.3	45.7	57.2	68.6	80.0	91.5	102.9	114.4
40	16	thrust	12.57	12.6	25.1	37.7	50.3	62.8	75.4	88.0	100.5	113.1	125.7
		traction	10.56	10.6	21.1	31.7	42.2	52.8	63.3	73.9	84.4	95.0	105.6
50	16	thrust	19.63	19.6	39.3	58.9	78.5	98.2	117.8	137.4	157.1	176.7	196.3
		traction	17.62	17.6	35.2	52.9	70.5	88.1	105.7	123.4	141.0	158.6	176.2
50	20	thrust	19.63	19.6	39.3	58.9	78.5	98.2	117.8	137.4	157.1	176.7	196.3
		traction	16.49	16.5	33.0	49.5	66.0	82.5	99.0	115.5	131.9	148.4	164.9
63	16	thrust	31.17	31.2	62.3	93.5	124.7	155.9	187.0	218.2	249.4	280.6	311.7
		traction	29.16	29.2	58.3	87.5	116.6	145.8	175.0	204.1	233.3	262.5	291.6
63	20	thrust	31.17	31.2	62.3	93.5	124.7	155.9	187.0	218.2	249.4	280.6	311.7
		traction	28.03	28.0	56.1	84.1	112.1	140.2	168.2	196.2	224.2	252.3	280.3
80	20	thrust	50.27	50.3	100.5	150.8	201.1	251.3	301.6	351.9	402.1	452.4	502.7
		traction	47.12	47.1	94.2	141.4	188.5	235.6	282.7	329.9	377.0	424.1	471.2
80	25	thrust	50.27	50.3	100.5	150.8	201.1	251.3	301.6	351.9	402.1	452.4	502.7
		traction	45.36	45.4	90.7	136.1	181.4	226.8	272.1	317.5	362.9	408.2	453.6
100	25	thrust	78.54	78.5	157.1	235.6	314.2	392.7	471.2	549.8	628.3	706.9	785.4
		traction	73.63	73.6	147.3	220.9	294.5	368.2	441.8	515.4	589.0	662.7	736.3

WEIGHT OF CYLINDERS

Cylinder "ISO 15552" Series 3					Guide unit				
Ø	Single-rod		Through-rod		Ø	Type GDS		Type GDH and GDM	
	Weight [g] Stroke=0	Weight [g] each mm	Weight [g] Stroke=0	Weight [g] each mm		Weight [g] Stroke=0	Weight [g] each mm	Weight [g] Stroke=0	Weight [g] each mm
32	410	1.64	471	2.53	32	772	1.76	1200	1.76
40	608	2.09	731	3.67	40	1000	1.76	2000	3.13
50	1016	3.02	1277	5.49	50	1900	3.13	3300	4.9
63	1348	3.36	1623	5.77	63	2300	3.13	4750	4.9
80	2705	5.37	3150	8.04	80	3800	4.9	8500	7.26
100	3768	6.57	4296	10.11	100	7000	4.9	12000	7.26

NOTES

METAL WORK S.p.A
 Head office: Via Segni, 5-7-9 25062 - Concesio (Brescia) Italy - Tel. 030 21 87 11 - Fax 030 21 80 569
 www.metalwork.it - metalwork@metalwork.it
 The dimensions shown in this catalogue are subject to variations at any time without prior notice