

GRT

LOW PROFILE TO GRIP FORCE RATIOS

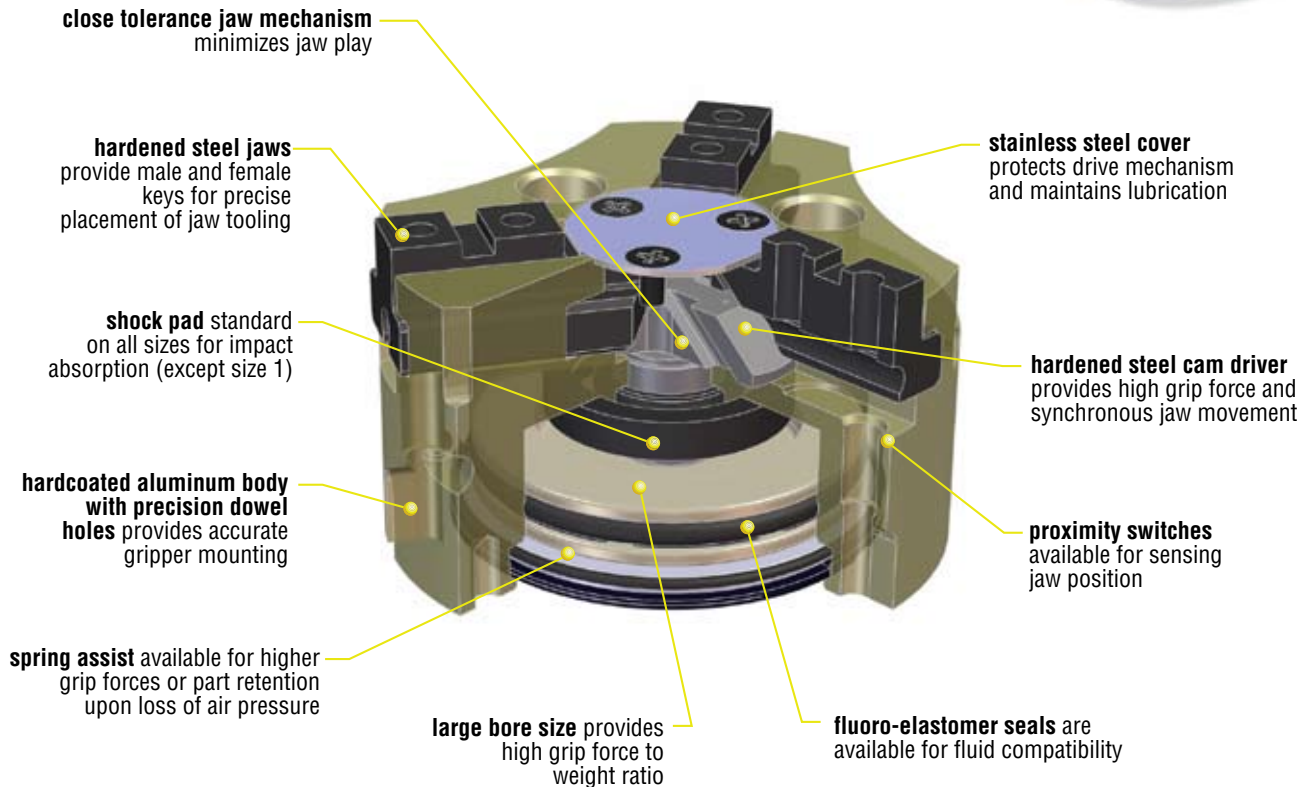

Eight Bore
Sizes!



GRT

Major Benefits

- 3 jaw design provides self-centering and maximum contact between part and jaw tooling
- Low profile to grip force and jaw travel ratios
- Eight sizes available in both imperial and metric versions
- Synchronous jaw motion
- Standard male and female keys on jaws
- Spring assist on open or close available
- Part ejector option assists in part location upon release
- 1-2 day shipping
- 10 million cycles minimum rated life with standard seals (includes spring assist units)

Industry Uses

- Assembly machine builders
- Light bulb manufacturing
- Packaging
- Automotive
- Robotics
- Golf equipment
- Plumbing fixtures

TO ORDER, SPECIFY:

Product Type, Series, Type, Style, Size, Jaw Style, Design No., Options, and Seals.

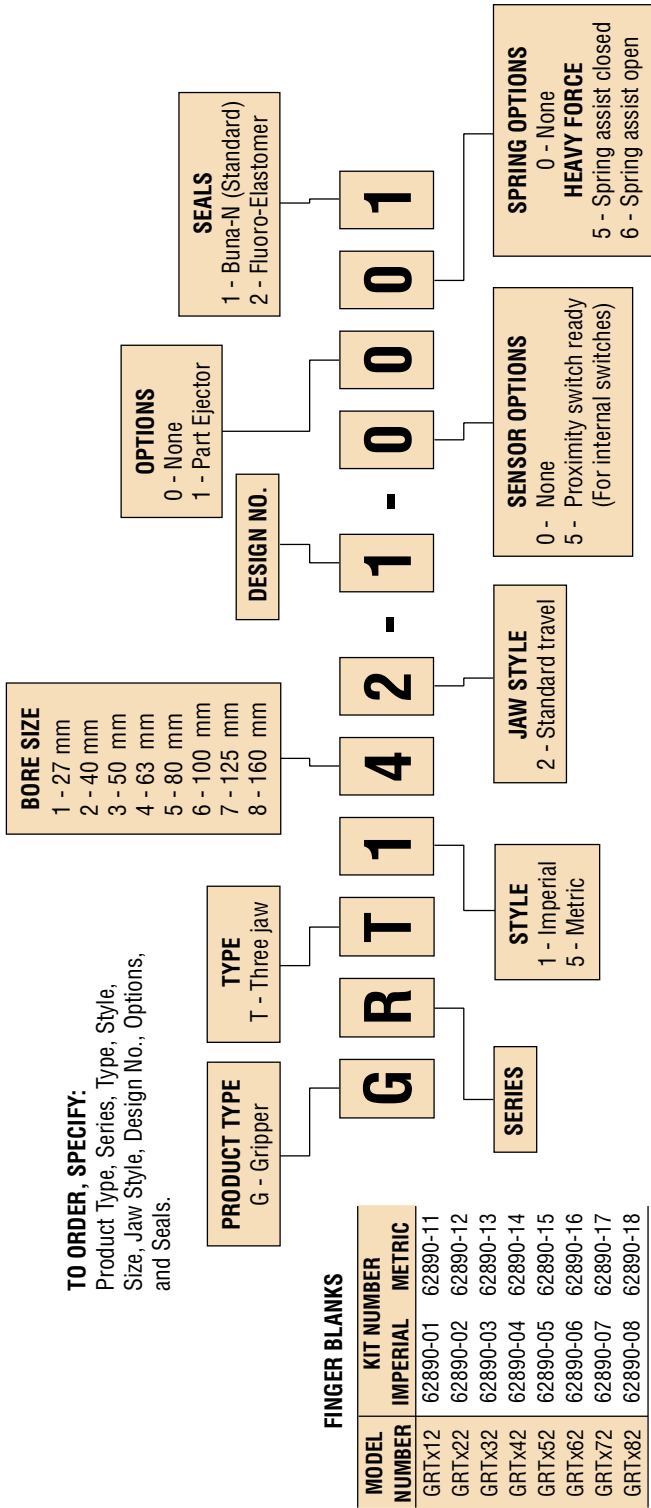

FINGER BLANKS

MODEL NUMBER	KIT NUMBER	IMPERIAL	METRIC
GRTx12	62890-01	62890-11	
GRTx22	62890-02	62890-12	
GRTx32	62890-03	62890-13	
GRTx42	62890-04	62890-14	
GRTx52	62890-05	62890-15	
GRTx62	62890-06	62890-16	
GRTx72	62890-07	62890-17	
GRTx82	62890-08	62890-18	

INTERNAL PROXIMITY SWITCHES

GRIPPER SIZE	SWITCH DESCRIPTION	PART NO.
GRTx1, 2, 3, 4, & 5	4 mm Round NPN (Sink)	18430-001-02
	4 mm Round PNP (Source)	18430-002-02
GRTx6, 7, & 8	8 mm Threaded NPN (Sink)	51422-005-02
	8 mm Threaded PNP (Source)	51422-006-02

INTERNAL PROXIMITY SWITCH TARGET KITS

DIRECTION	GRTx1x	GRTx2x	GRTx3x	GRTx4x	GRTx5x	GRTx6x	GRTx7x	GRTx8x
JAWS OPENING	62805-00	62805-01	62805-02	62805-02	62805-02	62805-03	62805-04	62805-04
JAWS CLOSING	62806-00	62806-01	62806-01	62806-02	62806-02	62806-03	62806-04	62806-05

Kit includes: 1 Proximity Target, 1 Proximity Adjustment Screw, 2 Target Adjustment Screws

EXTERNAL PROXIMITY SWITCHES

GRIPPER SIZE	SWITCH DESCRIPTION	PART NO.
GRTx1, 2, 3, 4, & 5	8 mm Threaded NPN (Sink)	51422-005-02
	8 mm Threaded PNP (Source)	51422-006-02
GRTx6, 7, & 8	12 mm Threaded NPN (Sink)	15561-001
	12 mm Threaded PNP (Source)	15561-002
	12 mm Threaded AC 20-250 VAC	15561-003

EXTERNAL PROXIMITY SWITCH MOUNTING BRACKETS

GRTx1x	GRTx2x	GRTx3x	GRTx4x	GRTx5x	GRTx6x	GRTx7x	GRTx8x
61552-01	61552-02	61552-03	61552-04	61552-05	61552-06	61552-07	61552-08



Options may affect unit length. See unit dimension and options pages for adders.



UNIQUE GRIPPERS ARE AVAILABLE. SEE PAGES 4-139 TO 4-164.

ENGINEERING DATA: SERIES GRT GRIPPERS

SPECIFICATIONS	SERIES GRT
OPERATING PRESSURE	
STANDARD UNIT	30 psi min to 100 psi max [2 bar min to 7 bar max] air
SPRING ASSIST UNIT	60 psi min to 100 psi max [4 bar min to 7 bar max] air
OPERATING TEMPERATURE	-20° to +180°F [-28° to +82°C]
RATED LIFE	10 million cycles minimum with standard seals (including spring assist units) 7.5 million cycles minimum for part ejector springs
GRIP REPEATABILITY	Within ±0.002 in [±0.05 mm] of original centered position
CYCLE TIME	See table below
LUBRICATION	Factory lubricated for rated life
MAINTENANCE	Field repairable

SIZING AND APPLICATION ASSISTANCE
See PHD Product Sizing Catalog for specific and complete sizing information. Online sizing assistance is available at: www.phdinc.com/apps/sizing

MODEL NO.	TOTAL DIAMETRAL JAW TRAVEL		TOTAL CLOSE GRIP FORCE AT		GRIPPER WEIGHT		CLOSE OR OPEN TIME			GRIP FORCE FACTOR G _F			
			87 psi [6 bar]				87 psi [6 bar]			EXTERNAL GRIP		INTERNAL GRIP	
	in	mm	lb	N	lb	kg	sec.	in ³	cm ³	IMPERIAL	METRIC	IMPERIAL	METRIC
GRTx1x	0.236	6	44	196	0.27	0.12	.09	0.10	1.6	0.52	33	0.57	37
GRTx2x	0.315	8	112	499	0.59	0.27	.03	0.30	5	1.29	83	1.43	93
GRTx3x	0.472	12	168	747	0.95	0.43	.04	0.72	12	1.93	125	2.10	136
GRTx4x	0.630	16	218	971	1.75	0.80	.06	1.41	23	2.51	162	2.68	173
GRTx5x	0.787	20	378	1683	2.82	1.28	.07	3.00	49	4.35	281	4.61	297
GRTx6x	1.024	26	569	2531	5.1	2.32	.15	5.63	92	6.54	422	6.99	451
GRTx7x	1.260	32	880	3912	8.75	3.98	.30	10.75	176	10.11	652	10.67	688
GRTx8x	1.575	40	1452	6459	15.5	7.05	.40	21.92	359	16.69	1077	17.52	1131

Minimum Operating Pressure is 30 psi [2 bar] for standard unit and 60 psi [4 bar] for spring assist unit.

HEAVY SPRING

MODEL NO.	S _F SPRING GRIP FORCE		SPRING ASSIST GRIPPER WEIGHT		CLOSE OR OPEN TIME			TOOLING LENGTH		TOOLING WEIGHT			
	MINIMUM		MAXIMUM		WITH SPRING		AGAINST SPRING	ONLY	MAXIMUM		MAX. PER JAW		
	lb	N	lb	N	lb	kg	SPRING	SPRING	ONLY	in	mm	lb	kg
GRTx1x	9	40	18	80	0.34	0.15	.08	.14	.14	1.5	40	0.17	0.08
GRTx2x	14	62	52	231	0.74	0.34	.02	.05	.04	1.97	50	0.30	0.14
GRTx3x	28	125	82	365	1.18	0.54	.04	.10	.10	2.56	65	0.72	0.33
GRTx4x	49	218	110	498	2.15	0.98	.05	.12	.10	2.95	75	1.25	0.57
GRTx5x	118	525	232	1032	3.92	1.78	.08	.16	.12	3.94	100	2.65	1.20
GRTx6x	193	858	341	1517	6.99	3.17	.11	.21	.15	4.92	125	4.50	2.05
GRTx7x	263	1170	498	2215	11.1	5.04	.15	.36	.24	5.91	150	8.80	4.00
GRTx8x	324	1441	591	2629	20.6	9.34	.27	.48	.40	7.87	200	16.00	7.27

Spring grip force (S_F) varies with spring compression. The minimum spring grip force values occur with the spring at least compression (jaws fully closed on spring close units and fully open on spring open units). The maximum spring grip force values occur with the spring at most compression (jaws fully open on spring close units and fully closed on spring open units).

TOOLING LENGTH FACTOR

Tooling should be designed so that the grip point is as close to the body surface as possible. When the grip point moves away, jaw friction increases, which decreases grip force. The G_F information given above is for zero tooling length (body surface). The graph shows how force decreases as the grip point moves away from the body surface.

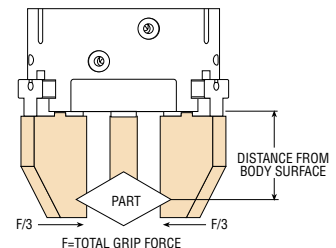

GRIP FORCE CALCULATION EQUATIONS:

IMPERIAL:

$$\text{TOTAL GRIP FORCE [lb]} = (\text{Pressure [psi]} \times G_F) \times \text{Tooling Length Factor}$$

$$\text{TOTAL GRIP FORCE WITH SPRINGS [lb]} = ((\text{Pressure [psi]} \times G_F) \pm S_F \text{ [lb]}) \times \text{Tooling Length Factor}$$

METRIC:

$$\text{TOTAL GRIP FORCE [N]} = (\text{Pressure [bar]} \times G_F) \times \text{Tooling Length Factor}$$

$$\text{TOTAL GRIP FORCE WITH SPRINGS [N]} = ((\text{Pressure [bar]} \times G_F) \pm S_F \text{ [N]}) \times \text{Tooling Length Factor}$$

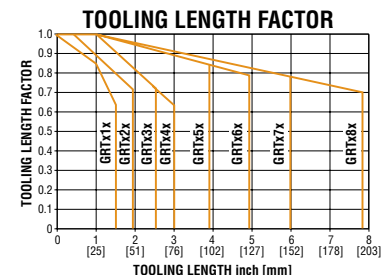

DIMENSIONS: SERIES GRT GRIPPERS

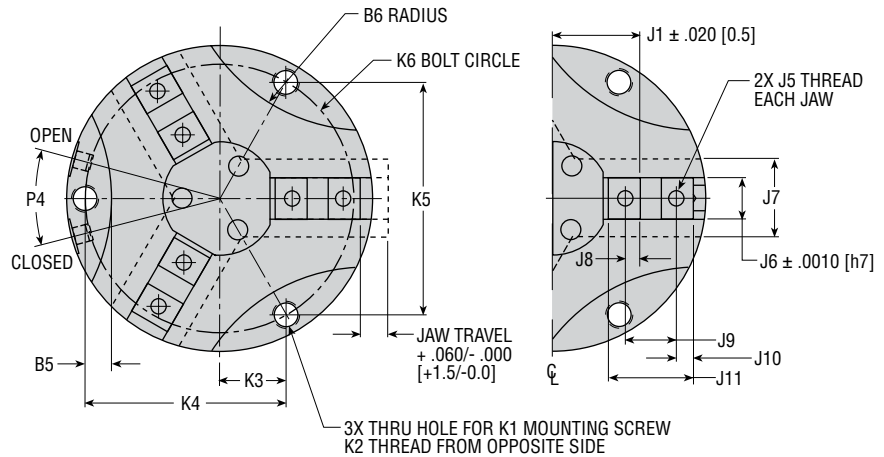
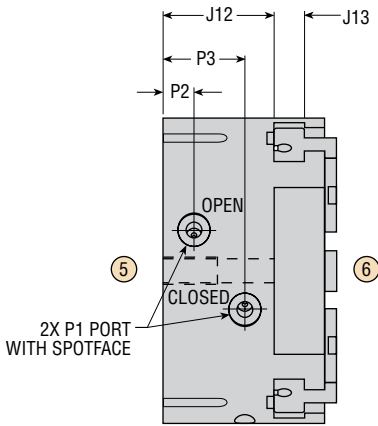
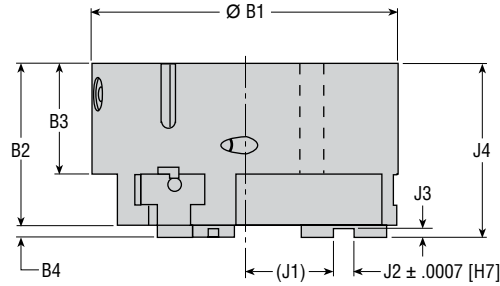
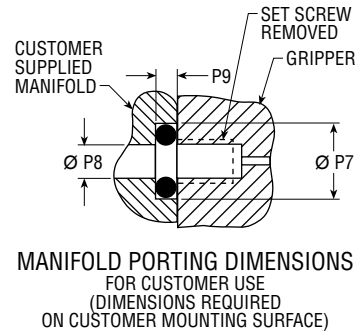
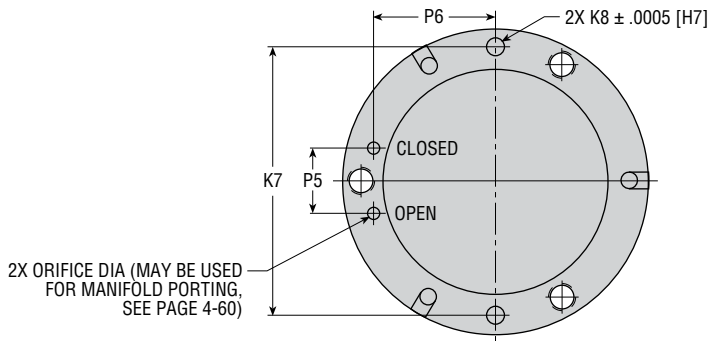

- NOTES:**
 1) SPRING ASSIST OPTION AFFECTS UNIT DIMENSIONS. SEE PAGE 4-56 FOR INFORMATION.
 2) CIRCLED NUMBERS INDICATE POSITION.

DIMENSIONS: SERIES GRT GRIPPERS

LETTER DIM	MODEL NUMBER															
	GRTx1x		GRTx2x		GRTx3x		GRTx4x		GRTx5x		GRTx6x		GRTx7x		GRTx8x	
	in	mm	in	mm	in	mm	in	mm	in	mm	in	mm	in	mm	in	mm
JAW TRAVEL	.118	3.0	.157	4.0	.236	6.0	.315	8.0	.394	10.0	.512	13.0	.630	16.0	.787	20.0
B1	1.850	47.0	2.441	62.0	2.835	72.0	3.543	90.0	4.173	106.0	5.275	134.0	6.339	161.0	7.953	202.0
B2	1.004	25.5	1.279	32.5	1.575	40.0	1.870	47.5	2.205	56.0	2.559	65.0	2.992	76.0	3.563	90.5
B3	.748	19.0	.905	23.0	1.103	28.0	1.279	32.5	1.496	38.0	1.732	44.0	1.968	50.0	2.303	58.5
B4	.615	15.5	.748	19.0	.886	22.5	1.084	27.5	1.279	32.5	1.496	38.0	1.732	44.0	2.117	54.0
B5	.465	11.8	.562	14.3	.688	17.5	.833	21.1	1.004	25.5	1.205	30.7	1.488	37.7	1.817	46.1
B6	.315	8.0	.394	10.0	.492	12.5	.599	15.2	.725	18.4	.886	22.5	1.084	27.5	1.311	33.3
J1 CLOSED	.165	4.2	.207	5.3	.244	6.2	.295	7.5	.354	9.0	.424	10.8	.500	12.7	.583	14.8
J2	.642	16.3	.787	20.0	.886	22.5	1.024	26.0	1.260	32.0	1.476	37.5	1.831	46.5	2.206	56.0
J3	.0787	2.0	.098	2.5	.120	3.0	.149	3.8	.184	4.7	.225	5.7	.276	7.0	.338	8.6
J4	.039	1.0	.049	1.2	.059	1.5	.070	1.8	.084	2.1	.100	2.5	.118	3.0	.144	3.7
J5	.061	1.5	.076	1.9	.092	2.3	.109	2.8	.130	3.3	.156	4.0	.184	4.7	.221	5.6
J6	.3146	8.0	.3927	10.0	.4714	12.0	.5502	14.0	.6290	16.0	.7077	18.0	.7864	20.0	.8652	22.0
J7	.561	14.2	.670	17.0	.709	18.0	.906	23.0	1.063	27.0	1.260	32.0	1.575	40.0	1.890	48.0
J8	.108	2.74	.138	3.5	.157	4.0	.177	4.5	.216	5.5	.275	7.0	.335	8.5	.413	10.5
J9	.295	7.5	.433	11.0	.472	12.0	.590	15.0	.669	17.0	.865	22.0	.965	25.0	1.220	31.0
J10	.119	3.0	.157	4.0	.177	4.5	.197	5.0	.216	5.5	.276	7.0	.334	8.5	.413	10.5
J11	.533	13.5	.748	19.0	.827	21.0	.984	25.0	1.102	28.0	1.418	36.0	1.653	42.0	2.047	52.0
J12	.667	16.9	.905	23.0	1.103	28.0	1.279	32.5	1.496	38.0	1.732	44.0	1.968	50.0	2.303	58.5
J13	.177	4.5	.216	5.5	.276	7.0	.354	9.0	.433	11.0	.512	13.0	.630	16.0	.787	20.0
K1	#5	M3	#8	M4	#10	M5	#14	M6	1/4	M6	5/16	M8	3/8	M10	1/2	M12
K2	8-32	M4x0.7	10-32	M5x0.8	1/4-20	M6x1.0	5/16-18	M8x1.25	5/16-18	M8x1.25	3/8-16	M10x1.5	3/8-16	M10x1.5	1/2-13	M12x1.75
	x.394 DP	x10.0 DP	x.375 DP	x9.5 DP	x.500 DP	x12.0 DP	x.625 DP	x16.0 DP	x.625 DP	x16.0 DP	x.750 DP	x19.0 DP	x.750 DP	x19.0 DP	x1.00 DP	x25.5 DP
K3	.374	9.50	.527	13.39	.620	15.75	.778	19.76	.945	24.00	1.181	30.00	1.447	36.75	1.821	46.25
K4	1.122	28.50	1.580	40.13	1.860	47.24	2.333	59.26	2.834	71.98	3.543	89.99	4.340	110.24	5.463	138.76
K5	1.296	32.92	1.824	46.33	2.148	54.56	2.693	68.40	3.273	83.13	4.091	103.91	5.012	127.30	6.308	160.22
K6	1.496	38.0	2.106	53.5	2.480	63.0	3.110	79.0	3.779	96.0	4.724	120.0	5.787	147.0	7.283	185.0
K7	1.496	38.0	2.106	53.5	2.480	63.0	3.110	79.0	3.779	96.0	4.724	120.0	5.787	147.0	7.283	185.0
K8	.1268	3.0	.1580	4.0	.1973	5.0	.2367	6.0	.2837	7.0	.338	8.0	.402	10.0	.479	12.0
	x.237 DP	x6.0 DP	.315 DP	8.0 DP	.394 DP	10.0 DP	.479 DP	12.0 DP	.562 DP	14.0 DP	.650 DP	16.0 DP	.737 DP	18.0 DP	.825 DP	20.0 DP
P1	10-32	M5x0.8	10-32	M5x0.8	10-32	M5x0.8	10-32	M5x0.8	1/8 NPT	1/8 BSP	1/8 NPT	1/8 BSP	1/8 NPT	1/8 BSP	1/8 NPT	1/8 BSP
P2	.231	5.9	.256	6.5	.295	7.5	.355	9.0	.433	11.0	.512	13.0	.630	16.0	.787	20.0
P3	.492	12.5	.669	17.0	.827	21.0	.946	24.0	1.043	26.5	1.239	31.0	1.496	38.0	1.791	45.5
P4	39°	39°	26°	26°	30°	30°	30°	30°	30°	30°	30°	30°	30°	30°	30°	30°
P5	.484	12.3	.551	14.0	.630	16.0	.768	19.5	.945	24.0	1.181	30.0	1.457	37.0	1.850	47.0
P6	.670	17.0	.984	25.0	1.181	30.0	1.437	36.5	1.772	45.0	2.205	56.0	2.717	69.0	3.465	88.0
P7	.276	7.0	.276	7.0	.276	7.0	.276	7.0	.315	8.0	.354	9.0	.354	9.0	.354	9.0
P8	.098	2.5	.098	2.5	.098	2.5	.098	2.5	.138	3.5	.177	4.5	.177	4.5	.177	4.5
P9	.048	1.2	.048	1.2	.048	1.2	.048	1.2	.048	1.2	.048	1.2	.048	1.2	.048	1.2



All dimensions are reference only unless specifically toleranced.

OPTIONS: SERIES GRT GRIPPERS

5 & 6 HEAVY FORCE SPRING ASSIST

Springs can maintain spring grip force if air pressure is lost or increase grip force in one specific direction when used with air pressure. Spring life in excess of 10 million cycles can be expected. For minimum operating pressures and spring grip forces, see table on page 4-53.

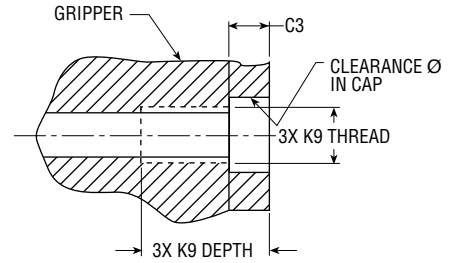
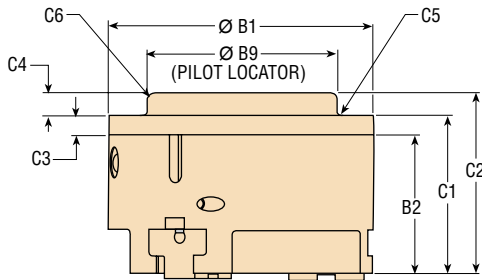
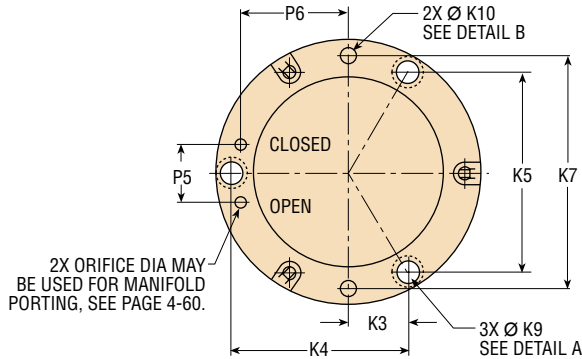

**K9 MOUNTING DIMENSIONS
DETAIL A**

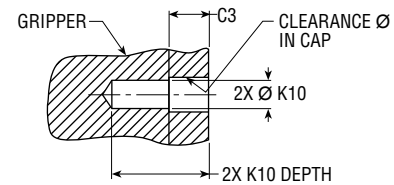

**K10 MOUNTING PIN DIMENSIONS
DETAIL B**

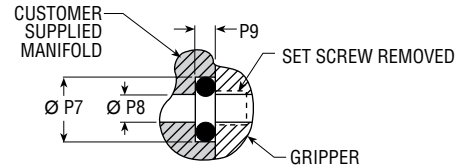

**MANIFOLD PORTING DIMENSIONS
FOR CUSTOMER USE
(DIMENSIONS REQUIRED
ON CUSTOMER MOUNTING SURFACE)**

LETTER DIM	MODEL NUMBER															
	GRTx1x		GRTx2x		GRTx3x		GRTx4x		GRTx5x		GRTx6x		GRTx7x		GRTx8x	
Ø B1	in	mm	in	mm	in	mm	in	mm	in	mm	in	mm	in	mm	in	mm
B2	1.850	47.0	2.441	62.0	2.835	72.0	3.543	90.0	4.173	106.0	5.275	134.0	6.339	161.0	7.953	202.0
Ø B9 MAX	1.004	25.5	1.279	32.5	1.575	40.0	1.870	47.5	2.205	56.0	2.559	65.0	2.992	76.0	3.563	90.5
Ø B9 MIN	1.0650	27.1	1.6535	42.00	2.0079	51.00	2.5591	65.00	3.2283	82.00	4.0157	102.00	5.0394	128.00	6.2992	160.00
C1	1.0610	26.9	1.6490	41.89	2.0034	50.89	2.5526	64.83	3.2218	81.83	4.0092	101.83	5.0329	127.83	6.2927	159.83
C2	1.240	31.5	1.515	38.5	1.811	46.0	2.146	54.5	2.559	65.0	2.913	74.0	3.425	87.0	4.075	103.5
C3	1.358	34.5	1.732	44.0	2.106	54.0	2.442	62.0	2.992	76.0	3.524	90.0	4.173	106.0	5.059	128.5
C4	.236	6.0	.236	6.0	.236	6.0	.276	7.0	.354	9.0	.354	9.0	.433	11.0	.512	13.0
C5	.118	3.0	.217	6.0	.295	8.0	.296	8.0	.433	11.0	.611	16.0	.748	19.0	.984	25.0
C6	.030	.8	.080	2	.080	2	.110	2.8	.110	2.8	.220	5.6	.220	5.6	.220	5.6
K3	.374	9.5	.527	13.39	.620	15.75	.778	19.76	.945	24.0	1.181	30.0	1.447	36.75	1.821	46.25
K4	1.122	28.5	1.580	40.13	1.860	47.24	2.333	59.26	2.834	71.98	3.543	89.99	4.340	110.24	5.463	138.76
K5	1.296	32.9	1.824	46.33	2.148	54.56	2.693	68.40	3.273	83.13	4.091	103.91	5.012	127.30	6.308	160.22
K7	1.496	38.0	2.106	53.5	2.480	63.0	3.110	79.0	3.779	96.0	4.724	120.0	5.787	147.0	7.283	185.0
K9	8-32 x .394 DP	M4 x 0.7 x .394 DP	10-32 x .611 DP	M5 x 0.8 x 16.0 DP	1/4-20 x .736 DP	M6 x 1.0 x 19.0 DP	5/16-18 x .901 DP	M8 x 1.25 x 23.0 DP	5/16-18 x .979 DP	M8 x 1.25 x 25.0 DP	3/8-16 x 1.104 DP	M10 x 1.5 x 28.0 DP	3/8-16 x 1.183 DP	M10 x 1.5 x 30.0 DP	1/2-13 x 1.512 DP	M12 x 1.75 x 38.0 DP
K10	0.1268 x .315 DP	3.0 x .315 DP	.1580 x .551 DP	4.0 x 14.0 DP	.1580 x .551 DP	4.0 x 14.0 DP	.1973 x .670 DP	5.0 x 26.0 DP	.1973 x .748 DP	5.0 x 19.0 DP	.2367 x .824 DP	6.0 x 21.0 DP	.2367 x .903 DP	6.0 x 23.0 DP	.3155 x 1.132 DP	10.0 x 29.0 DP
P5	.484	12.3	.551	14.0	.630	16.0	.768	19.5	.945	24.0	1.181	30.0	1.457	37.0	1.850	47.0
P6	.670	17.0	.984	25.0	1.181	30.0	1.437	36.5	1.772	45.0	2.205	56.0	2.717	69.0	3.465	88.0
Ø P7	.276	7.0	.276	7.0	.276	7.0	.315	8.0	.315	8.0	.354	9.0	.354	9.0	.354	9.0
Ø P8	.098	2.5	.098	2.5	.098	2.5	.138	3.5	.138	3.5	.177	4.5	.177	4.5	.177	4.5
P9	.048	1.2	.048	1.2	.048	1.2	.048	1.2	.048	1.2	.048	1.2	.048	1.2	.048	1.2

All dimensions are reference only unless specifically toleranced.

www.phdinc.com/grt • (800) 624-8511

OPTIONS: SERIES GRT GRIPPERS

5 PROXIMITY SWITCH READY-INTERNAL

This option equips the gripper with sleeves to provide for the mounting of up to three round proximity switches. Target Kits and Proximity Switches are ordered separately. See Switches and Sensors section for complete switch specifications. The

adjustable positioning target assembly is protected under U.S. Patent No. 6019409.

LETTER DIM	MODEL NUMBER															
	GRTx1x		GRTx2x		GRTx3x		GRTx4x		GRTx5x		GRTx6x		GRTx7x		GRTx8x	
	in	mm	in	mm	in	mm	in	mm	in	mm	in	mm	in	mm	in	mm
PS1	4mm ROUND		4mm ROUND		4mm ROUND		4mm ROUND		4mm ROUND		8mm THREADED		8mm THREADED		8mm THREADED	
PS2	.020	.5	.020	.5	.020	.5	.020	.5	.020	.5	.030	.76	.030	.76	.030	.76
PS3	.388	9.86	.527	13.37	.620	15.75	.778	19.75	.945	24.0	1.181	30.0	1.447	36.75	1.821	46.25
PS4	.775	19.69	1.053	26.75	1.240	31.5	1.555	39.5	1.890	48.0	2.362	60.0	2.894	73.5	3.642	92.5
PS5	1.342	34.09	1.824	46.33	2.148	54.55	2.693	68.41	3.273	83.13	4.091	103.91	5.012	127.30	6.307	160.20
PS6	1.21	30.7	1.42	36.0	1.22	31.0	1.18	30.0	1.18	30.0	1.18	30.0	.94	24.0	.98	25.0
PS7	1.21	30.7	1.42	36.0	1.22	31.0	1.04	26.5	.83	21.0	1.18	30.0	.94	24.0	.61	15.5
PS9	.555	14.1	.773	19.6	.971	24.7	1.147	29.1	1.364	34.6	1.524	38.7	1.760	44.7	2.095	53.2
PS10	.030	.75	.030	.75	.030	.75	.030	.75	.060	1.5	.167	4.25	.276	7.0	.404	10.25
PS11	.157	4.0	.157	4.0	.157	4.0	.157	4.0	.157	4.0	.315	8.0	.315	8.0	.315	8.0

SENSING DIRECTION	TARGET KIT NUMBER							
	GRTx1x	GRTx2x	GRTx3x	GRTx4x	GRTx5x	GRTx6x	GRTx7x	GRTx8x
JAWS OPENING	62805-00	62805-01	62805-02	62805-02	62805-02	62805-03	62805-04	62805-04
JAWS CLOSING	62806-00	62806-01	62806-01	62806-02	62806-03	62806-04	62806-05	62806-05

EACH KIT WILL MOUNT ONE SWITCH.

KIT INCLUDES: 1 PROXIMITY TARGET, 1 PROXIMITY ADJUSTMENT HEX, 2 TARGET ADJUSTMENT SCREWS

4 mm ROUND INDUCTIVE PROXIMITY SWITCHES

PART NUMBER	DESCRIPTION
18430-001-02	NPN (Sink) 2 meter cable
18430-002-02	PNP (Source) 2 meter cable

8 mm THREADED INDUCTIVE PROXIMITY SWITCHES

PART NUMBER	DESCRIPTION
51422-005-02	NPN (Sink) 2 meter cable
51422-006-02	PNP (Source) 2 meter cable

- NOTES: 1) (PS10) THE PROX TARGET MAY EXTEND OUT OF THE JAW WHEN THE JAWS CLOSE. TARGET IS ADJUSTED TO SENSE LESS THAN .039 [1 mm] MOVEMENT FROM THE FULL CLOSED POSITION
 2) JAWS SHOWN IN FULL OPEN POSITION
 3) INSTALLATION OF SWITCHES ON A MOUNTED UNIT MAY NOT BE POSSIBLE WITHOUT PROPER CLEARANCES IN FIXTURE

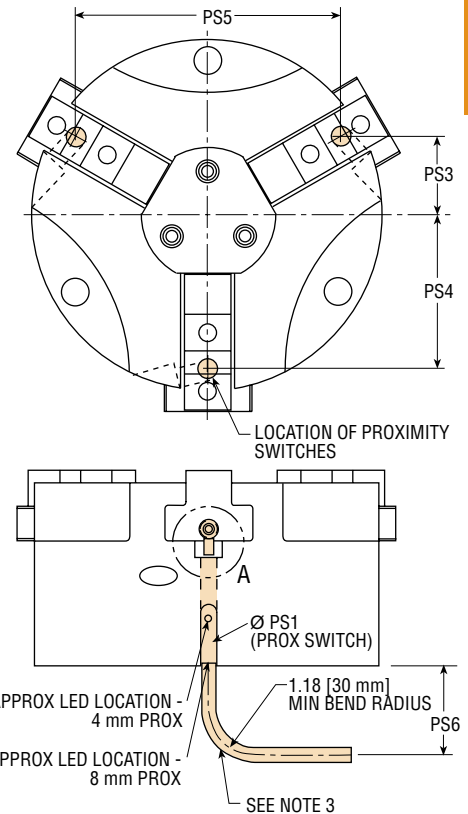
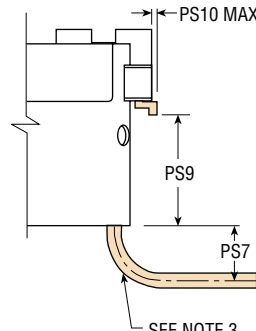
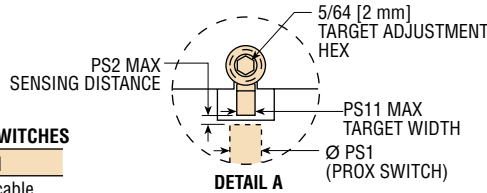

GRT

All dimensions are reference only unless specifically toleranced.

www.phdinc.com/grt • (800) 624-8511

OPTIONS: SERIES GRT GRIPPERS

1

PART EJECTOR

This option equips the gripper with a spring actuated part ejector. When grip force is removed, the part ejector can push the part against a positive stop. This allows accurate part location and isolates forces due to location within the gripper mechanism, protecting the rest of the automation device. Spring life in excess of 7.5 million cycles can be expected.

MODEL NO.	PART EJECTOR TOTAL SPRING FORCE	
	lb	N
GRTx1x	3 - 5	13 - 22
GRTx2x	4.5 - 8.4	20 - 37
GRTx3x	7.5 - 11	33 - 51
GRTx4x	11 - 18	51 - 80
GRTx5x	20 - 28	88 - 124
GRTx6x	27 - 38	121 - 167
GRTx7x	35 - 56	157 - 248
GRTx8x	74 - 96	330 - 427

3X Ø EJ8 (MAXIMUM FASTENER SIZE WHEN USED WITH CUSTOMER MODIFIED PART EJECTOR PLATE) PHD SUPPLIED SPOTDRILL FOR EASY CUSTOMER MODIFICATION

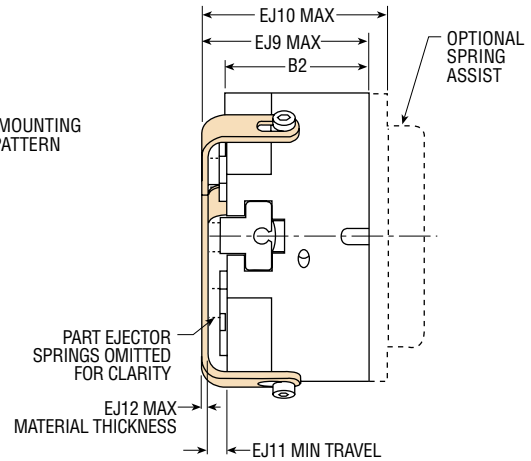
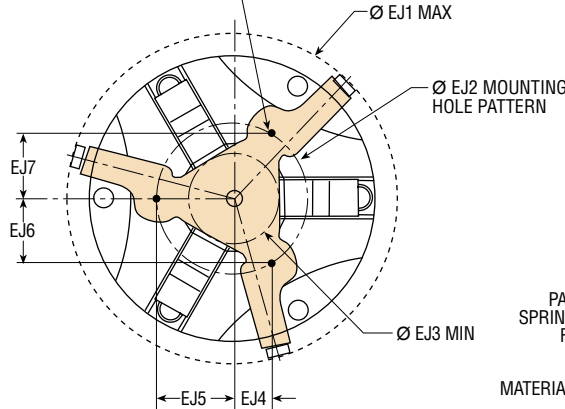
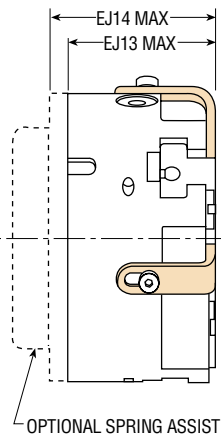

PART EJECTOR COMPRESSED

PART EJECTOR EXTENDED

LETTER DIM	MODEL NUMBER															
	GRTx1x		GRTx2x		GRTx3x		GRTx4x		GRTx5x		GRTx6x		GRTx7x		GRTx8x	
	in	mm	in	mm	in	mm	in	mm	in	mm	in	mm	in	mm	in	mm
B2	1.004	25.5	1.279	32.5	1.575	40.0	1.870	47.5	2.205	56.0	2.559	65.0	2.992	76.0	3.563	90.5
Ø EJ1	2.330	59.2	3.239	82.0	3.633	92.0	4.312	110.0	4.940	125.0	6.083	155.0	7.384	188.0	8.983	228.0
Ø EJ2	N/A	N/A	1.318	33.5	1.510	38.4	1.892	48.0	2.264	57.5	2.784	70.7	3.296	83.7	4.014	102.0
Ø EJ3	.700	17.8	.766	19.5	.872	22.1	1.022	25.9	1.376	34.9	1.572	39.9	1.924	48.8	2.458	62.4
EJ4	N/A	N/A	.330	8.0	.378	10.0	.473	12.0	.566	14.0	.696	18.0	.824	21.0	1.004	26.0
EJ5	N/A	N/A	.659	17.0	.755	19.0	.946	24.0	1.132	29.0	1.392	35.0	1.648	42.0	2.007	51.0
EJ6	N/A	N/A	.571	14.0	.654	17.0	.819	21.0	.980	25.0	1.206	31.0	1.427	36.0	1.738	44.0
EJ7	N/A	N/A	.571	14.0	.654	17.0	.819	21.0	.980	25.0	1.206	31.0	1.427	36.0	1.738	44.0
Ø EJ8	N/A	N/A	#2	M2	#6	M3	#8	M4	#10	M5	5/16	M8	3/8	M10	1/2	M12
EJ9	1.126	28.6	1.552	39.4	1.966	49.9	2.275	57.8	2.614	66.4	3.061	77.7	3.572	90.7	4.221	107.2
EJ10	1.362	34.6	1.788	45.4	2.202	56.0	2.551	64.8	2.960	75.2	3.415	86.7	4.006	101.8	4.734	120.3
EJ11	.062	1.6	.121	3.0	.239	6.0	.239	6.0	.239	6.0	.318	8.0	.396	10.1	.474	12.1
EJ12	.062	1.6	.113	2.9	.113	2.9	.128	3.3	.128	3.3	.143	3.7	.143	3.7	.143	3.7
EJ13	1.061	26.9	1.404	35.7	1.700	43.2	2.010	51.1	2.345	59.6	2.714	68.9	3.147	79.9	3.718	94.4
EJ14	1.297	32.9	1.533	38.9	1.829	46.4	2.164	55.0	2.577	65.4	2.931	74.4	3.443	87.4	4.093	103.9

ACCESSORIES: SERIES GRT GRIPPERS

PROXIMITY SWITCHES - EXTERNAL

This accessory provides for the external mounting of round metal sensing proximity switches. Up to six switches may be mounted using multiple brackets. The user is required to design

and mount targets for the switch to sense. Proximity Switches are ordered separately. See Switches and Sensors section for complete switch specifications.

LETTER DIM	MODEL NUMBER															
	GRTx1x		GRTx2x		GRTx3x		GRTx4x		GRTx5x		GRTx6x		GRTx7x		GRTx8x	
	in	mm	in	mm	in	mm	in	mm	in	mm	in	mm	in	mm	in	mm
EP1	8mm THREADED		8mm THREADED		8mm THREADED		8mm THREADED		8mm THREADED		12mm THREADED		12mm THREADED		12mm THREADED	
EP2	1.772	45.0	1.772	45.0	1.772	45.0	1.772	45.0	1.772	45.0	2.362	60.0	2.362	60.0	2.362	60.0
EP3	.157	4.0	.157	4.0	.157	4.0	.157	4.0	.157	4.0	.157	4.0	.157	4.0	.157	4.0
EP4	.512	13.0	.512	13.0	.512	13.0	.512	13.0	.512	13.0	.669	17.0	.669	17.0	.669	17.0
EP5	.748	19.0	.905	23.0	1.103	28.0	1.279	32.5	1.496	38.0	1.732	44.0	1.968	50.0	2.303	58.5
EP6	.925	23.5	1.221	31.0	1.418	36.0	1.772	45.0	2.087	53.0	2.638	67.0	3.170	80.5	3.977	101.0
EP7	.377	9.6	.413	10.5	.419	10.6	.403	10.25	.443	11.25	.512	13.0	.492	12.5	.515	13.1
EP8	.702	17.8	.738	18.75	.744	18.9	.728	18.5	.768	19.5	.935	23.75	.915	23.25	.938	23.8
EP9	.060	1.5	.105	2.7	.105	2.7	.105	2.7	.105	2.7	.105	2.7	.105	2.7	.105	2.7
EP10	.483	12.3	.693	17.6	.817	20.8	.983	25.0	1.077	27.4	1.433	36.4	1.522	38.7	1.944	49.4
EP11	.648	16.5	.689	17.5	.688	17.5	.836	21.2	.968	24.6	1.207	30.7	1.401	35.6	1.723	43.8
EP12	30°	30°	25°	25°	22.0°	22.0°	22.5°	22.5°	22.5°	22.5°	22.5°	22.5°	22.5°	22.5°	22.5°	22.5°

MOUNTING BRACKETS

PART NUMBER	BRACKET NUMBER
GRTx12	61552-01
GRTx22	61552-02
GRTx32	61552-03
GRTx42	61552-04
GRTx52	61552-05
GRTx62	61552-06
GRTx72	61552-07
GRTx82	61552-08

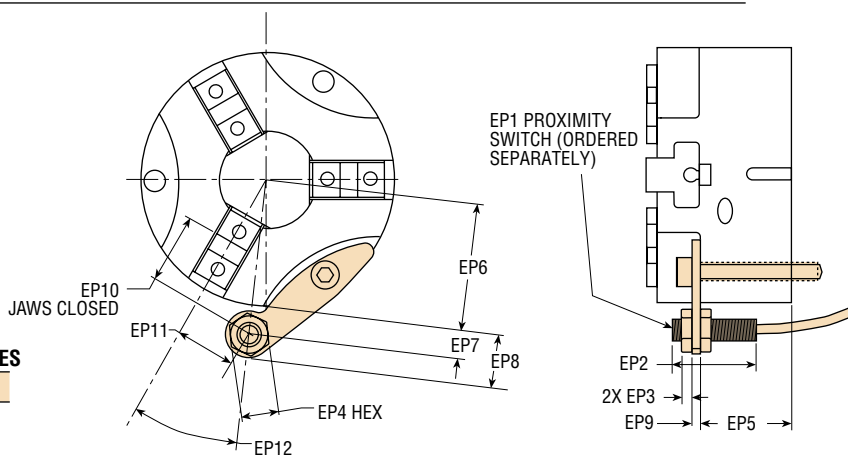

8 mm THREADED INDUCTIVE PROXIMITY SWITCHES

PART NUMBER	DESCRIPTION
51422-005-02	NPN (Sink) 2 meter cable
51422-006-02	PNP (Source) 2 meter cable

12 mm THREADED INDUCTIVE PROXIMITY SWITCHES

PART NUMBER	DESCRIPTION
15561-001	NPN (Sink) 3 meter cable
15561-002	PNP (Source) 3 meter cable
15561-003	VAC Solid State, 3 meter cable

GRIPPER MOUNTING KIT

Gripper mounting kits are available. The kit includes three socket head cap screws. Part ejector option does not affect mounting kits listed below.

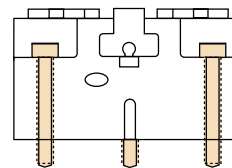

STANDARD UNIT	MODEL NUMBER															
	GRT112	GRT512	GRT122	GRT522	GRT132	GRT532	GRT142	GRT542	GRT152	GRT552	GRT162	GRT562	GRT172	GRT572	GRT182	GRT582
KIT NUMBER	61620-01	62813-01	61620-02	62813-02	61620-03	62813-03	61620-04	62813-04	61620-05	62813-05	61620-06	62813-06	61620-07	62813-07	61620-08	62813-08
FASTENER (SHCS)	5-40 x 1-1/4	M3 x 0.5 x25	8-32 x 1-1/4	M4 x 0.7 x30	10-24 x 1-1/2	M5 x 0.8 x40	1/4-20 x 1-3/4	M6 x 1.0 x45	1/4-20 x 2	M6 x 1.0 x50	5/16-18 x 2-1/4	M8 x 1.25 x50	5/16-18 x 2-1/2	M8 x 1.25 x65	3/8-16 x 3	M10 x 1.5 x80

SPRING ASSIST UNIT	MODEL NUMBER															
	GRT112	GRT512	GRT122	GRT522	GRT132	GRT532	GRT142	GRT542	GRT152	GRT552	GRT162	GRT562	GRT172	GRT572	GRT182	GRT582
KIT NUMBER	64128-01	64129-01	64128-02	64129-02	64128-03	64129-03	64128-04	64129-04	64128-05	64129-05	64128-06	64129-06	64128-07	64129-07	64128-08	64129-08
FASTENER (SHCS)	6-32 x 1-1/4	M3 x 0.5 x30	8-32 x 1-1/2	M4 x 0.7 x35	10-24 x 1-3/4	M5 x 0.8 x45	1/4-20 x 2	M6 x 1.0 x50	1/4-20 x 2-1/2	M6 x 1.0 x60	5/16-18 x 2-3/4	M8 x 1.25 x62	5/16-18 x 3	M8 x 1.25 x75	3/8-16 x 3-1/2	M10 x 1.5 x90

All dimensions are reference only unless specifically tolerated.

www.phdinc.com/grt • (800) 624-8511

ACCESSORIES: SERIES GRT GRIPPERS

FINGER BLANKS

This accessory provides jaw tooling blanks which can easily be machined to meet specific application requirements. Each aluminum blank has key geometry to precisely mate and align with the Series GRT Gripper jaw. One finger blank is supplied per kit.

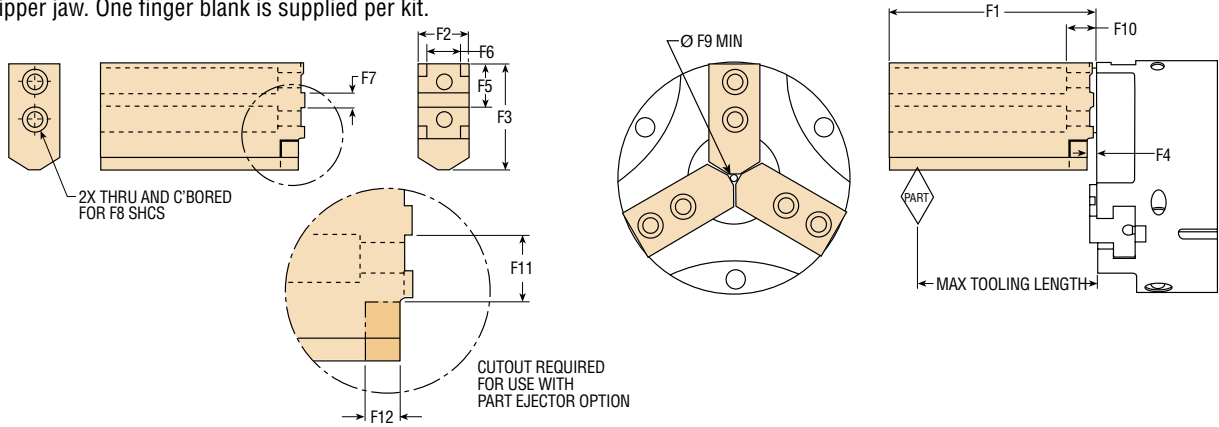

LETTER DIM	MODEL NUMBER															
	GRTx1x		GRTx2x		GRTx3x		GRTx4x		GRTx5x		GRTx6x		GRTx7x		GRTx8x	
	in	mm	in	mm	in	mm	in	mm	in	mm	in	mm	in	mm	in	mm
F1	1.632	41.5	2.165	55.0	2.756	70.0	3.150	80.0	4.331	110.0	5.315	135.0	6.299	160.0	8.465	215.0
F2	.500	12.70	.625	15.88	.625	15.88	.750	19.05	1.000	25.40	1.250	31.75	1.500	38.10	1.750	44.45
F3	.980	24.9	1.260	32.0	1.380	35.1	1.633	41.5	1.938	49.2	2.407	61.1	2.900	73.7	3.442	87.4
F4	.096	2.4	.196	5.0	.157	4.0	.137	3.5	.196	5.0	.157	4.0	.196	5.0	.236	6.0
F5	.375	9.5	.531	13.5	.551	14.0	.679	17.25	.748	19.0	1.023	26.0	1.161	29.5	1.339	34.0
F6	.3156	8.0	.3938	10.0	.3938	10.0	.4725	12.0	.5513	14.0	.6694	17.0	.7875	20.0	.9850	25.0
F7	.0777	2.0	.1570	4.0	.1570	4.0	.2356	6.0	.2357	6.0	.3145	8.0	.3145	8.0	.3932	10.0
F8 SHCS	4-40 x 5/8	M3 x 0.5 x 16.0	8-32 x 1/2	M4 x 0.7 x 12.0	8-32 x 5/8	M4 x 0.7 x 16.0	10-24 x 5/8	M5 x 0.8 x 16.0	1/4-20 x 3/4	M6 x 1.0 x 20.0	5/16-18 x 1	M8 x 1.25 x 25.0	3/8-16 x 1	M10 x 1.5 x 25.0	1/2-13 x 1-1/2	M12 x 1.75 x 40.0
F9	.065	1.65	.065	1.65	.065	1.65	.091	2.30	.091	2.3	.133	3.35	.133	3.35	.157	3.90
F10	.541	13.7	.490	12.4	.523	13.3	.438	11.1	.576	14.6	.694	17.6	.623	15.8	1.048	26.6
F11	.280	7.1	.278	7.0	.319	8.1	.388	9.9	.416	10.6	.535	13.6	.691	17.6	.809	20.5
F12	.110	2.8	.171	4.3	.328	8.3	.362	9.2	.299	7.6	.439	11.2	.480	12.2	.517	13.1

MODEL NUMBER	TOOLING LENGTH		WEIGHT PER FINGER BLANK	
	in	mm	lb	kg
GRTx1x	1.495	38	.059	.027
GRTx2x	1.97	50	.12	.05
GRTx3x	2.56	65	.17	.08
GRTx4x	2.95	75	.29	.13
GRTx5x	3.94	100	.63	.29
GRTx6x	4.92	125	1.25	.57
GRTx7x	5.91	150	2.06	.95
GRTx8x	7.87	200	3.85	1.75

MODEL NUMBER	KIT NUMBER*	
	IMPERIAL	METRIC
GRTx1x	62890-01	62890-11
GRTx2x	62890-02	62890-12
GRTx3x	62890-03	62890-13
GRTx4x	62890-04	62890-14
GRTx5x	62890-05	62890-15
GRTx6x	62890-06	62890-16
GRTx7x	62890-07	62890-17
GRTx8x	62890-08	62890-18

* ONE FINGER BLANK IS SUPPLIED PER KIT. (THREE KITS REQUIRED TO EQUIP EACH GRIPPER).

MANIFOLD SEAL KIT

All Series GRT grippers have manifold porting as standard. Port plugs must first be removed when using this feature. See pages 4-54 and 4-55 for dimensions.

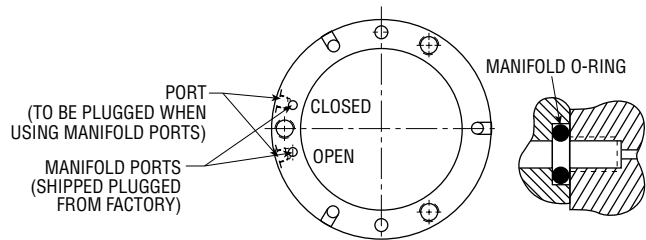

MANIFOLD KIT INCLUDES

- 2 PORT PLUGS
- 2 MANIFOLD O-RING SEALS

	MODEL NUMBER															
	GRT112	GRT512	GRT122	GRT522	GRT132	GRT532	GRT142	GRT542	GRT152	GRT552	GRT162	GRT562	GRT172	GRT572	GRT182	GRT582
KIT NUMBER: (STD SEALS)	61553-01-1	61553-05-1	61553-01-1	61553-05-1	61553-01-1	61553-05-1	61553-02-1	61553-06-1	61553-03-1	61553-07-1	61553-04-1	61553-08-1	61553-04-1	61553-08-1	61553-04-1	61553-08-1
(FLUORO-ELASTOMER SEALS)	61553-01-2	61553-05-2	61553-01-2	61553-05-2	61553-01-2	61553-05-2	61553-02-2	61553-06-2	61553-03-2	61553-07-2	61553-04-2	61553-08-2	61553-04-2	61553-08-2	61553-04-2	61553-08-2
O-RING SIZE	.157 ID x .059 CS	4.0 ID x 1.5 CS	.157 ID x .059 CS	4.0 ID x 1.5 CS	.157 ID x .059 CS	4.0 ID x 1.5 CS	.197 ID x .059 CS	5.0 ID x 1.5 CS	.197 ID x .059 CS	5.0 ID x 1.5 CS	.236 ID x .059 CS	6.0 ID x 1.5 CS	.236 ID x .059 CS	6.0 ID x 1.5 CS	.236 ID x .059 CS	6.0 ID x 1.5 CS