

5300 parallel

**COMPACT SIZE WITH
TWO JAW STYLES**

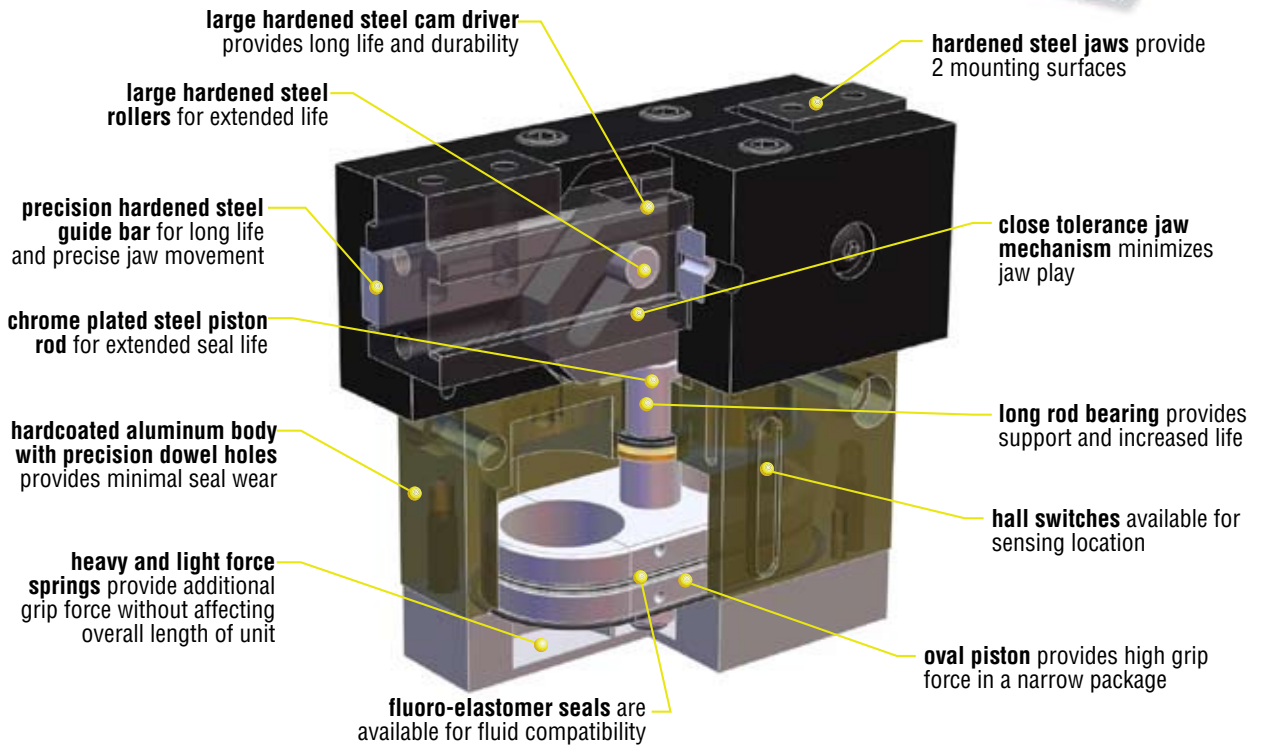

5300 par

Major Benefits

- Spring assist on open or close available in different forces
- High grip force to weight ratio
- Hardened steel jaw driver mechanism
- Close tolerance jaw mechanism minimizes jaw play
- Four sizes available in both imperial and metric versions
- 1-2 day shipping
- 5 million cycles minimum rated life with standard seals (includes spring assist units)

Industry Uses

- Assembly machine builders
- Material handling
- Robotics

ORDERING DATA: SERIES 5300 PARALLEL OVAL GRIPPERS

TO ORDER SPECIFY:

Model, Design No., Options, and Seals.

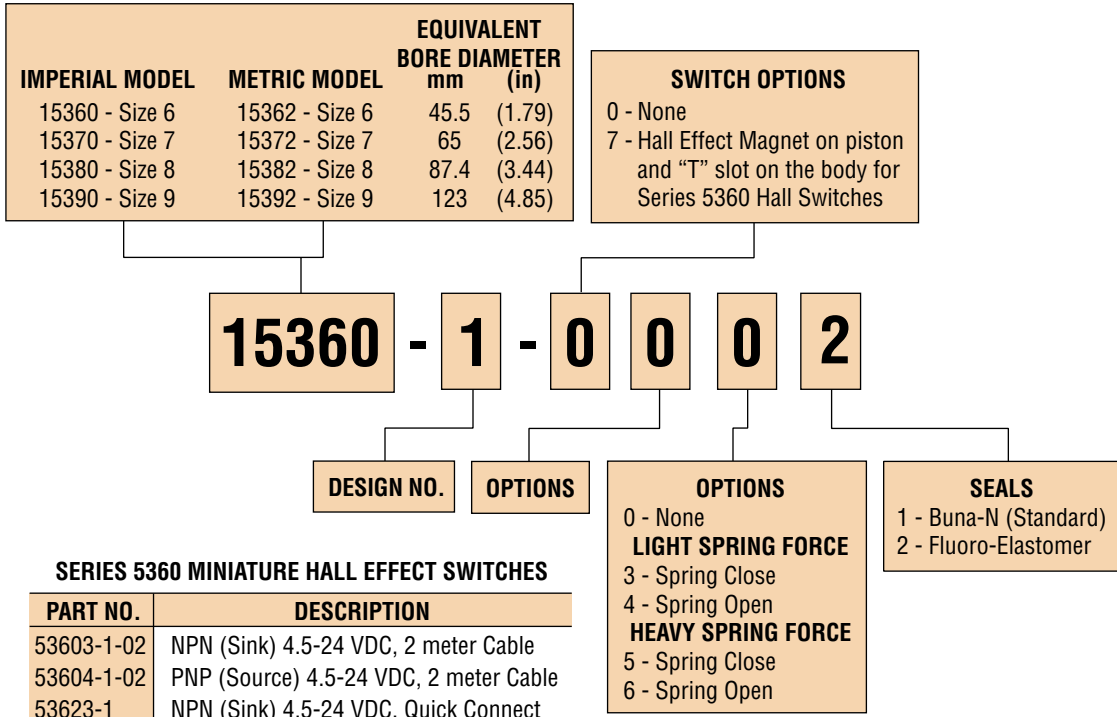

NOTES:

- 1) See Switches and Sensors section for switch information.
- 2) Switches must be ordered separately.



UNIQUE GRIPPERS ARE AVAILABLE.
SEE PAGES 4-139 TO 4-164.

5300 par

ENGINEERING DATA: SERIES 5300 PARALLEL OVAL GRIPPERS

SPECIFICATIONS	SERIES 5300 PARALLEL
OPERATING PRESSURE	
STANDARD UNIT	25 psi min to 150 psi max [1.7 bar min to 10 bar max] air
LIGHT SPRING ASSIST UNIT	40 psi min to 150 psi max [2.8 bar min to 10 bar max] air
HEAVY SPRING ASSIST UNIT	65 psi min to 150 psi max [4.5 bar min to 10 bar max] air
OPERATING TEMPERATURE	-20° to +180°F [-28° to +82°C]
RATED LIFE	5 million cycles minimum with standard seals (including spring assist units)
GRIP REPEATABILITY	Within ±0.002 in [±0.05 mm] of original centered position
LUBRICATION	Factory lubricated for rated life
MAINTENANCE	Field repairable

GRIPPER NO.	DISPLACEMENT		GRIP FORCE FACTOR G_F				SPRING GRIP FORCE S_F			
			EXTERNAL GRIP		INTERNAL GRIP		LIGHT SPRING		HEAVY SPRING	
			IMPERIAL	METRIC	IMPERIAL	METRIC	lb	N	lb	N
1536x	.73	12.0	1.47	95.0	1.60	109.0	27.0	121.0	38.5	172.2
1537x	2.58	42.3	3.00	194.0	3.27	211.0	50.0	223.0	85.0	377.6
1538x	6.09	99.8	5.61	362.0	5.90	381.0	88.0	391.0	145.0	647.0
1539x	16.82	275.6	11.26	726.0	11.75	758.0	159.0	706.0	343.0	1527.0

5300 par

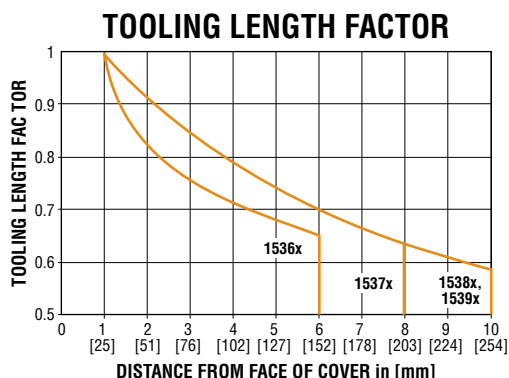

GRIPPER NO.	GRIPPER WEIGHT					
	STANDARD		SPRING ASSIST			
			LIGHT		HEAVY	
lb	kg	lb	kg	lb	kg	
1536x	3.1	1.41	3.2	1.43	3.2	1.44
1537x	7.0	3.18	7.2	3.24	7.2	3.24
1538x	14.0	6.35	14.4	6.53	14.6	6.64
1539x	37.0	16.78	38.7	17.57	39.1	17.73

TOOLING LENGTH FACTOR

Jaw tooling should be designed so that the grip point is as close to the cover surface as possible. As the grip point is moved away from the cover surface, the applied moment causes jaw friction to increase, resulting in reduced effective grip force. The Grip Force Factor (G_F) values given in the table are for zero tooling length (cover surface).

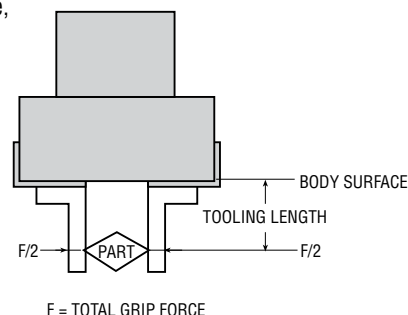

SIZING AND APPLICATION ASSISTANCE

See PHD Product Sizing Catalog for specific and complete sizing information. Online sizing assistance is available at: www.phdinc.com/apps/sizing

GRIP FORCE CALCULATION EQUATIONS:

IMPERIAL:

$$\text{TOTAL GRIP FORCE [lb]} = (\text{Pressure [psi]} \times G_F) \times \text{Tooling Length Factor}$$

$$\text{TOTAL GRIP FORCE WITH SPRINGS [lb]} = ((\text{Pressure [psi]} \times G_F) \pm S_F [\text{lb}]) \times \text{Tooling Length Factor}$$

METRIC:

$$\text{TOTAL GRIP FORCE [N]} = (\text{Pressure [bar]} \times G_F) \times \text{Tooling Length Factor}$$

$$\text{TOTAL GRIP FORCE WITH SPRINGS [N]} = ((\text{Pressure [bar]} \times G_F) \pm S_F [\text{N}]) \times \text{Tooling Length Factor}$$

DIMENSIONS: SERIES 5300 PARALLEL OVAL GRIPPER

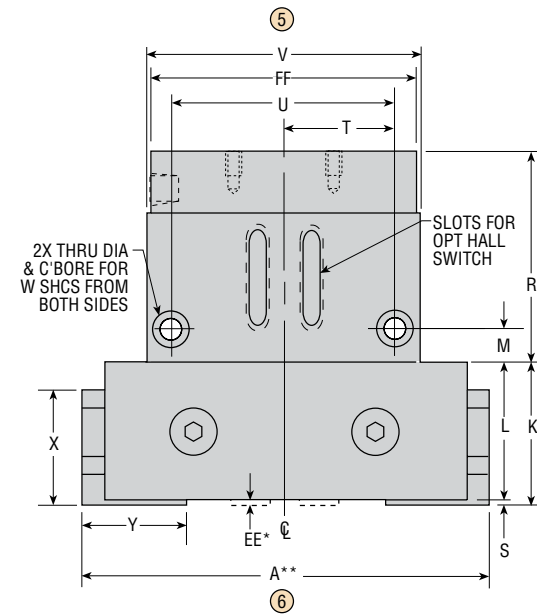
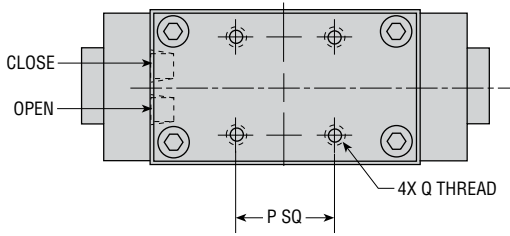

5300 par

LETTER DIM.	MODEL NUMBER							
	15360 in	15362 mm	15370 in	15372 mm	15380 in	15382 mm	15390 in	15392 mm
NOMINAL JAW TRAVEL	.62	15.8	1.00	25.4	1.31	33.3	1.80	45.8
A CLOSED**	4.16	105.6	5.71	145.0	7.22	183.4	9.98	253.5
A OPEN**	4.72	119.9	6.65	168.9	8.47	215.1	11.72	296.9
B	1.875	47.6	2.250	57.2	3.000	76.2	4.000	101.6
C	4.000	101.6	5.500	139.7	7.000	177.8	9.500	241.3
D	.960	24.4	1.130	28.7	1.440	36.6	2.190	55.6
E	.270	6.9	.420	10.7	.430	10.9	.460	11.7
F	.625	15.9	.750	19.1	1.000	25.4	1.500	38.1
G	1/4-20 x .31 DP	M6 x 1 x 8.0 DP	5/16-18 x .38 DP	M8 x 1.25 x 9.5 DP	3/8-16 x .44 DP	M10 x 1.5 x 11.0 DP	1/2-13 x .56 DP	M12 x 1.75 x 14.0 DP
H	.625	15.9	.750	19.1	1.000	25.4	1.500	38.1
K	1.604	40.7	2.161	54.9	2.827	71.8	3.811	96.8
L	1.540	39.1	2.100	53.3	2.740	69.6	3.680	93.5
M	.437	11.1	.500	12.7	.500	12.7	.500	12.7
P	1.250	31.8	1.500	38.1	1.750	44.05	2.750	69.9
Q	10-24 x .38 DP	M5 x 0.8 x 9.7 DP	1/4-20 x .38 DP	M6 x 1 x 9.7 DP	5/16-18 x .44 DP	M8 x 1.25 x 11.2 DP	3/8-16 x .56 DP	M10 x 1.5 x 14.2 DP
R	2.625	66.7	3.187	80.9	3.625	92.1	4.750	120.7
S	.062	1.6	.062	1.6	.087	2.2	.131	3.3
T	1.156	29.4	1.687	42.8	2.375	60.3	3.250	82.6
U	2.312	58.7	3.375	85.7	4.750	120.7	6.500	165.1
V	2.843	72.2	4.031	102.4	5.531	140.5	7.531	191.3
W	1/4	M6	5/16	M8	3/8	M10	1/2	M12
X	1.260	32.0	1.726	43.8	2.200	55.9	3.000	76.2
Y	1.170	29.7	1.600	40.6	1.860	47.2	2.420	61.5
Z	1.781	45.2	2.281	57.9	2.781	70.6	4.031	102.4
AA	.437	11.1	.680	17.3	.880	22.4	1.050	26.7
BB	10-32	M5 x 0.8	1/8 NPT	1/8 BSP	1/8 NPT	1/8 BSP	1/4 NPT	1/4 BSP
CC	.562	14.3	.750	19.1	.937	23.8	1.625	41.3
DD	.440	11.2	.500	12.7	.593	15.1	.760	19.3
EE	.04	1.0	0	0	.035	1.0	.05	1.0
FF	2.810	71.4	4.000	101.6	5.500	139.7	7.500	190.5
GG	1.75	44.5	2.25	57.2	2.75	69.9	3.96	100.5

- NOTES:**
- 1) NUMBERS IN [] ARE FOR METRIC UNITS AND ARE IN mm
 - 2) *EE DIMENSION IS TO BUSHING BLOCK MTG. SCREWS.
 - 3) **A CLOSED REFLECTS THE LARGEST POSSIBLE CLOSED DIMENSION. A OPEN REFLECTS THE SMALLEST POSSIBLE OPEN DIMENSION.
 - 4) CIRCLED NUMBERS INDICATE PORT POSITIONS.

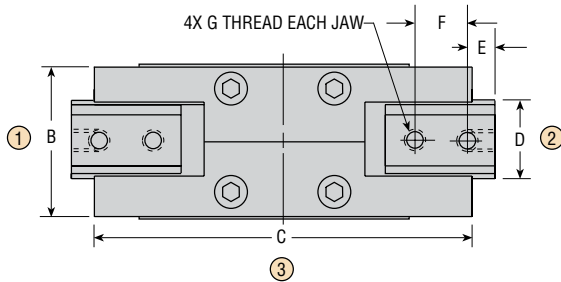

GRIPPER JAWS: SHOWN AT MID-STROKE

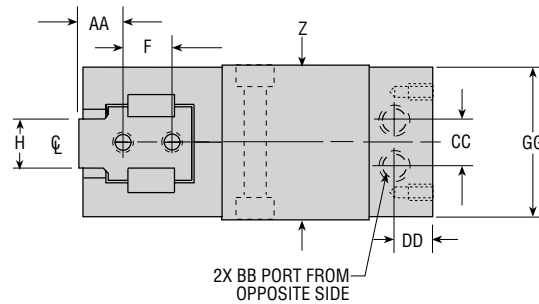

OPTION: SERIES 5300 PARALLEL OVAL GRIPPER

SERIES 5360 MINIATURE HALL EFFECT SWITCHES

PART NO.	DESCRIPTION
53603-1-02	NPN (Sink) 4.5-24 VDC, 2 meter Cable
53604-1-02	PNP (Source) 4.5-24 VDC, 2 meter Cable
53623-1	NPN (Sink) 4.5-24 VDC, Quick Connect
53624-1	PNP (Source) 4.5-24 VDC, Quick Connect

- NOTES:**
- 1) See Switches and Sensors section for switch information.
 - 2) Switches must be ordered separately.

7 HALL EFFECT MAGNET

Equips piston with magnet and "T" slot on body for Series 5360 Switches.