



GGB

**Solid
Polymer
Materials**

**The Global Leader
in High Performance
Bearing Solutions**

Technical Information

 **GGB**
BEARING TECHNOLOGY

an EnPro Industries company

Content

Forms	3
Applications	3
Solid polymer materials / Structure and features	4
EP™ - cylindrical bushes / Dimensions	5
EP™ - flanged bushes / Dimensions	6
EP22™ - cylindrical bushes / Dimensions	7
EP22™ - flanged bushes / Dimensions	8
EP43™ - cylindrical bushes / Dimensions	9
EP43™ - flanged bushes / Dimensions	10
EP63™ - cylindrical bushes / Dimensions	11
EP63™ - flanged bushes / Dimensions	12
KA™ - thrust washers / Dimensions	13
EP™ - rod stock	14
Data for bearing design calculation	15

Introduction

GGB is the leading manufacturer of polymer self-aligning bearings with over 50 years' experience in low-maintenance and maintenance-free self-aligning bearing solutions. GGB's extensive product range includes metal-polymer composite materials, filament wound materials, metal materials, bushing blocks and injection-moulded thermoplastic polymer materials.

Now the new polymer materials EP22™, EP43™ and EP63™, developed in-house by our own experts, are joining our product

portfolio, each as a standard range. These materials are based on environmental friendly polymers characterised by a low friction coefficient, high pressure resistance and low wear. The new EP materials cover a wide range of applications within the scope of the material properties. More technical details can be found in this brochure.

Subject to technical alterations and improvements in the interest of technical progress. Dimensions are specified with tolerances in accordance with ISO and GGB company standards.

The specified weights are approximate values.

Errors and omissions are expected.

EP™, EP22™, EP43™, EP63™ and KA™ are trademarks of GGB.

©2011 GGB. All rights reserved.

Standard forms

Standard forms are available as cylindrical bushes, flanged bushes, KA thrust washers, EP22 and EP43 rod stock.



Cylindrical bushes



Flanged bushes



KA thrust washers

Special forms

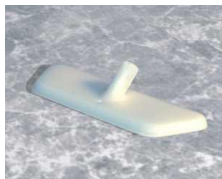

Applications

The properties of the new EP solid polymer materials allow them to be used in a wide range of applications in the automotive, aerospace, agricultural equipment, food and packaging and many more industries.

Enhanced functionality and special configurations can be provided at little additional cost. For enquiries, please contact your local GGB representative.



EP™ - Bearing Material



Cylindrical bushes and other forms

Structure

Injection moulded thermoplastic material
PA6.6T + PTFE + glass fibres + graphite

Possible Applications

Generally applicable within the limits of the material properties.

Industrial: Medical equipment, awnings and blinds, scientific equipment, gaming equipment, office equipment etc.

Features

- Injection moulded reinforced polyamide 6.6T based and modified bearing material
- Good bearing performance in the range of simple / medium working conditions
- The EP™ standard programme is interchangeable with roll-formed bushes according to ISO3547
- Recommended tolerances for fitted bushes: housing h7, shaft h7 - h9
- Colour: black

EP22™ - Bearing Material



Cylindrical bushes and other forms

Structure

Injection moulded thermoplastic dry bearing material: PBT + PTFE

Possible Applications

Generally applicable within the limits of the material properties.

Automotive: Pedal bearings, steering columns, axles
Industrial: Domestic appliances, chemical equipment, office equipment, sports equipment and many more

Features

- Injection moulded polybutylenterephthalate based and modified bearing material
- Good price/performance ratio
- Colour: white

EP43™ - Bearing Material



Cylindrical bushes and other forms

Structure

Injection moulded thermoplastic dry bearing material: PPS + PTFE + Aramid

Possible Applications

Generally applicable within the limits of the material properties.

Industrial: Domestic appliances, materials handling equipment, apparatus engineering, slot machines and cash boxes, and many more

Features

- Injection moulded reinforced polyphenylensulfide based and modified bearing material
- Good chemical and hydrolysis resistance
- Very low friction, optimised for dry running conditions
- High dimensional stability
- Colour: brown

EP63™ - Bearing Material



Cylindrical bushes and other forms

Structure

Injection moulded thermoplastic dry bearing material: PEEK + PTFE + Aramid

Possible Applications

Generally applicable within the limits of the material properties.

Industrial: Domestic appliances, valve technology, electronics assembly, agricultural machinery and many more

Features

- Injection moulded reinforced polyetheretherketone based and modified bearing material
- High temperature material with low thermal expansion for demanding components
- Optimized for dry running conditions
- High viscosity and mechanical strength
- High wear resistance in oscillating movements
- Good chemical and hydrolysis resistance
- Colour: black

KA™ - Bearing Material



Thrust washers

Structure

Polyacetal-copolymer bearing material (POM)

Possible Applications

Industrial:

Thrust washers are used as axial bearings in conjunction with all cylindrical bushes according to ISO 3547 to prevent metal to metal contact and fretting damage

Features

- Suitable for light duty applications only
- Suitable for use dry or oil grease lubrication
- Prevents metal to metal contact between assembly parts

Bearing properties	Unit	Value: EP	EP22	EP43	EP63	KA
Maximum load \bar{p}	- static - dynamic	MPa	80 -	50 -	83 -	20 10
Maximum sliding speed v	- dry	m/s	1,0	1,0	1,0	1,5*
Maximum $\bar{p}v$ factor	- for $A_H/A_C = 5$ - for $A_H/A_C = 10$ - for $A_H/A_C = 20$	MPa x m/s	0,06 0,24 1,0	0,05 0,10 0,20	0,22 0,90 3,59	0,16 0,66 2,63
Maximum temperature T_{max}		°C	+140	+170	+240	+290
Minimum temperature T_{min}		°C	-40	-50	-40	-100
Coefficient of friction f	- dry	-	0,15 - 0,30	0,22 - 0,37	0,11 - 0,20	0,12 - 0,21
Shaft surface finish Ra		µm	0,5 ± 0,3	0,3 ± 0,2	0,5 ± 0,3	0,3 ± 0,2
Shaft hardness		HV	>200	>200	>200	>200

* Values for KA with lubrication

EP™ - cylindrical bushes

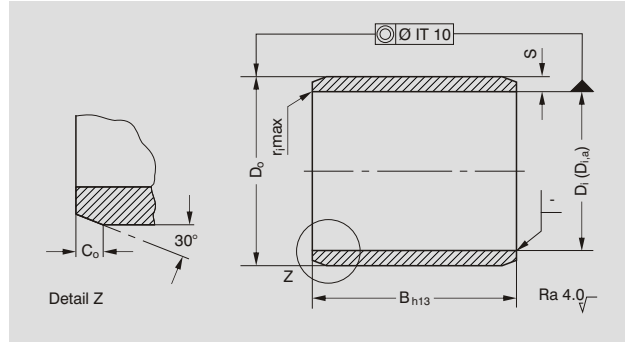

Outside chamfers and inside radiuses

S	C ₀	r _{max}
1,0	0,5	0,1
1,5	0,8	0,2
2	0,8	0,2

Recommended tolerance class for shaft h7

Dimensions [mm], tests and materials according to GGB specifications.

Part No.	Technical data					
	Dimensions				Installation tolerance	
GGB	Inner Ø D _i	Outer Ø D _o	Width B	Weight g	Housing H7	D _{i,a}
0505EP	5	7	5	0,1	+0,015 0	+0,105 +0,030
0508EP	5	7	8	0,2		
0510EP	5	7	10	0,3		
0606EP	6	8	6	0,2		
0608EP	6	8	8	0,3		
0610EP	6	8	10	0,3		
0806EP	8	10	6	0,2		
0808EP	8	10	8	0,3		
0810EP	8	10	10	0,4		
0812EP	8	10	12	0,5		
0815EP	8	10	15	0,6		
1004EP	10	12	4	0,2	+0,130 +0,040	
1006EP	10	12	6	0,3		
1008EP	10	12	8	0,4		
1010EP	10	12	10	0,5		
1015EP	10	12	15	0,7		
1020EP	10	12	20	1,0		
1210EP	12	14	10	0,6		+0,018 0
1212EP	12	14	12	0,7		
1215EP	12	14	15	0,9		
1220EP	12	14	20	1,2		
1415EP	14	16	15	1,0	+0,160 +0,050	
1420EP	14	16	20	1,4		
1425EP	14	16	25	1,7		
1515EP	15	17	15	1,1	+0,021 0	
1520EP	15	17	20	1,4		
1525EP	15	17	25	1,7		
2015EP	20	23	15	2,2	+0,025 0	+0,195 +0,065
2020EP	20	23	20	2,9		
2030EP	20	23	30	4,4		
2515EP	25	28	15	2,7	+0,025 0	
2520EP	25	28	20	3,6		
2530EP	25	28	30	5,4		
3020EP	30	34	20	5,8	+0,025 0	
3030EP	30	34	30	8,6		
3040EP	30	34	40	11,6		

D_{i,a} = Dimensions of the bush inner diameter after installation in an H7 housing.

Additional dimensions on request.

EP™ - flanged bushes

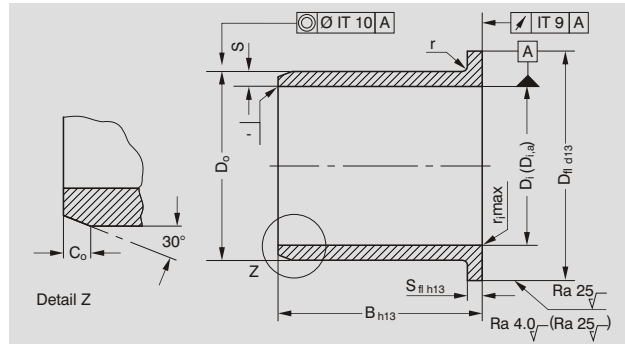

Outside chamfers and inside radiuses

S	C ₀	r _{max}
1,0	0,5	0,1
1,5	0,8	0,2

S	r (mm)
≤ 1	0,3
> 1	0,5

Recommended tolerance class for shaft h7

Dimensions [mm], tests and materials according to GGB specifications.

Part No.	Technical data							Installation tolerance	
	Dimensions						Weight g	Housing H7	D _{i,a}
GGB	Inner Ø D _i	Outer Ø D _o	Flange Ø D _{fl}	Flange S _{fl}	Width B				
BB0505EP	5	7	11	1,0	5,0	0,2	+0,015 0	+0,105 +0,030	
BB0604EP	6	8	12	1,0	4,0	0,2			
BB0606EP	6	8	12	1,0	6,0	0,3			
BB0608EP	6	8	12	1,0	8,0	0,4			
BB0610EP	6	8	12	1,0	10,0	0,4			
BB0806EP	8	10	15	1,0	5,5	0,4	+0,018 0	+0,130 +0,040	
BB0808EP	8	10	15	1,0	7,5	0,5			
BB0810EP	8	10	15	1,0	10,0	0,5			
BB1007EP	10	12	18	1,0	7,0	0,6	+0,018 0	+0,160 +0,050	
BB1009EP	10	12	18	1,0	9,0	0,7			
BB1012EP	10	12	18	1,0	12,0	0,8			
BB1015EP	10	12	18	1,0	15,0	1,0			
BB1017EP	10	12	18	1,0	17,0	1,1			
BB1207EP	12	14	20	1,0	7,0	0,6	+0,021 0	+0,195 +0,065	
BB1209EP	12	14	20	1,0	9,0	0,8			
BB1212EP	12	14	20	1,0	12,0	1,2			
BB1215EP	12	14	20	1,0	15,0	1,3			
BB1217EP	12	14	20	1,0	17,0	1,4			
BB1220EP	12	14	20	1,0	20,0	1,5			
BB1412EP	14	16	22	1,0	12,0	0,9			
BB1417EP	14	16	22	1,0	17,0	1,5			
BB1509EP	15	17	23	1,0	9,0	1,0	+0,021 0	+0,195 +0,065	
BB1512EP	15	17	23	1,0	12,0	1,2			
BB1517EP	15	17	23	1,0	17,0	1,5			
BB1520EP	15	17	23	1,0	20,0	1,8			
BB1617EP	16	18	24	1,0	17,0	1,7			
BB2012EP	20	23	30	1,5	11,5	2,4	+0,021 0	+0,195 +0,065	
BB2017EP	20	23	30	1,5	16,5	3,2			
BB2022EP	20	23	30	1,5	21,5	3,9			
BB2512EP	25	28	35	1,5	11,5	2,9			
BB2517EP	25	28	35	1,5	16,5	3,9			
BB2522EP	25	28	35	1,5	21,5	4,9			

D_{i,a} = Dimensions of the bush inner diameter after installation in an H7 housing.

Additional dimensions on request.

EP22™ - cylindrical bushes

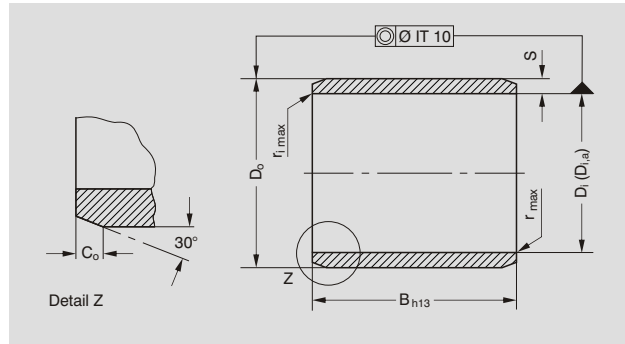
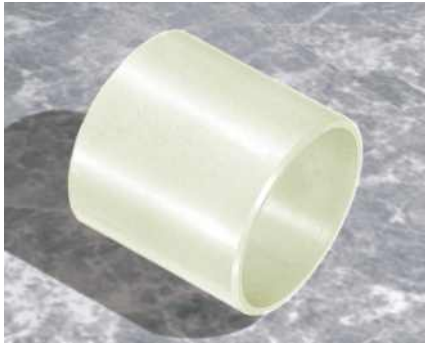

Outside chamfers and inside radiuses

S	C _o	r _{max}
1,0	0,5	0,2
1,5	0,8	0,3
2	0,8	0,3

Recommended tolerance class for shaft h9

Dimensions [mm], tests and materials according to GGB specifications.

Part No.	Technical data					
	Dimensions			Weight g	Installation tolerance	
GGB	Inner Ø D _i	Outer Ø D _o	Width B		Housing H7	D _{i,a}
0806EP22	8	10	6	0,2	+0,015 0	+0,083 +0,025
0808EP22	8	10	8	0,3		
0810EP22	8	10	10	0,4		
0812EP22	8	10	12	0,5		
0815EP22	8	10	15	0,6		
1004EP22	10	12	4	0,2	+0,018 0	+0,102 +0,032
1006EP22	10	12	6	0,3		
1008EP22	10	12	8	0,4		
1010EP22	10	12	10	0,5		
1015EP22	10	12	15	0,7		
1020EP22	10	12	20	1,0		
1210EP22	12	14	10	0,6		
1212EP22	12	14	12	0,7		
1215EP22	12	14	15	0,9		
1220EP22	12	14	20	1,2		
1415EP22	14	16	15	1,0	+0,021 0	+0,124 +0,040
1420EP22	14	16	20	1,4		
1425EP22	14	16	25	1,7		
1515EP22	15	17	15	1,1	+0,021 0	+0,124 +0,040
1520EP22	15	17	20	1,4		
1525EP22	15	17	25	1,7		
2015EP22	20	23	15	2,2	+0,021 0	+0,124 +0,040
2020EP22	20	23	20	2,9		
2030EP22	20	23	30	4,4		
2515EP22	25	28	15	2,7	+0,021 0	+0,124 +0,040
2520EP22	25	28	20	3,6		

D_{i,a} = Dimensions of the bush inner diameter after installation in an H7 housing.

Additional dimensions on request.

EP22™ - flanged bushes

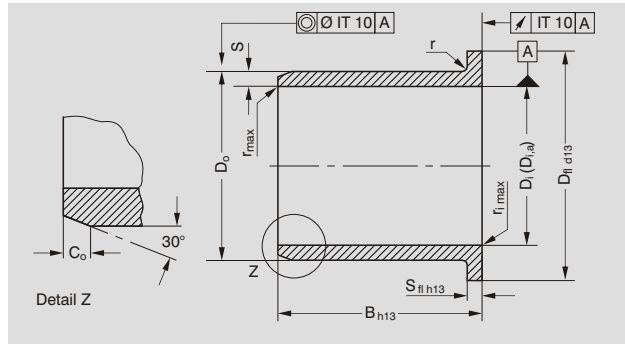

Outside chamfers and inside radiuses

S	C _o	r _{max}
1,0	0,5	0,2
1,5	0,8	0,3

S	r (mm)
≤ 1	0,3
> 1	0,5

Recommended tolerance class for shaft h9

Dimensions [mm], tests and materials according to GGB specifications.

Part No.	Technical data						Installation tolerance	
	Dimensions						Housing H7	D _{i,a}
GGB	Inner Ø D _i	Outer Ø D _o	Flange Ø D _{fl}	Flange S _{fl}	Width B	Weight g		
BB0806EP22	8	10	15	1,0	5,5	0,4	+0,015 0	
BB0808EP22	8	10	15	1,0	7,5	0,5		
BB0810EP22	8	10	15	1,0	10	0,5		
BB1007EP22	10	12	18	1,0	7	0,6	+0,018 0	+0,083 +0,025
BB1009EP22	10	12	18	1,0	9	0,7		
BB1012EP22	10	12	18	1,0	12	0,8		
BB1015EP22	10	12	18	1,0	15	1,0		
BB1017EP22	10	12	18	1,0	17	1,1		
BB1207EP22	12	14	20	1,0	7	0,6		
BB1209EP22	12	14	20	1,0	9	0,8	+0,102 +0,032	
BB1212EP22	12	14	20	1,0	12	1,2		
BB1215EP22	12	14	20	1,0	15	1,3		
BB1217EP22	12	14	20	1,0	17	1,4		
BB1220EP22	12	14	20	1,0	20	1,5		
BB1412EP22	14	16	22	1,0	12	0,9		
BB1417EP22	14	16	22	1,0	17	1,5	+0,021 0	+0,124 +0,040
BB1509EP22	15	17	23	1,0	9	1,0		
BB1512EP22	15	17	23	1,0	12	1,2		
BB1517EP22	15	17	23	1,0	17	1,5		
BB1520EP22	15	17	23	1,0	20	1,8		
BB1617EP22	16	18	24	1,0	17	1,7		
BB2012EP22	20	23	30	1,5	11,5	2,4	+0,021 0	+0,124 +0,040
BB2017EP22	20	23	30	1,5	16,5	3,2		
BB2022EP22	20	23	30	1,5	21,5	3,9		
BB2512EP22	25	28	35	1,5	11,5	2,9	+0,021 0	+0,124 +0,040
BB2517EP22	25	28	35	1,5	16,5	3,9		
BB2522EP22	25	28	35	1,5	21,5	4,9		

D_{i,a} = Dimensions of the bush inner diameter after installation in an H7 housing.

Additional dimensions on request.

EP43™ - cylindrical bushes

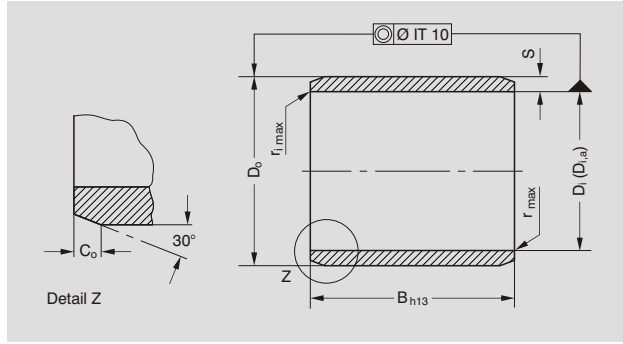

Outside chamfers and inside radiuses

S	C _o	r _{max}
1,0	0,5	0,2
1,5	0,8	0,3
2	0,8	0,3

Recommended tolerance class for shaft h9

Dimensions [mm], tests and materials according to GGB specifications.

Part No.	Technical data					
	Dimensions				Installation tolerance	
GGB	Inner Ø D _i	Outer Ø D _o	Width B	Weight g	Housing H7	D _{i,a}
0806EP43	8	10	6	0,2	+0,015 0	+0,071 +0,013
0808EP43	8	10	8	0,3		
0810EP43	8	10	10	0,4		
0812EP43	8	10	12	0,5		
0815EP43	8	10	15	0,6		
1004EP43	10	12	4	0,2	+0,018 0	+0,086 +0,016
1006EP43	10	12	6	0,3		
1008EP43	10	12	8	0,4		
1010EP43	10	12	10	0,5		
1015EP43	10	12	15	0,7		
1020EP43	10	12	20	1,0		
1210EP43	12	14	10	0,6		
1212EP43	12	14	12	0,7		
1215EP43	12	14	15	0,9		
1220EP43	12	14	20	1,2		
1415EP43	14	16	15	1,0	+0,021 0	+0,104 +0,020
1420EP43	14	16	20	1,4		
1425EP43	14	16	25	1,7		
1515EP43	15	17	15	1,1	+0,021 0	+0,104 +0,020
1520EP43	15	17	20	1,4		
1525EP43	15	17	25	1,7		
2015EP43	20	23	15	2,2	+0,021 0	+0,104 +0,020
2020EP43	20	23	20	2,9		
2030EP43	20	23	30	4,4		
2515EP43	25	28	15	2,7	+0,021 0	+0,104 +0,020
2520EP43	25	28	20	3,6		

D_{i,a} = Dimensions of the bush inner diameter after installation in an H7 housing.

Additional dimensions on request.

EP43™ - flanged bushes

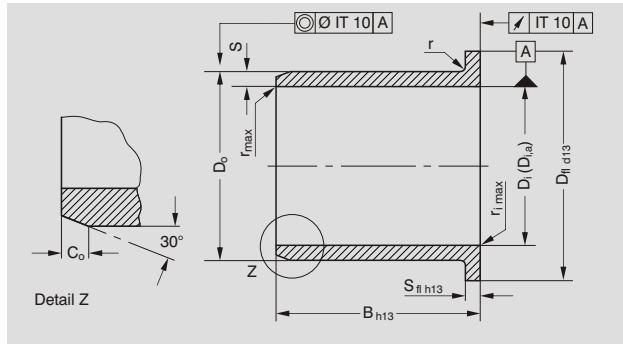

Outside chamfers and inside radiuses

S	C ₀	r _{max}
1,0	0,5	0,2
1,5	0,8	0,3

S	r (mm)
≤ 1	0,3
> 1	0,5

Recommended tolerance class for shaft h9

Dimensions [mm], tests and materials according to GGB specifications.

Part No.	Technical data							Installation tolerance	
	Dimensions						Weight g	Housing H7	D _{i,a}
GGB	Inner Ø D _i	Outer Ø D _o	Flange Ø D _{fl}	Flange S _{fl}	Width B				
BB0806EP43	8	10	15	1,0	5,5	0,4	+0,015 0	+0,071 +0,013	
BB0808EP43	8	10	15	1,0	7,5	0,5			
BB0810EP43	8	10	15	1,0	10	0,5			
BB1007EP43	10	12	18	1,0	7	0,6	+0,018 0	+0,086 +0,016	
BB1009EP43	10	12	18	1,0	9	0,7			
BB1012EP43	10	12	18	1,0	12	0,8			
BB1015EP43	10	12	18	1,0	15	1,0			
BB1017EP43	10	12	18	1,0	17	1,1			
BB1207EP43	12	14	20	1,0	7	0,6			
BB1209EP43	12	14	20	1,0	9	0,8	+0,021 0	+0,104 +0,020	
BB1212EP43	12	14	20	1,0	12	1,2			
BB1215EP43	12	14	20	1,0	15	1,3			
BB1217EP43	12	14	20	1,0	17	1,4			
BB1220EP43	12	14	20	1,0	20	1,5			
BB1412EP43	14	16	22	1,0	12	0,9			
BB1417EP43	14	16	22	1,0	17	1,5	+0,021 0	+0,104 +0,020	
BB1509EP43	15	17	23	1,0	9	1,0			
BB1512EP43	15	17	23	1,0	12	1,2			
BB1517EP43	15	17	23	1,0	17	1,5			
BB1520EP43	15	17	23	1,0	20	1,8			
BB1617EP43	16	18	24	1,0	17	1,7	+0,021 0	+0,104 +0,020	
BB2012EP43	20	23	30	1,5	11,5	2,4			
BB2017EP43	20	23	30	1,5	16,5	3,2			
BB2022EP43	20	23	30	1,5	21,5	3,9	+0,021 0	+0,104 +0,020	
BB2512EP43	25	28	35	1,5	11,5	2,9			
BB2517EP43	25	28	35	1,5	16,5	3,9			
BB2522EP43	25	28	35	1,5	21,5	4,9			

D_{i,a} = Dimensions of the bush inner diameter after installation in an H7 housing.

Additional dimensions on request.

EP63™ - cylindrical bushes

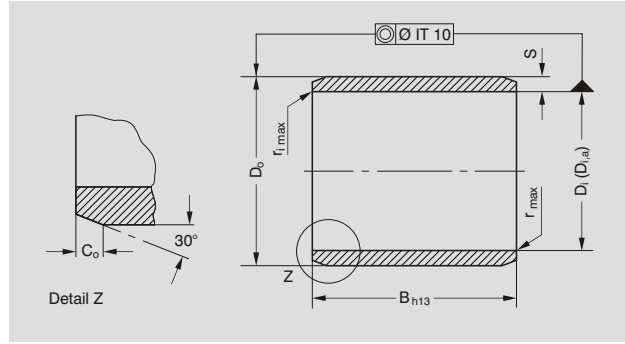

Outside chamfers and inside radiuses

S	C _o	r _{max}
1,0	0,5	0,2
1,5	0,8	0,3
2	0,8	0,3

Recommended tolerance class for shaft h9

Dimensions [mm], tests and materials according to GGB specifications.

Part No.	Technical data					
	Dimensions				Installation tolerance	
GGB	Inner Ø D _i	Outer Ø D _o	Width B	Weight g	Housing H7	D _{i,a}
0806EP63	8	10	6	0,2	+0,015 0	+0,071 +0,013
0808EP63	8	10	8	0,3		
0810EP63	8	10	10	0,4		
0812EP63	8	10	12	0,5		
0815EP63	8	10	15	0,6		
1004EP63	10	12	4	0,2	+0,018 0	+0,086 +0,016
1006EP63	10	12	6	0,3		
1008EP63	10	12	8	0,4		
1010EP63	10	12	10	0,5		
1015EP63	10	12	15	0,7		
1020EP63	10	12	20	1,0		
1210EP63	12	14	10	0,6		
1212EP63	12	14	12	0,7		
1215EP63	12	14	15	0,9		
1220EP63	12	14	20	1,2		
1415EP63	14	16	15	1,0	+0,021 0	+0,104 +0,020
1420EP63	14	16	20	1,4		
1425EP63	14	16	25	1,7		
1515EP63	15	17	15	1,1	+0,021 0	+0,104 +0,020
1520EP63	15	17	20	1,4		
1525EP63	15	17	25	1,7		
2015EP63	20	23	15	2,2	+0,021 0	+0,104 +0,020
2020EP63	20	23	20	2,9		
2030EP63	20	23	30	4,4		
2515EP63	25	28	15	2,7		
2520EP63	25	28	20	3,6		

D_{i,a} = Dimensions of the bush inner diameter after installation in an H7 housing.

Additional dimensions on request.

EP63™ - flanged bushes

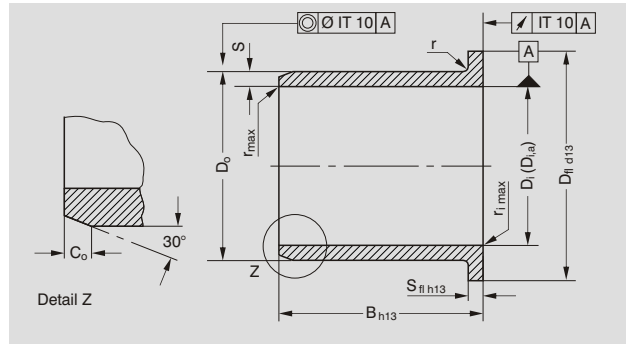

Outside chamfers and inside radiuses

S	C ₀	r _{max}
1,0	0,5	0,2
1,5	0,8	0,3

S	r (mm)
≤ 1	0,3
> 1	0,5

Recommended tolerance class for shaft h9

Dimensions [mm], tests and materials according to GGB specifications.

Part No.	Technical data							Installation tolerance	
	Dimensions						Weight g	Housing H7	D _{i,a}
GGB	Inner Ø D _i	Outer Ø D _o	Flange Ø D _{fl}	Flange S _{fl}	Width B				
BB0806EP63	8	10	15	1,0	5,5	0,4	+0,015 0	+0,071 +0,013	
BB0808EP63	8	10	15	1,0	7,5	0,5			
BB0810EP63	8	10	15	1,0	10	0,5			
BB1007EP63	10	12	18	1,0	7	0,6	+0,018 0	+0,086 +0,016	
BB1009EP63	10	12	18	1,0	9	0,7			
BB1012EP63	10	12	18	1,0	12	0,8			
BB1015EP63	10	12	18	1,0	15	1,0			
BB1017EP63	10	12	18	1,0	17	1,1			
BB1207EP63	12	14	20	1,0	7	0,6			
BB1209EP63	12	14	20	1,0	9	0,8	+0,021 0	+0,104 +0,020	
BB1212EP63	12	14	20	1,0	12	1,2			
BB1215EP63	12	14	20	1,0	15	1,3			
BB1217EP63	12	14	20	1,0	17	1,4			
BB1220EP63	12	14	20	1,0	20	1,5			
BB1412EP63	14	16	22	1,0	12	0,9			
BB1417EP63	14	16	22	1,0	17	1,5	+0,021 0	+0,104 +0,020	
BB1509EP63	15	17	23	1,0	9	1,0			
BB1512EP63	15	17	23	1,0	12	1,2			
BB1517EP63	15	17	23	1,0	17	1,5			
BB1520EP63	15	17	23	1,0	20	1,8			
BB1617EP63	16	18	24	1,0	17	1,7	+0,021 0	+0,104 +0,020	
BB2012EP63	20	23	30	1,5	11,5	2,4			
BB2017EP63	20	23	30	1,5	16,5	3,2			
BB2022EP63	20	23	30	1,5	21,5	3,9	+0,021 0	+0,104 +0,020	
BB2512EP63	25	28	35	1,5	11,5	2,9			
BB2517EP63	25	28	35	1,5	16,5	3,9			
BB2522EP63	25	28	35	1,5	21,5	4,9			

D_{i,a} = Dimensions of the bush inner diameter after installation in an H7 housing.

Additional dimensions on request.

Glacetal KA™ - thrust washers

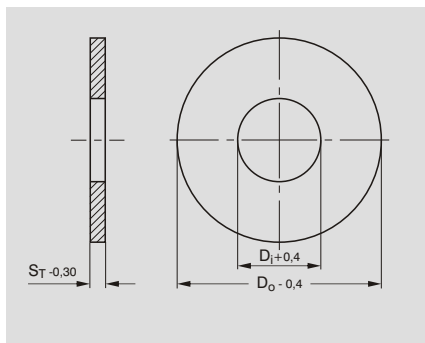
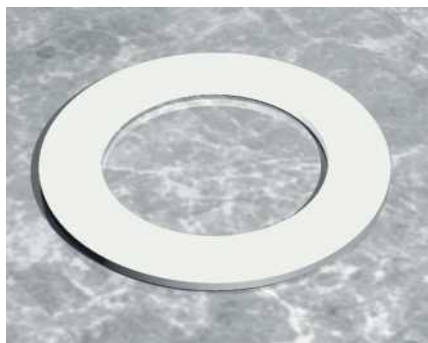

Part No.	Technical data			
	Dimensions			Weight g
GGB	Inner Ø D _i	Outer Ø D _o	Thickness S _T	
WC10KA	10,5	24,20	1,65	0,8
WC12KA	12,5	26,20	1,65	0,9
WC14KA	14,5	30,20	1,65	1,1
WC16KA	16,5	32,20	1,65	1,3
WC18KA	18,5	36,20	1,65	1,6
WC20KA	20,5	38,20	1,65	1,7
WC22KA	22,5	42,20	1,65	2,0
WC24KA	24,5	44,20	1,65	2,2
WC25KA	25,5	48,20	1,65	2,8
WC28KA	28,5	48,20	1,65	2,5
WC30KA	30,5	54,20	1,65	3,3
WC35KA	36,0	62,20	1,65	4,3
WC40KA	41,0	66,20	1,65	4,7
WC45KA	46,0	74,20	2,15	5,6
WC50KA	51,0	78,20	2,15	5,8

Additional dimensions on request.

EP™ - rod stock

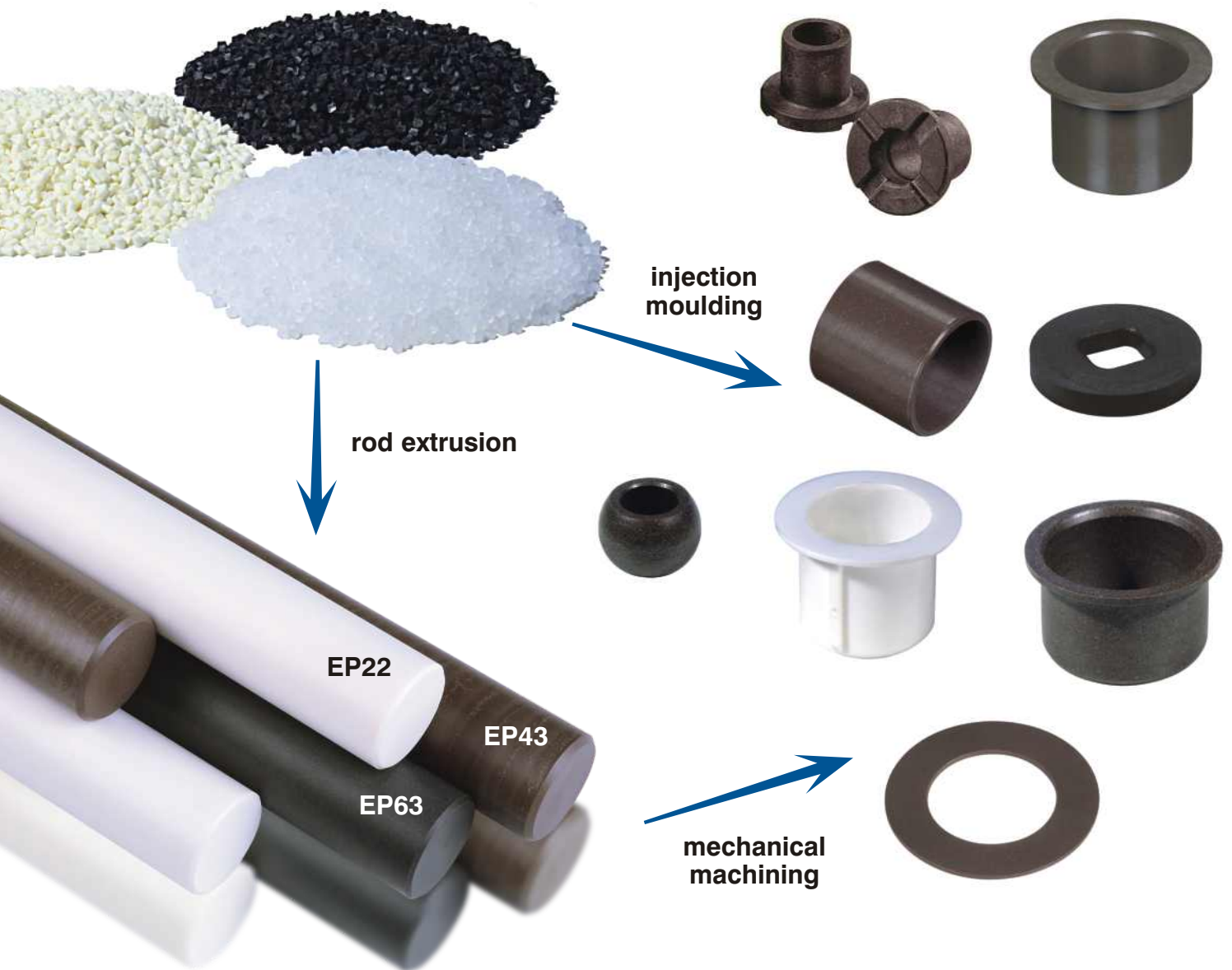

Requirement

- Edge load
- Acids / alkalis
- Abrasive
- Corrosive
- Alignment error
- Double layer
- Complex geometries
- And tribological suitability?

This specification sheet can be extended almost arbitrarily and met thanks to engineering plastics. Although, materials belonging to the EP series must be clearly separated from those which would usually be known as plastics in private life. The materials of the EP series have been

developed in such a way that all current technical requirements can be met. They are tribologically modified so that they are not only used in cases where the price is the most important technical criterion, but can, if suitably selected, also act as real problem solvers. For this purpose, all materials in the EP series are tribologically described in order to allow for a service life assessment on announcement of the service conditions.

The idea of providing the customer with the same material from the very first prototypes right up to the series has for the first time been realised by

GBB in the concept of "rapid prototyping" in the area of plain bearings.

Thus, functional models in the EP series can be manufactured and made available for tests within a short period of time in the company's own prototype centre. In a further step towards the series, die-cut parts can be manufactured by injection moulding by means of our master mould concept or GGB offers semi-finished parts belonging to the EP series for mechanically manufactured bearings for small batches. The processing guidelines on this are available on request.

Data for bearing design calculation

Application: _____

Project / No.: _____

Quantity: _____ New Design Existing Design

Dimensions [mm]	
Inside diameter	D_i
Outside diameter	D_o
Length	B
Outer ring length	B_F
Flange diameter	D_{fl}
Flange thickness	B_{fl}
Wall thickness	S_T
Length of slideplate	L
Width of slideplate	W
Thickness of slideplate	S_S

Load	
<input type="checkbox"/> Radial load F	
- static	[N]
- dynamic	[N]
<input type="checkbox"/> Axial load F	
- static	[N]
- dynamic	[N]
<input type="checkbox"/> Specific load \bar{p}	
- radial	[MPa]
- axial	[MPa]

Movement	
Rotational speed	N [1/min]
Speed	v [ms]
Length of stroke	L_S [mm]
Frequency of stroke	[1/min]
Oscillating cycle	φ [°]
Oscillating freq.	N_{OSZ} [1/min]

Mating Surface	
Material	
Hardness	HB/HRC
Surface finish	Ra [μ m]

Fits and Tolerances	
Shaft	D_J
Bearing housing	D_H

Operating Environment	
Ambient temperature T_{amb} [°]	
<input type="checkbox"/>	Housing with good heating transfer properties
<input type="checkbox"/>	Light pressing or insulated housing with poor heat transfer properties
<input type="checkbox"/>	Non metal housing with poor heat transfer properties
<input type="checkbox"/>	Alternate operation in water and dry

Lubrication	
<input type="checkbox"/>	Dry
<input type="checkbox"/>	Continuous lubrication
<input type="checkbox"/>	Process fluid lubrication
<input type="checkbox"/>	Initial lubrication only
<input type="checkbox"/>	Hydrodynamic conditions
Process fluid	
Lubricant	
Dynamic viscosity	η

Service Hours per Day	
<input type="checkbox"/>	Continuous operation
<input type="checkbox"/>	Intermittent operation
<input type="checkbox"/>	Operating time
<input type="checkbox"/>	Days per year

Service Life	
Required service life	L_H [h]

Customer Information	
Company _____	
Street _____	
City / Post Code _____	
Name _____	
Tel. _____	Fax _____
Date / Signature _____	

Bearing Type:

Cylindrical bushing

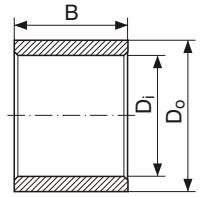

Flanged bushing

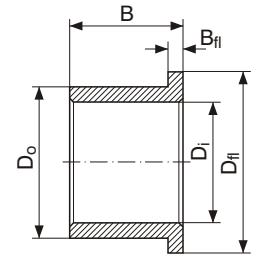

Thrust washer

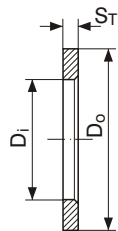

Spherical bearing

Steady load
 Rotating load

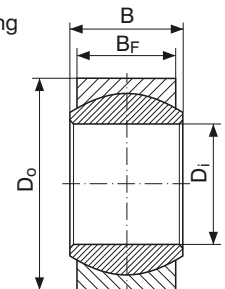

Slideplate

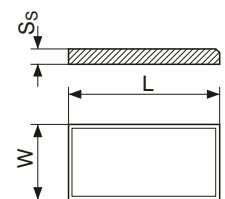

Special parts (sketch)

- Rotational movement
- Steady load
- Rotating load
- Oscillating movement
- Linear movement

Product Information

GGB gives an assurance that the products described in this document have no manufacturing errors or material deficiencies. The details set out in this document are registered to assist in assessing the material's suitability for the intended use. They have been developed from our own investigations as well as from generally accessible publications. They do not represent any assurance for the properties themselves.

Unless expressly declared in writing, GGB gives no warranty that the products described are suited to any particular purpose or specific operating circumstances. GGB accepts no liability for any losses, damages or costs however they may arise through direct or indirect use of these products.

GGB's sales and delivery terms and conditions, included as an integral part of quotations, stock and price lists, apply absolutely to all business conducted by GGB. Copies can be made available on request.

Products are subject to continual development. GGB retains the right to make specification amendments or improvements to the technical data without prior announcement.

Edition 2011 (This edition replaces earlier editions which hereby lose their validity).

Declaration on lead contents of GGB products/compliance with EU law

Since July 1, 2006 it has been prohibited under Directive 2002/95/EC (restriction of the use of certain hazardous substances in electrical and electronic equipment; ROHS Directive) to put products on the market that contain lead, mercury, cadmium, hexavalent chromium, polybrominated biphenyls (PBB) or polybrominated diphenyl ethers (PBDE). Certain applications listed in the annex to the ROHS Directive are exempted. A maximum concentration value of 0.01% by weight and per homogeneous material, for cadmium and of 0.1% by weight and per homogeneous material, for lead, mercury, hexavalent chromium, PBB and PBDE shall be tolerated.

According to Directive 2000/53/EC on end-of-life vehicles, since July 1, 2003 it has been prohibited to put on the market materials and components that contain lead, mercury, cadmium or

hexavalent chromium. Due to an exceptional provision, lead-containing bearing shells and bushes could still be put on the market up until July 1, 2008. This general exception expired on July 1, 2008. A maximum concentration value of up to 0.1% by weight and per homogeneous material, for lead, hexavalent chromium and mercury shall be tolerated.

All products of GGB in this brochure, with the exception of DU, DUB, DB, SY and SP, satisfy these requirements of Directives 2002/95/EC (ROHS Directive) and 2000/53/EC (End-of-life Vehicle Directive).

All products manufactured by GGB are also compliant with REACH Regulation (EC) No. 1907/2006 of December 18, 2006.